

THIS DRAWING IS INTENDED TO BE PRINTED IN COLOR.

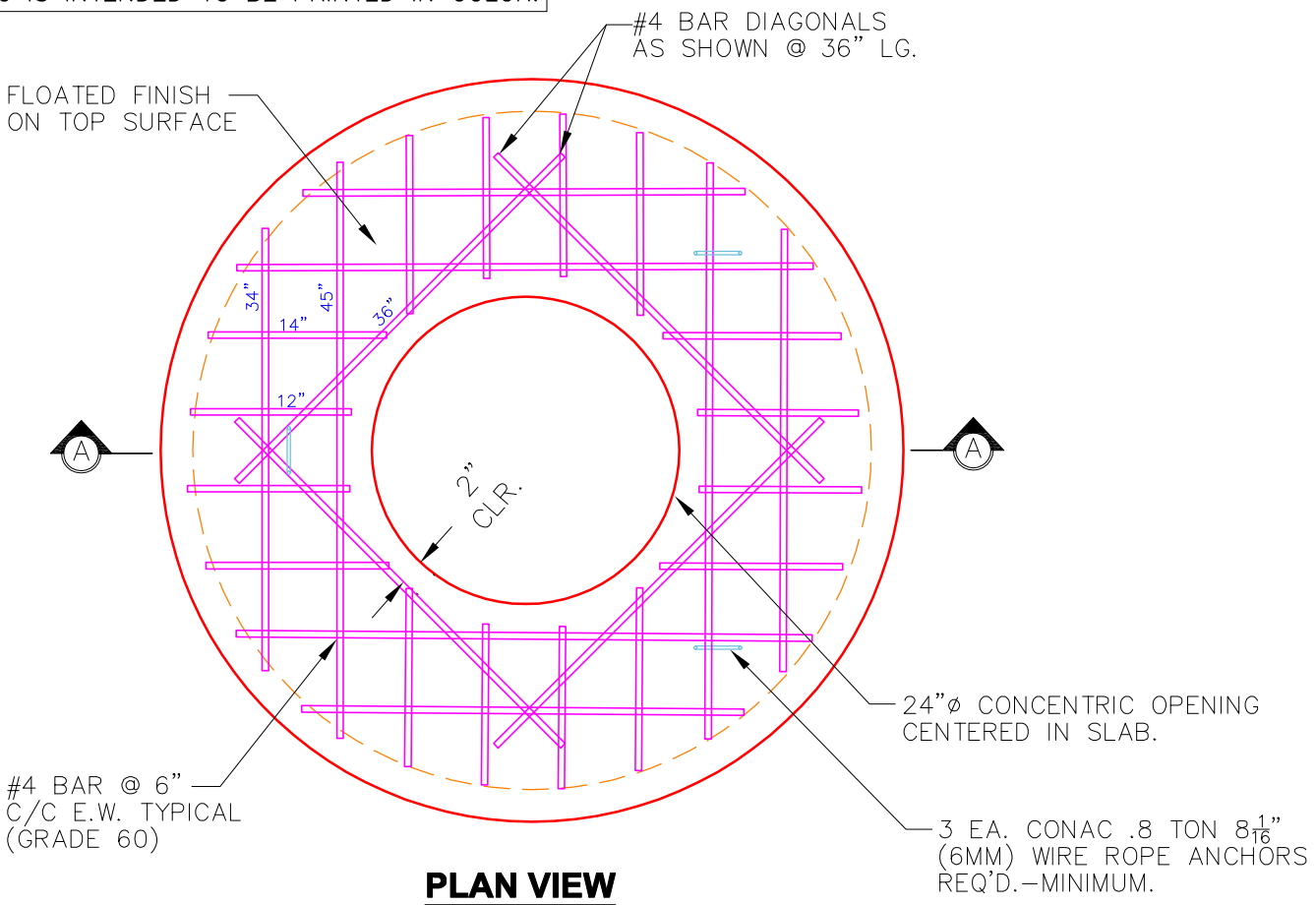

**PLAN VIEW**

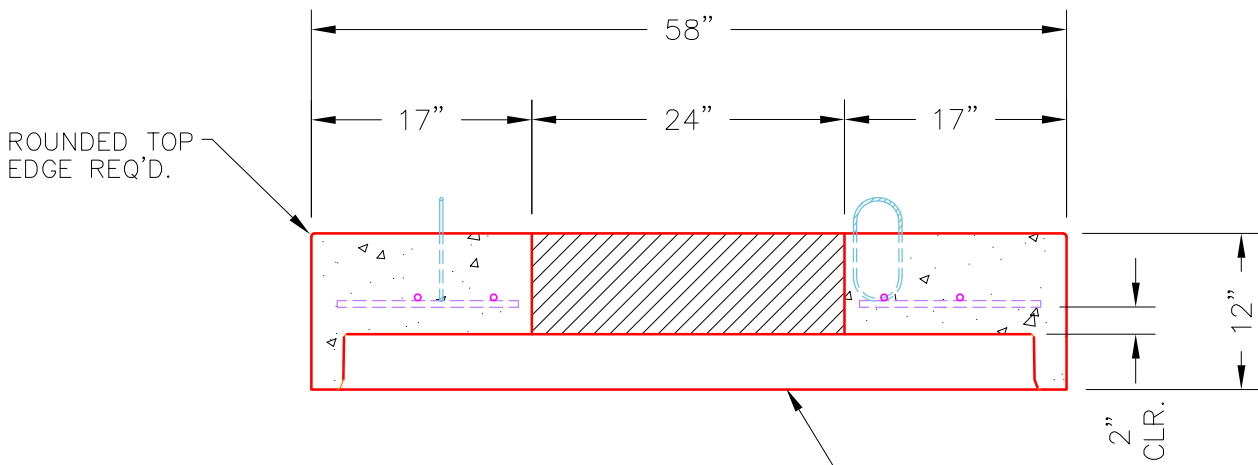

**SECTION A-A**

**NOTES:**

1. MANUFACTURED TO ASTM C-478 (LATEST REVISION).
2. CONCRETE: 5,000 PSI AT 28 DAYS.
3. REINFORCING: #4 BAR AS SHOWN (GRADE 60).
4. WEIGHT: 1,340 LBS.

**#4 BAR CUT LIST**

- 4 EA. @ 45"
- 4 EA. @ 36"
- 4 EA. @ 34"
- 8 EA. @ 14"
- 8 EA. @ 12"

<p>PRODUCTION WORK ORDER</p>		<p>PRODUCT I.D.: MH048LD12</p>	<p>DESCRIPTION: 48"Ø X 12" MANHOLE TOP SLAB W/24"Ø CON.</p>
	<p>QUALITY CONTROL CHECKLIST</p>		<p>CUSTOMER: STOCK</p>
	<input type="checkbox"/> ALL DIMENSIONS CORRECT.		<p>PROJECT: STOCK</p>
	<input type="checkbox"/> WIRE LIFT LOOPS INSTALLED.		<p>STRUCTURE I.D.: STOCK</p>
	<input type="checkbox"/> HOLE LOCATION CORRECT.		<p>QUOTE/SALES ORDER NO: STOCK</p>
	<input type="checkbox"/> REINFORCING CORRECT.		<p>PC: J.H. ROSS, PE</p>
	<input type="checkbox"/> FLOATED FINISH ON SLAB ACCEPTABLE.		<p>DRAWING: N. RICHARDS</p>
	<input type="checkbox"/> GROOVE JOINT INSTALLED.		<p>DATE: 03/22/21</p>
<p>PRODUCT VIEW: RIGHT SIDE UP</p>		<p>SCALE: NTS</p>	<p>PG. 1 of 1</p>
<p>PLANT: BEAVER DAM, KY.</p>			
<p>WEIGHT: 1,340 LBS.</p>			
<p>TOP JOINT: N/A</p>			
<p>BOTTOM JOINT: GROOVE</p>			
<p>QC CHECK INITIALS:</p>			