

THIS DRAWING IS INTENDED TO BE PRINTED IN COLOR.

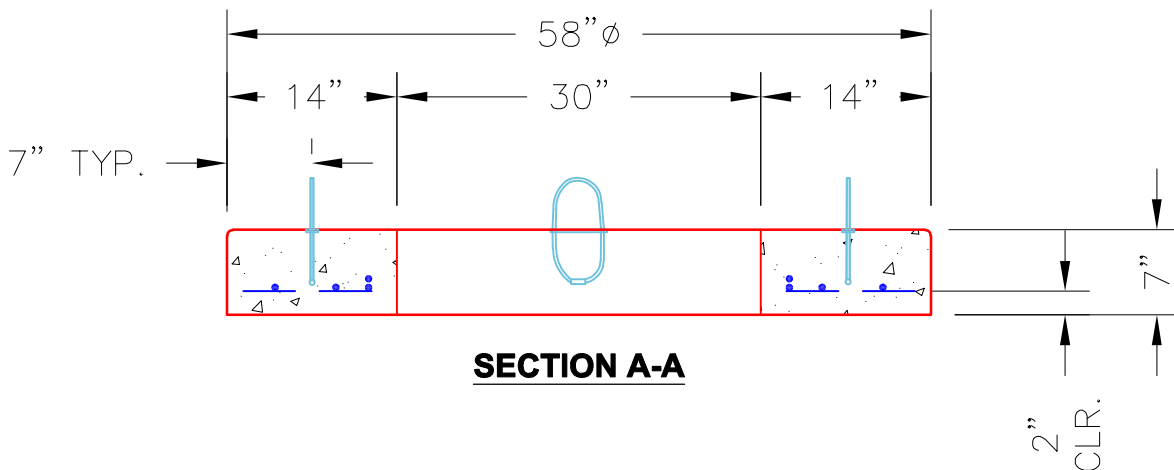
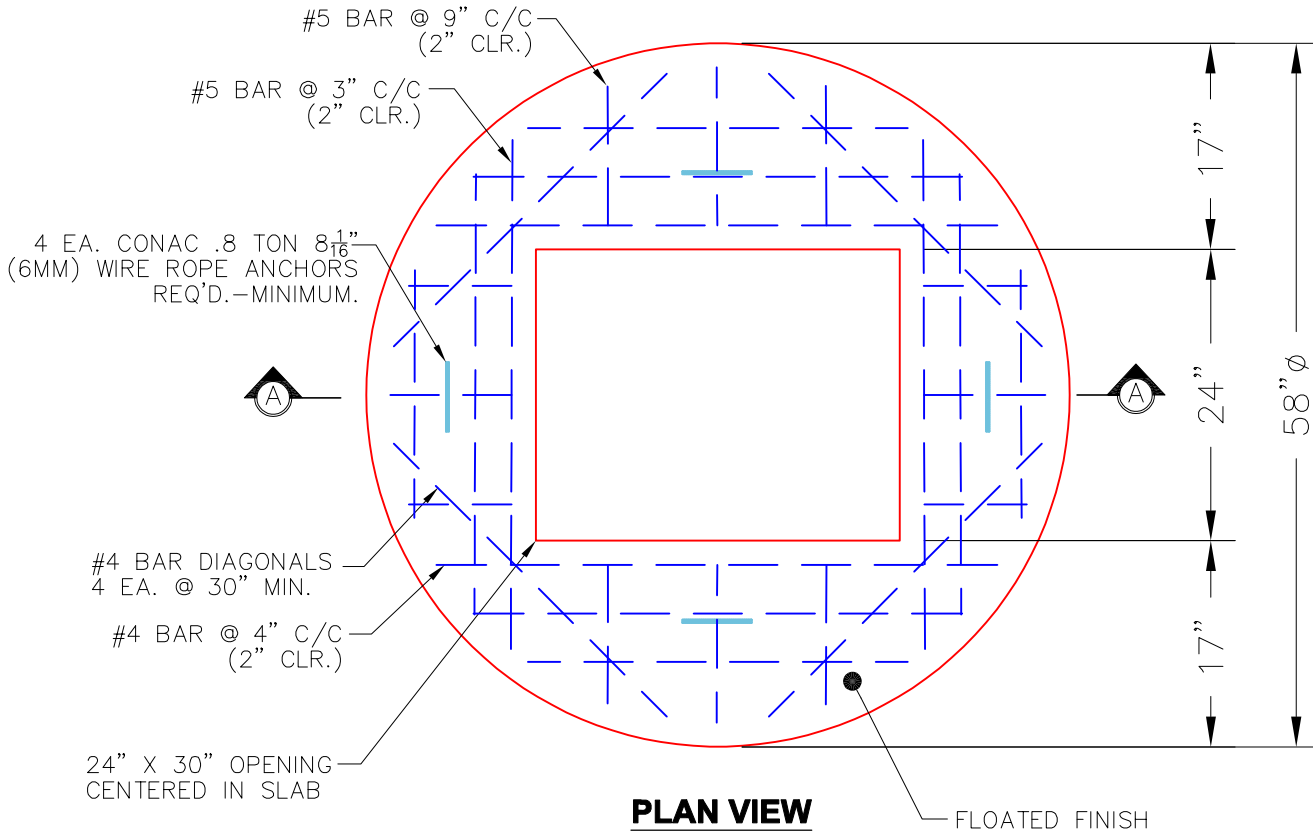

NOTES:

1. MANUFACTURED TO ASTM C-478 (LATEST REVISION).
2. CONCRETE: 4,500 PSI AT 28 DAYS.
3. REINFORCING: #5 & #4 BAR AS SHOWN (GRADE 60).
4. 4 EA. CONAC .8 TON WIRE ROPE ANCHORS FOR HANDLING.

#4 BAR CUT LIST #5 BAR CUT LIST

4 EA. @ 46"	2 EA. @ 42"
4 EA. @ 40"	2 EA. @ 36"
8 EA. @ 30"	2 EA. @ 20"
	4 EA. @ 13"
	8 EA. @ 12"

PRODUCTION WORK ORDER		PRODUCT I.D.:	DESCRIPTION:
		MH048LD07-24X30RECT	48" ϕ X 7" MANHOLE TOP SLAB W/24"X30"
 <p>QUALITY CONTROL CHECKLIST</p> <p><input type="checkbox"/> ALL DIMENSIONS CORRECT.</p> <p><input type="checkbox"/> WIRE LIFT LOOPS INSTALLED.</p> <p><input type="checkbox"/> HOLE LOCATION CORRECT.</p> <p><input type="checkbox"/> REINFORCING CORRECT.</p> <p><input type="checkbox"/> FINISH ON SLAB SURFACE UNIFORM.</p> <p><input type="checkbox"/> OUTSIDE TOP EDGE TROWELLED.</p> <p><input type="checkbox"/> FLAT BOTTOM INSTALLED.</p>	PRODUCT VIEW: RIGHT SIDE UP	CUSTOMER: STOCK	
	PLANT: BEAVER DAM, KY.	PROJECT: STOCK	
	WEIGHT: 1,045 LBS.	STRUCTURE ID.: N/A	
	TOP JOINT: N/A	SALES ORDER NO.: 23-2417	
	BOTTOM JOINT: FLAT	P.E.: J. ROSS	DRAWING: J. COPPAGE
	QC CHECK INITIALS:	DATE: 7/15/24	SCALE: NTS
			PG. 1 of 1