

DIMENSIONS										
PIPE ϕ	A	B	C	D	E	F	G	H	I	WEIGHT
15"	2'-9"	3'-6"	2'-0"	1'-6"	4'-0"	3"	28"	2'-0"	4'-9"	3,161 LBS.

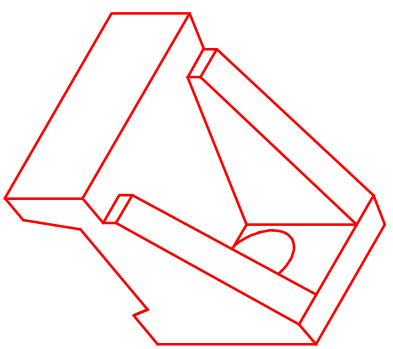

ISOMETRIC VIEW
15" ϕ HEADWALL

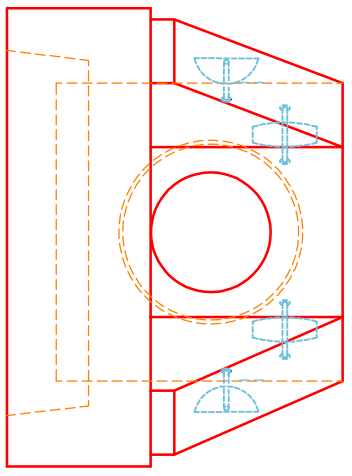
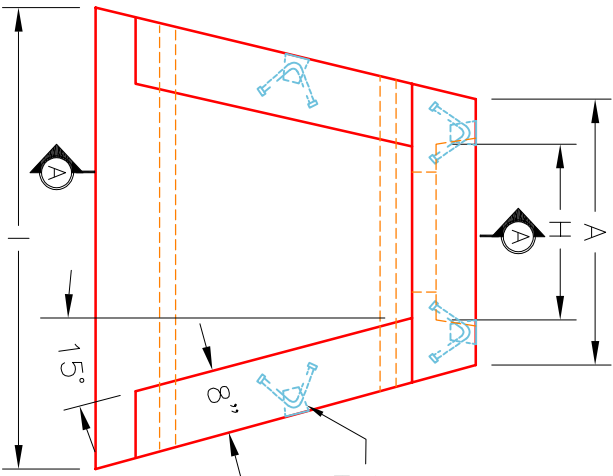
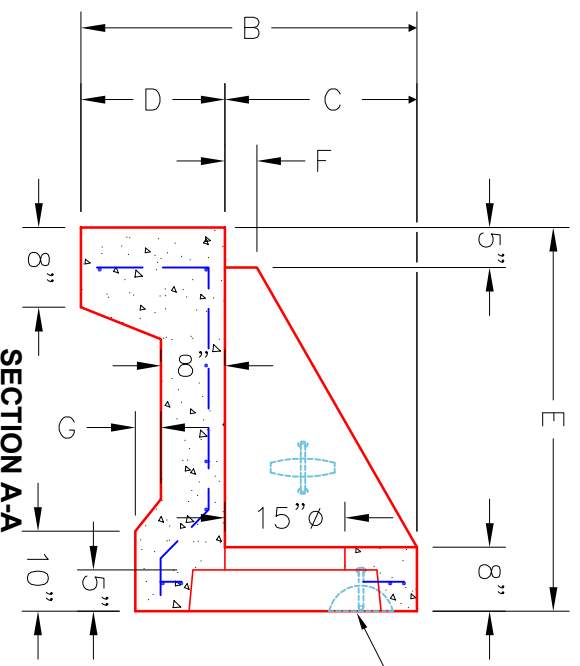

SECTION A-A

- NOTES:**
1. CONCRETE: 4500 PSI @ 28 DAYS.
 2. REINFORCING: #4 BAR @ 12" C/C E.W.-GRADE 60, (WITH 2" CONCRETE COVER MINIMUM)
 3. REINFORCING BARS TO BE TACK WELDED OR TIED.
 4. DRAWING TO BE USED IN CONJUNCTION WITH KYTC STD. DRAWING RDH-020-03 AND THE STANDARD SPECIFICATIONS FOR ROAD AND BRIDGE CONSTRUCTION.
 5. $\frac{1}{2}$ " CHAMFER ON ALL EXPOSED EDGES.

PRODUCTION WORK ORDER

QUALITY CONTROL CHECKLIST	PRODUCT I.D.: HWSF15	DESCRIPTION: KYTC 15" ϕ SLOPED & FLARED HEADWALL
<input type="checkbox"/> ALL DIMENSIONS CORRECT. <input type="checkbox"/> LIFTERS INSTALLED. <input type="checkbox"/> STEPPED HF CORRECT SIZE. <input type="checkbox"/> REINFORCING CORRECT. <input type="checkbox"/> DISSIPATOR BLOCK INSTALLED. <input type="checkbox"/> EDGES CHAMFERED. <input type="checkbox"/> ALL PATCHWORK ACCEPTABLE.	PRODUCT VIEW: RIGHT SIDE UP	CUSTOMER: STOCK
	PLANT: BEAVER DAM, KY.	PROJECT: STOCK INVENTORY
	WEIGHT: 3,161 LBS.	STRUCTURE ID.: N/A
	TOP SECTION JOINT: N/A	QUOTE/SALES ORDER NO: N/A
	BASE SECTION JOINT: N/A	CHECK: J.H. ROSS, PE
	QC CHECK INITIALS:	DATE: 09/15/22
		SCALE: NTS
		PG. 1 of 1

