

**ISOMETRIC VIEW**

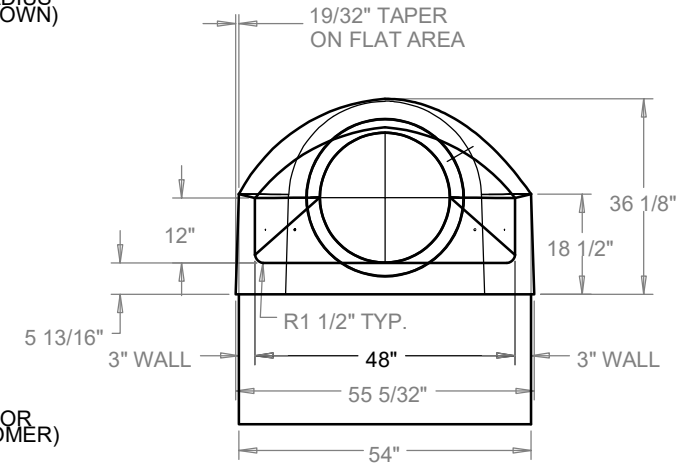

**GENERAL NOTES:**

1. FLARED END SECTION IS MANUFACTURED AND TESTED IN ACCORDANCE WITH ASTM C-76 OR ASTM C-655 AND AASHTO M-170 SPECIFICATIONS.
2. ALL PIPE JOINTS MEET ASTM C-443 AND C-361 SPECIFICATIONS.
3. INSTALL REINFORCED CONCRETE PIPE PER ASTM C-1479-STANDARD PRACTICE FOR INSTALLATION OF PRECAST CONCRETE PIPE.
4. FLARED END SECTION REINFORCING IS IN ACCORDANCE WITH ASTM C-76.
5. WEIGHT SHOWN IS CALCULATED USING 150 LBS. PER CUBIC FT. UNIT WEIGHT OF CONCRETE.

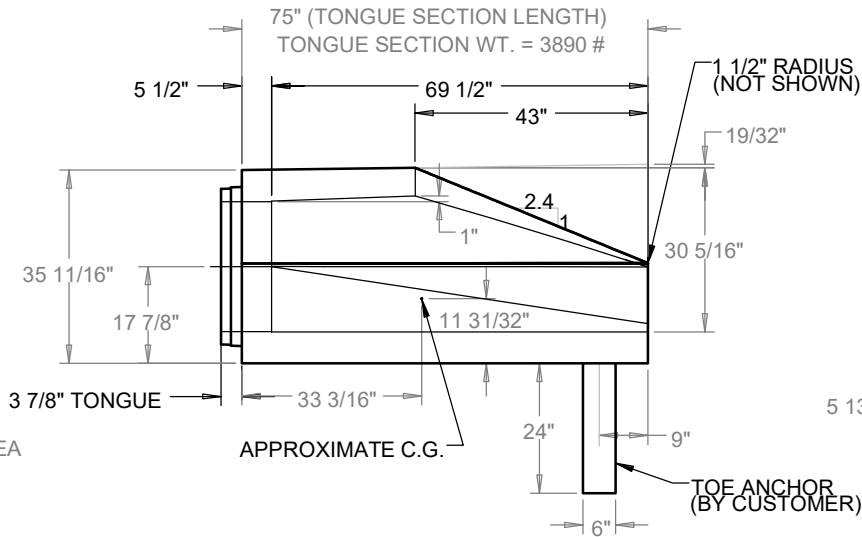
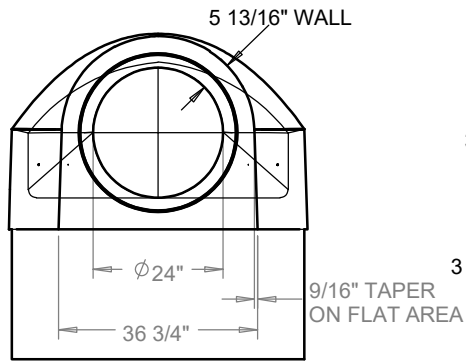
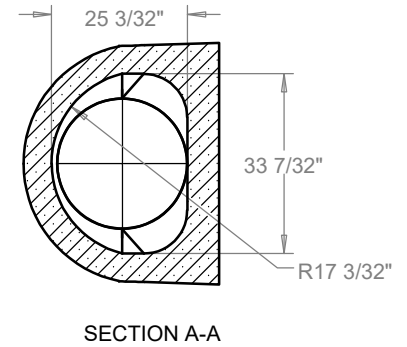
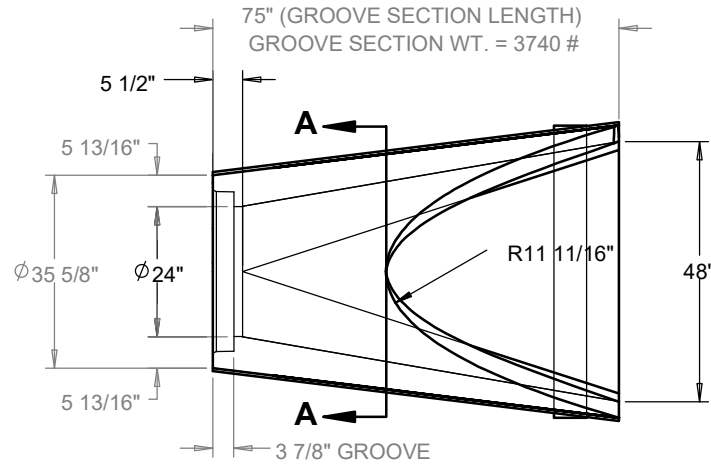

**INFRASTRUCTURE PRECAST, INC.**  
 981 WEST 7TH ST., BEAVER DAM, KY. 42320  
 PHONE: (270) 363-2238, FAX: (270) 298-7424

DRAWING DATE: SEPTEMBER 2, 2022

DRAWING NAME: 24-FES-TYPE 2

SCALE: NTS

CATALOG I.D.: 24-RCP-FES

WEB ADDRESS: WWW.ICASTINC.COM

**24"Ø REINFORCED  
 CONCRETE FLARED  
 END SECTION  
 (TYPE 2)**