

THIS DRAWING IS INTENDED TO BE PRINTED IN COLOR.

LATEST REVISION 3-14-23

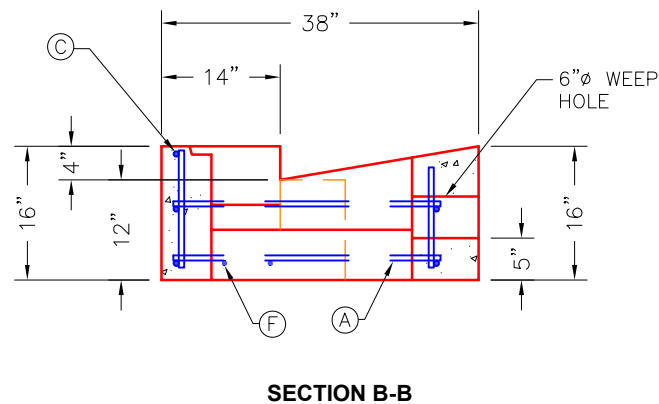
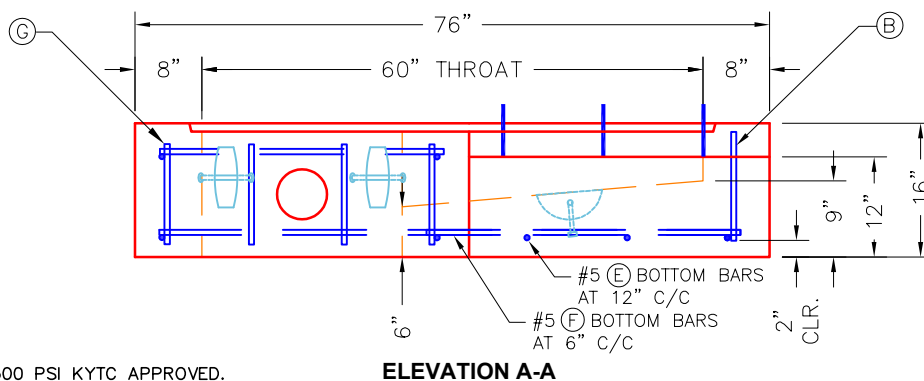
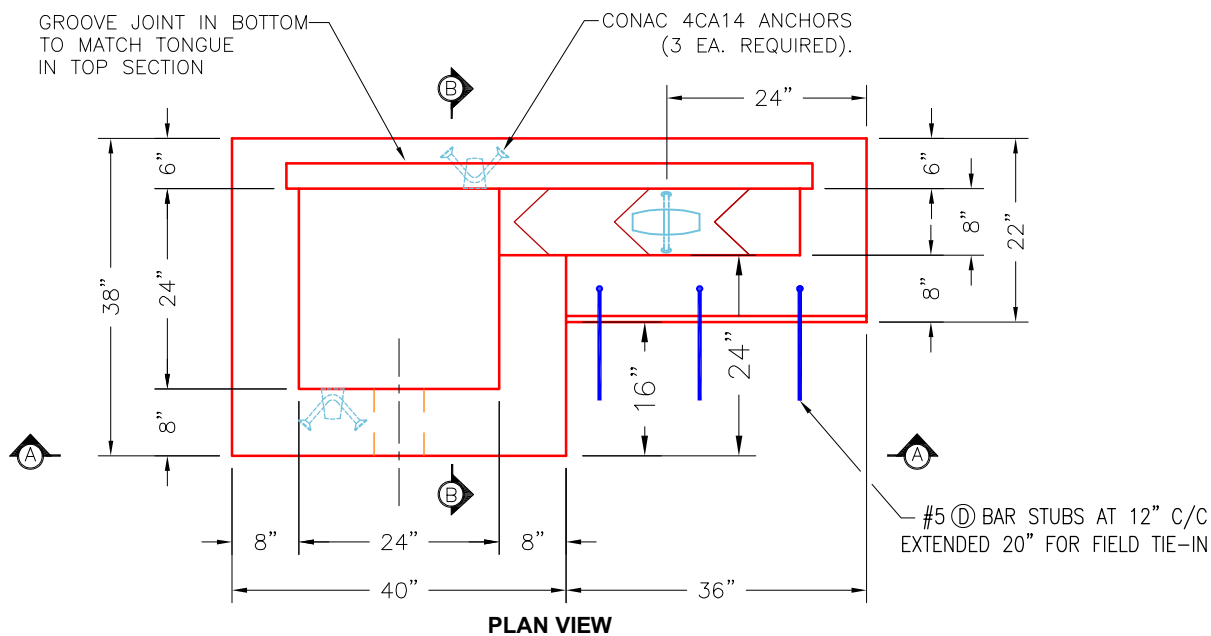

REINFORCING CUT LIST

BAR	QTY.	MATERIAL	LENGTH	SHAPE	TOTAL WEIGHT
ⓐ	6	#5 BAR	34"	STR.	18 LBS.
ⓑ	12	#5 BAR	12"	STR.	12 LBS.
ⓒ	3	#5 BAR	72"	STR.	19 LBS.
ⓓ	3	#5 BAR	29"	BENT	8 LBS.
ⓔ	3	#5 BAR	18"	STR.	14 LBS.
ⓕ	3	#5 BAR	38"	STR.	10 LBS.
ⓖ	4	#5 BAR	12"	STR.	4 LBS.

**\*KYTC STATE PRODUCT\***

~NOTES:

1. CONCRETE: 4,500 PSI KYTC APPROVED.
2. REINFORCING: #5 BAR-SEE CHART (GRADE 60)
3. REINFORCING BARS TO BE TACK WELDED OR TIED.
4. LIFTING ANCHOR POCKETS TO BE GROUTED AFTER SETTING BY CONTRACTOR.
5. DRAWING TO BE USED IN CONJUNCTION WITH KYTC STD. DRAWINGS  
RDB-280-06, RDB-281-03, RDB-282-04, RDB-283-04, RDB-400-05,  
RDB-410-06, RDB-420-05 AND THE STANDARD SPECIFICATIONS FOR ROAD  
AND BRIDGE CONSTRUCTION.

PRODUCTION WORK ORDER

PRODUCT I.D.: CBITB5-BL

DESCRIPTION: KYTC CBI B 5' TOP PHASE BOTTOM (LEFT HAND)

QUALITY CONTROL CHECKLIST

- ALL DIMENSIONS CORRECT.
- LIFTERS INSTALLED.
- CASTING AT CORRECT LOCATION.
- REINFORCING CORRECT.
- SURFACE QUALITY ACCEPTABLE.
- KYTC STANDARD THROAT CORRECT.
- ALL PATCHWORK ACCEPTABLE.

PRODUCT VIEW: RIGHT SIDE UP

CUSTOMER: STOCK

PLANT: BEAVER DAM, KY.

PROJECT: STOCK

WEIGHT: 2,525 LBS.

STRUCTURE ID.: N/A

TOP SECTION JOINT: N/A

SALES ORDER NO.: N/A

BOTTOM SECTION JOINT: SHIP-LAP GROOVE

PC: J.H. ROSS, P.E.

DRAWING: N. RICHARDS

QC CHECK INITIALS:

DATE: 03/14/23

SCALE: NTS

PG. 1 of 1

