

Structure ID: MTD

P3 MH048RSVF

MH RISER Custom Ht T/G

P5) 24" x 24" - CASTING HEIGHT - 0" P4) 48" - MH FLAT TOP SPECIAL (HOE-280T) F/G - 12" P3) 48" - MH RISER Custom Ht T/G - 55" P2) 48" - MH RISER Custom Ht T/G - 27" P1) 48" - MH BASE T/n - 18" 1) JOINT WRAP - 0.065"x6"x50' CONSEAL CS212 1) JOINT WRAP PRIMER - CONSEAL CS-75 (1 gal.) 1) ASSEMBLY REQUIRED 1) This Structure Includes a Cast-in Item 1) CASTING - HOE 280T F/G 3) 48" - Conseal CS-102 1.00" (Double) 1) 24" x 24" - Conseal CS-102 1.00" (Double) 1) Hole - 12	0 lb 1535 lb 3794 lb 1886 lb 2588 lb 0 lb 0 lb 0 lb 0 lb 182 lb 0 lb 0 lb 0 lb ----- Structure Total: 9985 lb
--	---

Structure Notes:

1. PER ASTM C478 SPECIFICATIONS.
2. CONCRETE = 4,000 PSI AT 28 DAYS.
3. CASTING BY ICAST (HOE 280T F/G CAST-IN).
4. P2 & P3 RISERS TO BE MECHANICALLY ATTACHED.

REINFORCING PER ASTM A615 (GRADE 60).

- TOP SLAB (As .62) #5 BARS AT 6" C.C.E.W..
- RISER/WALLS (As .12)
- FLOOR (As .31) #5 BARS AT 12" C.C.E.W.

Rim: 920.16' Rim to Invert: 2.66' Slack: 0.92" Sump: 81" Step Position:

Position	Elev	Angle	Ext. (cw)	Pipe	Pipe OD	Connector	Hole	Horz Size	Up (⌋)	Offset
Invert 1	917.5'	0°	0"	8" HDPE	9.1"	Hole 12	12"	12.129"	29.75"	0"
Invert 2										
Invert 3										
Invert 4										
Invert 5										
Invert 6										
Invert 7										
Invert 8										

RIGHT-SIDE UP VIEW (int. dimensions)

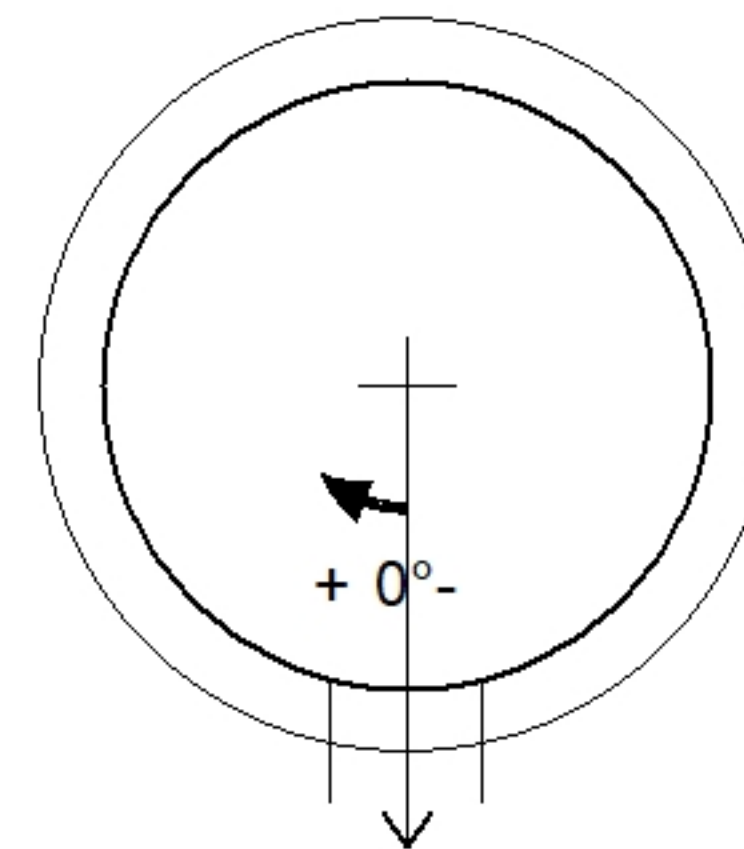
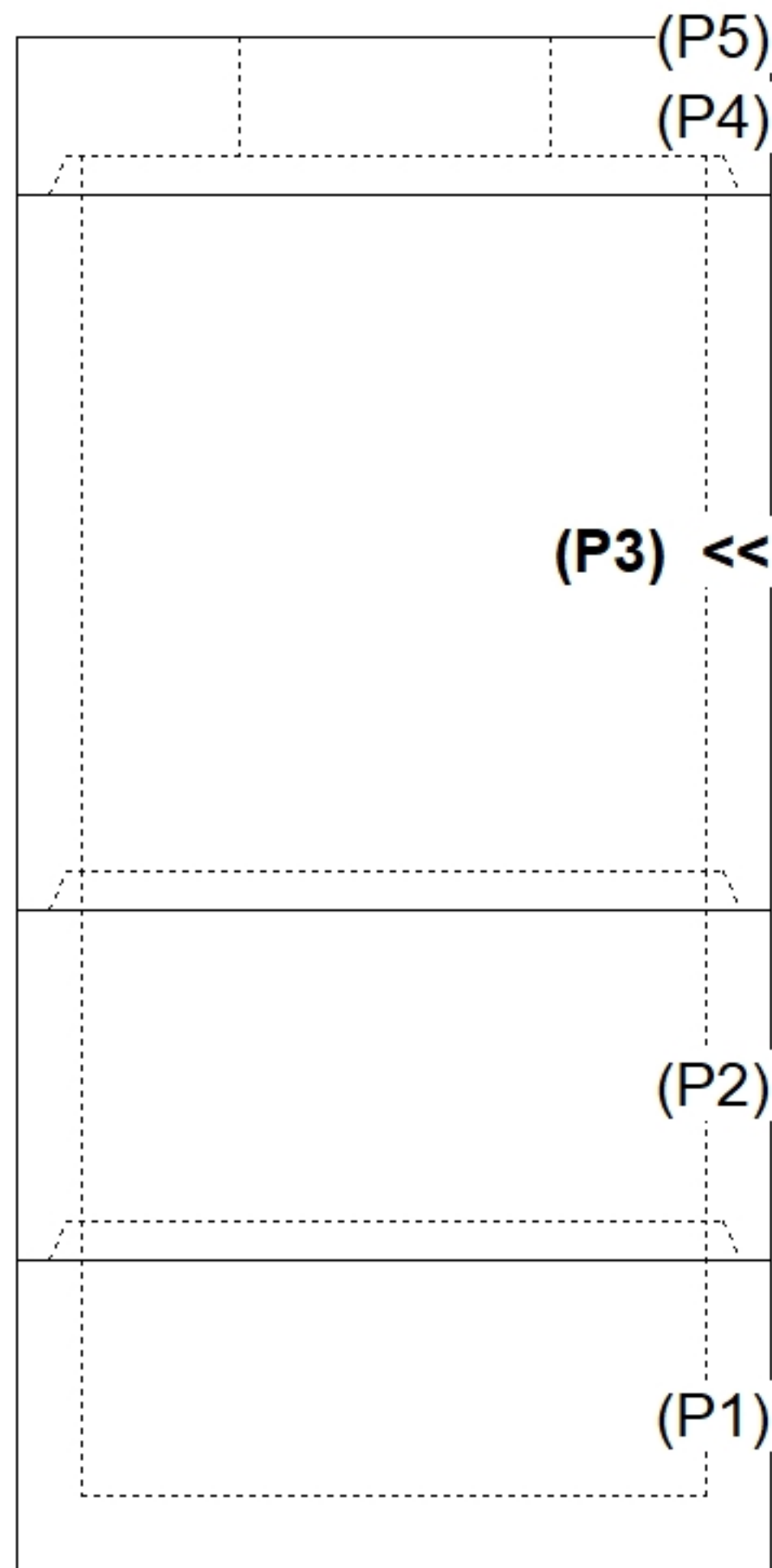

Invert: 1
 Degree: 0°
 Horz: 0"
 Hole: 12"
 Up(⌋): 29.75"

INSIDE WALL DIMENSIONS

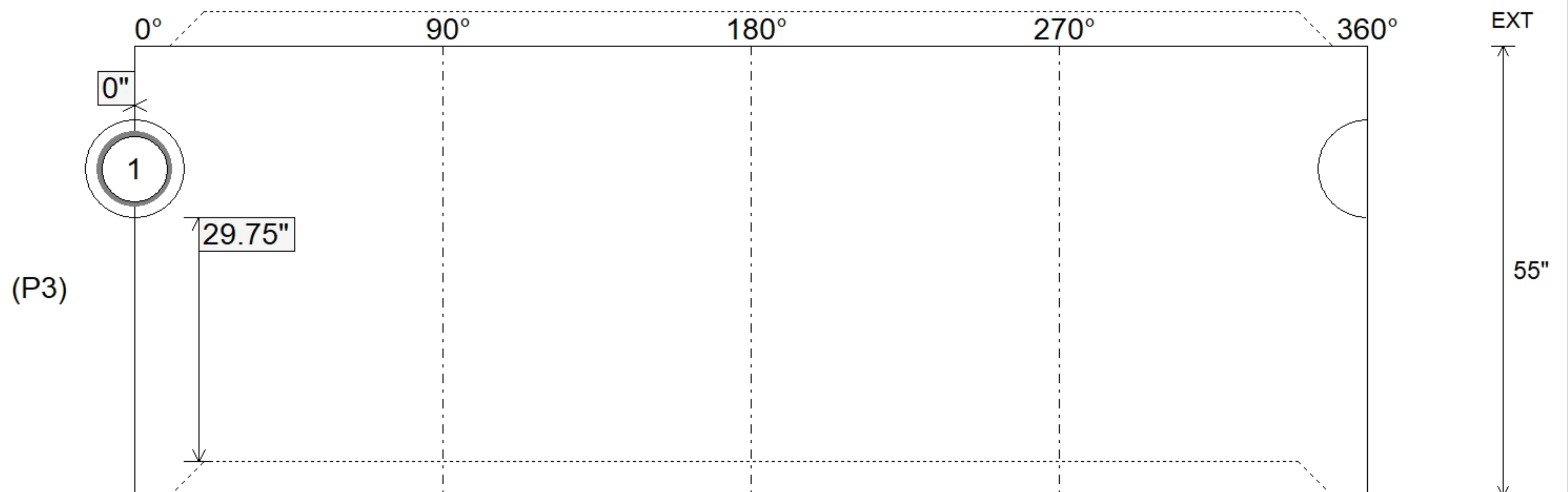

Coating (Int):	Seam Up: Tongue Seam Dn: Groove	Wall Thickness: 5" Floor Height: 0"	Height (Int): 55" Height (Ext): 55"
Coating (Ext):			Weight (Net): 3794 lb Volume (Net): 0.97cu.yd