

Job Name: 26-2087 839373 Georgetown Commons
Job Location: Georgetown, KY
Contractor: Contech Engineering Solutions

PC: C. Goff
 TECH: S. Felletter
 Plant: Beaver Dam



Structure ID: 15-CS-12
 Spec: Storm-Pipe Centered
 Type: STM.MH
 Size: 144"

Rim: 866.5'
 Invert: 856.15'
 Rim to Invert: 10.35'

Sump: 108.036"
 Floor (Top): 847.147"
 Floor Height: 14"

Floor (Bot): 845.98'
 Overall Height: 20'
 Slack: 6.236"

Structure Notes:
 4" CASTING BY OTHERS

LIFTING ANCHORS TO BE INSTALLED
 ON THE OUTSIDE OF THE STRUCTURE

ICAST TO INSTALL BRACKETS ONLY

CONTECH'S LOGO AS WELL AS THE
 INLET AND OUTLET MUST BE
 STENCILED ONTO THE STRUCTURE

STRUCTURE SUMMARY:

P6) 24" - CASTING HEIGHT - 4"	0 lb
P5) 144" - MH FLAT TOP SPEC. (2 - 24"Ø HOLES) F/G - 18"	23623 lb
P4) 144" - MH RISER T/G - 36"	19370 lb
P3) 144" - MH RISER T/G - 84"	41809 lb
P2) 144" - MH RISER T/G - 60"	32283 lb
P1) 144" - MH MONOBASE 14F, Custom Ht T/n - 24"	39578 lb
1) CVSTENCILING	0 lb
1) ASSEMBLY REQUIRED - BRACKETS ONLY	0 lb
4) 144" - Conseal CS-102 1.00"	0 lb
2) Hole - 44	0 lb

Structure Total:	156662 lb

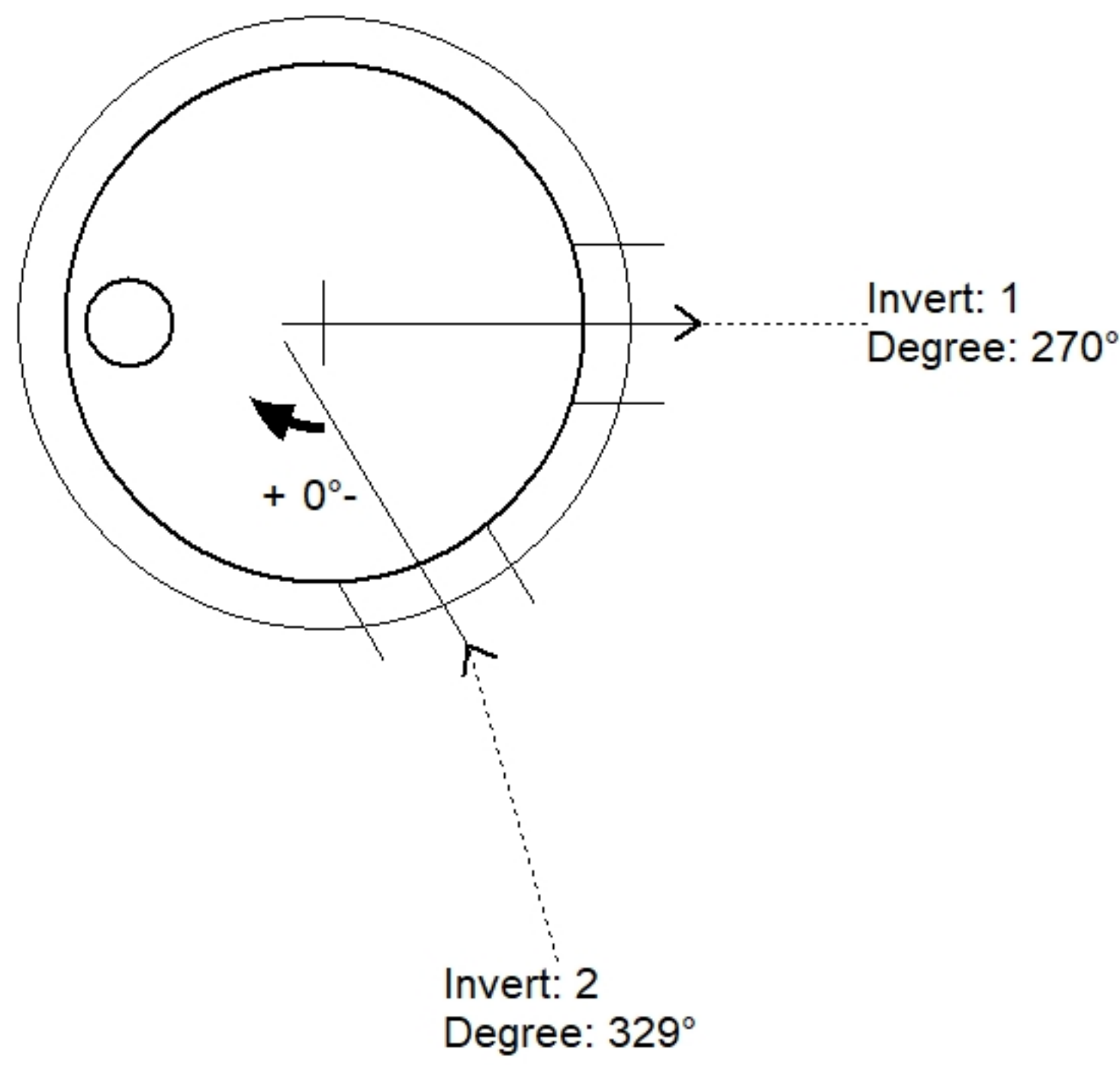

Position	Elev	Angle	Pipe	Pipe OD	Hole	Connector	Up (")	Ref
Rim	866.5'							
Reducer								
Invert 1	856.15'	270°	36" HDPE	41.7"	44"	Hole 44	14.036"	P3
Invert 2	856.15'	329°	36" HDPE	41.7"	44"	Hole 44	14.036"	P3
Invert 3								
Invert 4								
Invert 5								
Invert 6								
Invert 7								
Invert 8								

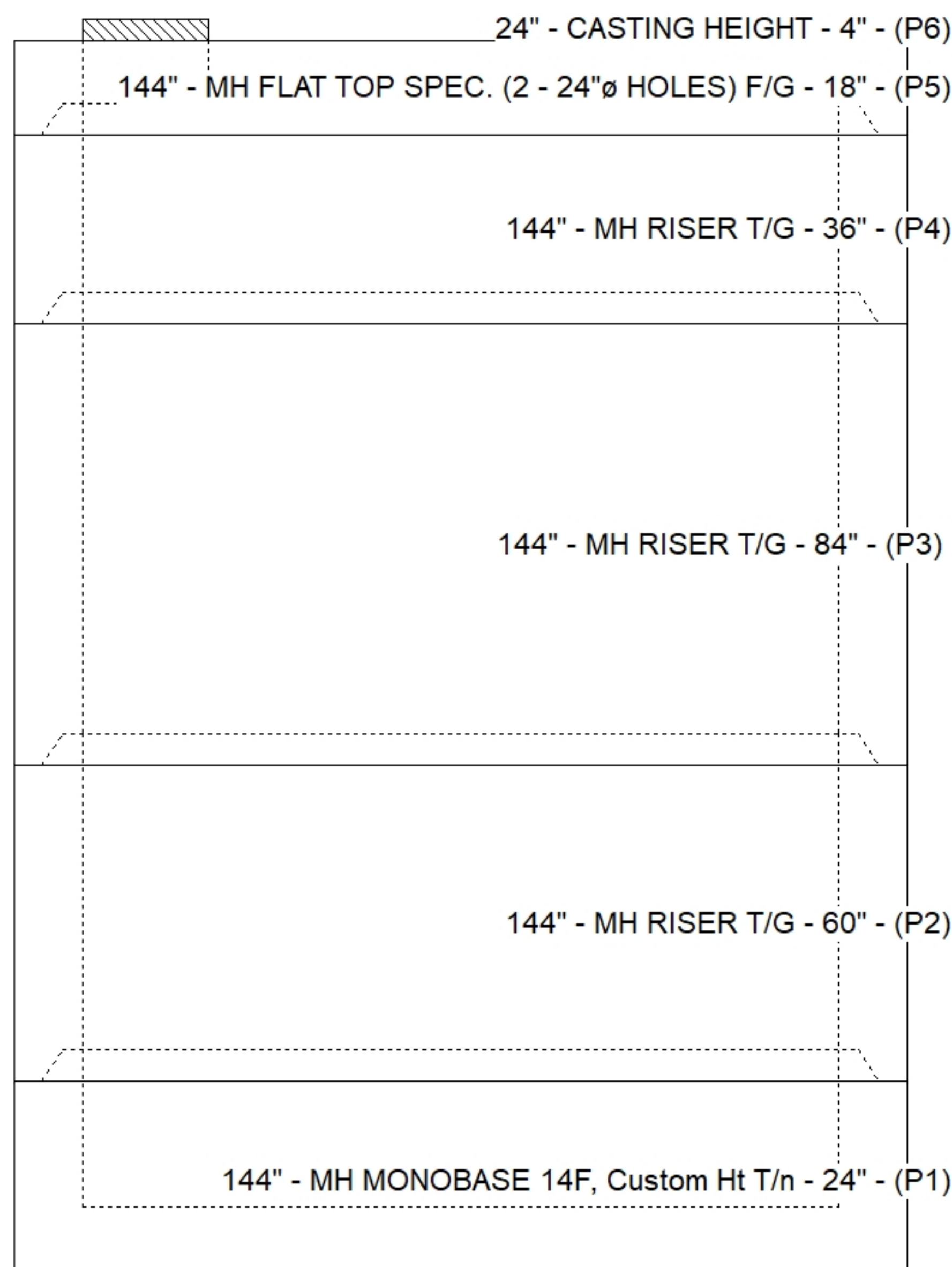

Default - Interior Dimensions

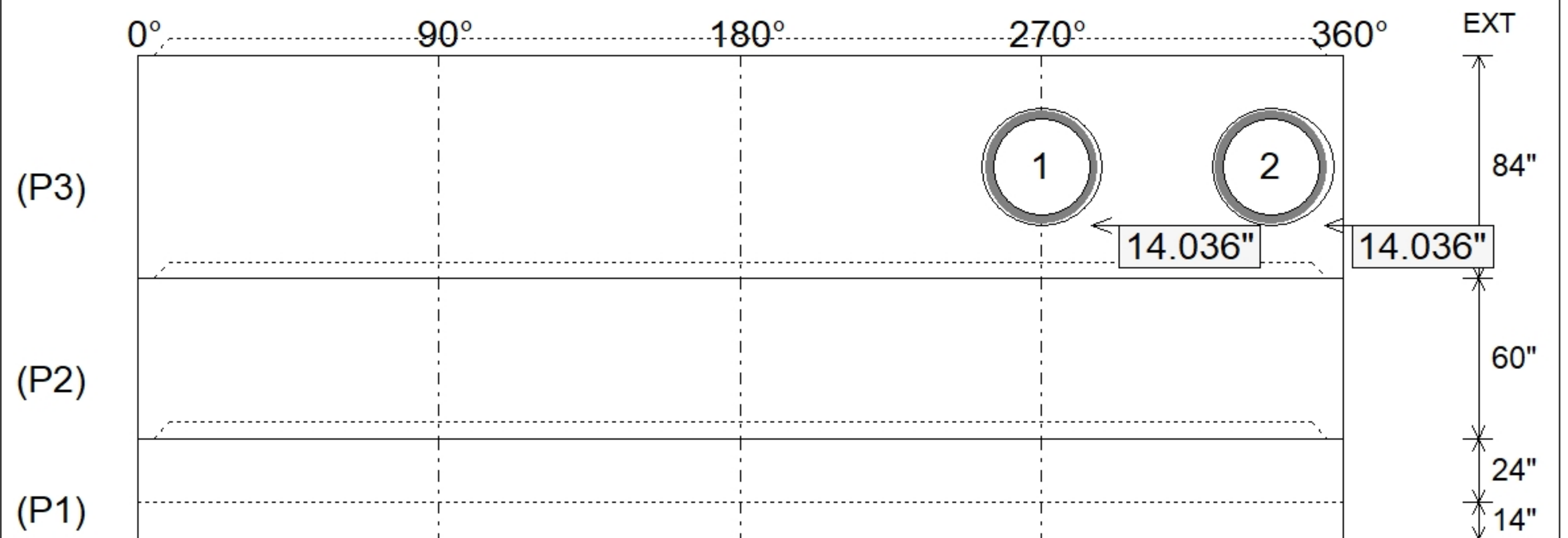

Submittal Drawing
 4/28/2026 12:27:49 PM

SUBMITTAL
 APPROVED BY: