

26-2037 830068 Marketplace

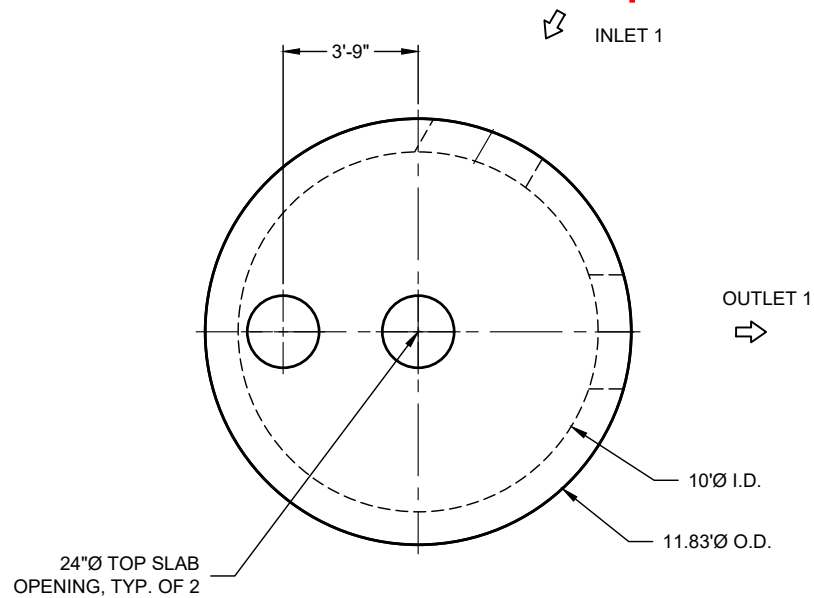

PLAN VIEW
INTERNALS NOT SHOWN

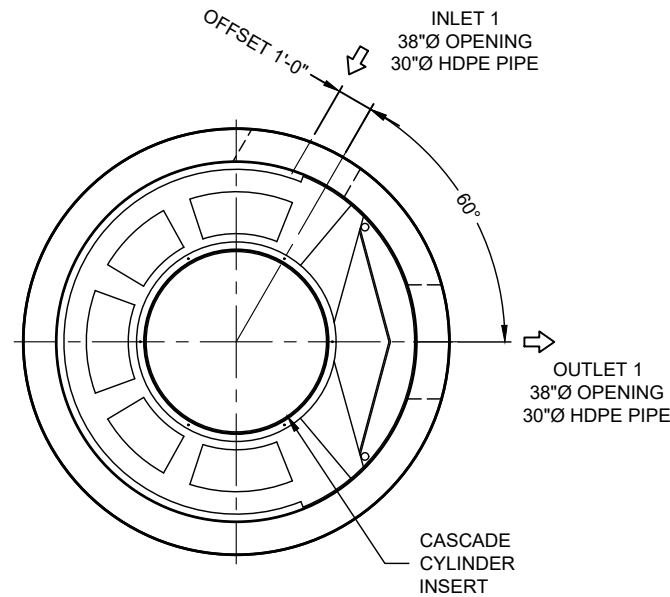

PLAN VIEW FOR PIPE ORIENTATION
TOP SLAB NOT SHOWN

INTERNAL COMPONENTS TO BE INSTALLED ON SITE BY CONTECH FIELD CONSULTANT. PRECASTER TO SHIP ALL INTERNAL COMPONENTS WITH STRUCTURE

SEE INSTALLATION NOTE A

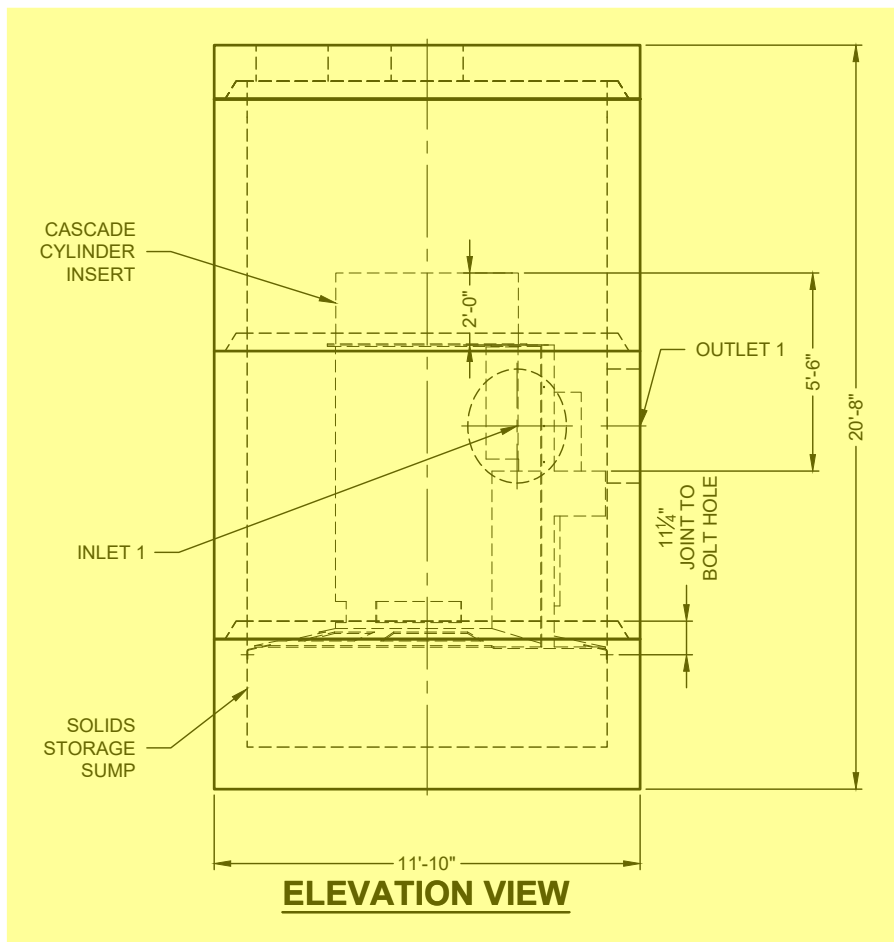

ELEVATION VIEW

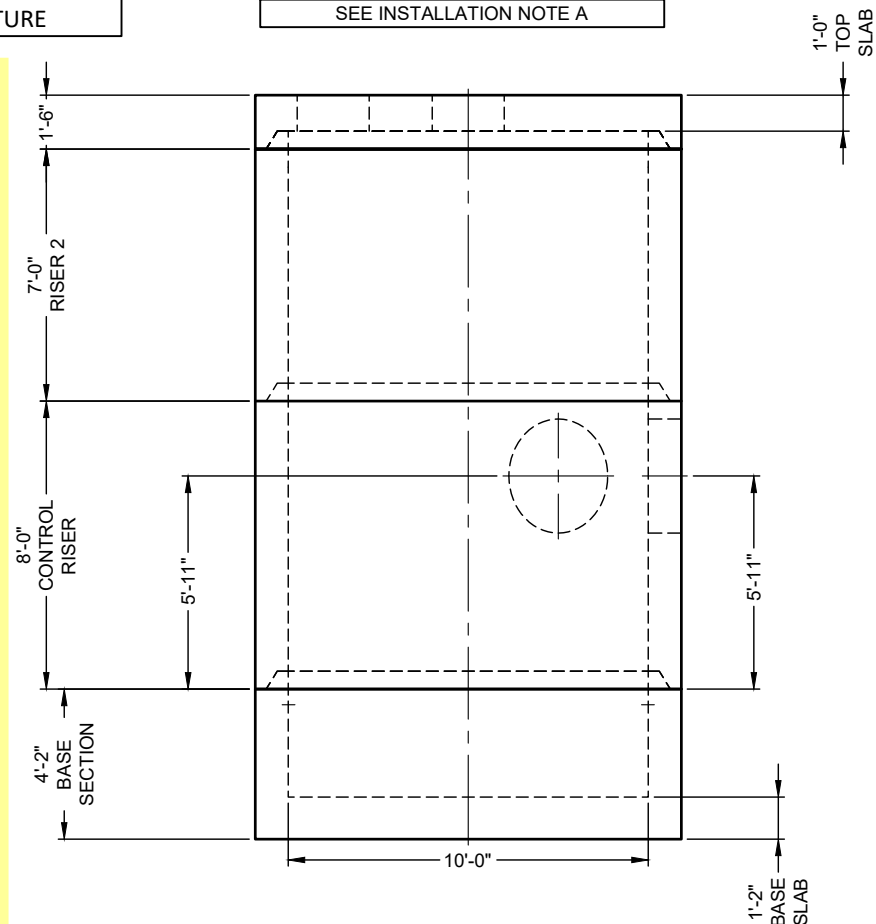

PRECAST COMPONENTS
INTERNALS NOT SHOWN

MATERIAL LIST

COUNT	DESCRIPTION	PART NUMBER	PROVIDED BY	INSTALLED BY
1	CS-10 CYLINDER INSERT, STD	325-003976	CONTECH	CONTRACTOR
1	CS-10 CYLINDER TOP	325-003988	CONTECH	CONTRACTOR
8	CS-10 ALUMINUM INSTALLATION BRACKETS	325-003971	CONTECH	PRECASTER
1	CS-10 HARDWARE KIT	325-003977	CONTECH	CONTRACTOR
1	SEALANT FOR JOINTS		PRECASTER	CONTRACTOR
2	24"Ø X 4" FRAME AND COVER, EJ #41600389, OR EQUIV.	325-000350	CONTECH	CONTRACTOR

GENERAL NOTES

- DESIGN LOADING - AASHTO HS-20
- ALL PRECAST CONCRETE MANUFACTURED PARTS SHALL CONFORM TO ASTM C-478, WITH MINIMUM CONCRETE STRENGTH OF 4000 PSI AT 28 DAYS
- JOINT SEALANT SHALL CONFORM TO ASTM C-990 OR ASTM C-443
- GROUND WATER ELEVATION ASSUMED AT OUTLET INVERT
- MANUFACTURING TOLERANCE = +/- 1/2-INCH
- SOME HIDDEN LINES MAY BE OMITTED FOR CLARITY

INSTALLATION NOTES

- PRECASTER TO SHIP ACCESS CASTINGS WITH STRUCTURE
- REFER TO CONTECH ASSEMBLY INSTRUCTIONS FOR ADDITIONAL INFORMATION.
- PRECASTER TO INSTALL INTERNAL COMPONENTS PRIOR TO SHIPPING UNLESS INSTRUCTED OTHERWISE BY CONTECH
- PIPE OPENINGS SHALL BE STENCILED "INLET" OR "OUTLET" AS APPROPRIATE
- APPLYING ALIGNMENT MARKS ON ALL PIECES OF MULTIPLE PIECE ASSEMBLIES IS ENCOURAGED
- IF STRUCTURE IS DELIVERED IN MULTIPLE SECTIONS, EACH PIECE SHALL BE LABELED WITH THE CONTECH PROJECT NUMBER, SEQUENCE NUMBER AND SITE DESIGNATION

SITE INFORMATION

RIM ELEV. = 833.75+/-
 TOP OF STRUCTURE = 833.33
 INLET PIPE 1 INVERT ELEV. = 821.50
 INLET PIPE 1 DIAMETER AND MATERIAL = 30"Ø HDPE
 OUTLET PIPE INVERT ELEV. = 821.50
 OUTLET PIPE DIAMETER AND MATERIAL = 30"Ø HDPE
 OUTSIDE BOTTOM OF STRUCTURE ELEV. = 812.66

STRUCTURE WEIGHT

APPROXIMATE HEAVIEST PICK = 37500 LBS.
 STRUCTURE IS DELIVERED IN 4 PIECES

TOP SLAB = 17500 LBS.
 RISER 2 = 34500 LBS.
 CONTROL RISER = 37500 LBS.
 BASE SECTION = 36000 LBS.

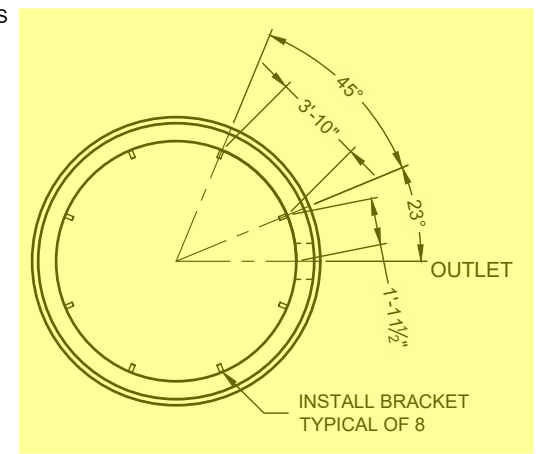

SUPPORT BRACKET LAYOUT PLAN VIEW

The design and information shown on this drawing is the property of CONTECH Construction Products, Inc. or one of its affiliated companies ("CONTECH"). Neither this drawing, nor any part thereof, may be used, reproduced, or transmitted in any form or by any means, electronic or mechanical, including photocopying, recording, or by any information storage and retrieval system, without the prior written consent of CONTECH. Failure to comply with these terms and conditions shall constitute a breach of contract and shall constitute a disclaimer of any liability or responsibility for such use. If discrepancies between the supplied information upon which the drawing is based and actual field conditions are encountered as site work progresses, these are to be immediately reported to the design engineer. CONTECH accepts no liability for designs based on missing, incomplete or inaccurate information supplied by others.

MARK	DATE	REVISION DESCRIPTION	BY

CS-10 - 830068-15
 MARKETPLACE - FRANKFORT PIKE
 GEORGETOWN, KY
 SITE DESIGNATION: #65 WQU

CONTECH
 ENGINEERED SOLUTIONS LLC
 A CONTECH COMPANY
 810 Centre Pointe Dr., Suite 400, West Chester, OH 45380
 800.338.1122 513.645.7000 513.645.7803 FAX
CASCADE separator
 FOR PATENT INFORMATION, GO TO www.contech.com/PP

DATE: 4/6/2026

DESIGNED: MDB	DRAWN: MDB
CHECKED: MSB	APPROVED: MDB
PROJECT No.: 830068	SEQUENCE No.: 15
SHEET: 1	OF 1

C:\USERS\MICHAEL.BEAVRONEDRIVE - THE QUIKRETE COMPANIES\DYNAMICS\865 - CONTECH - PROJECTS\830068\PRODUCTS\830068-15-CS-10-CONFAB.DWG 4/6/2026 1:53 PM

26-2037 830068 Marketplace

V1600-3 V1610-3 Assembly

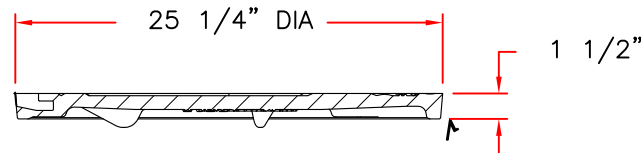
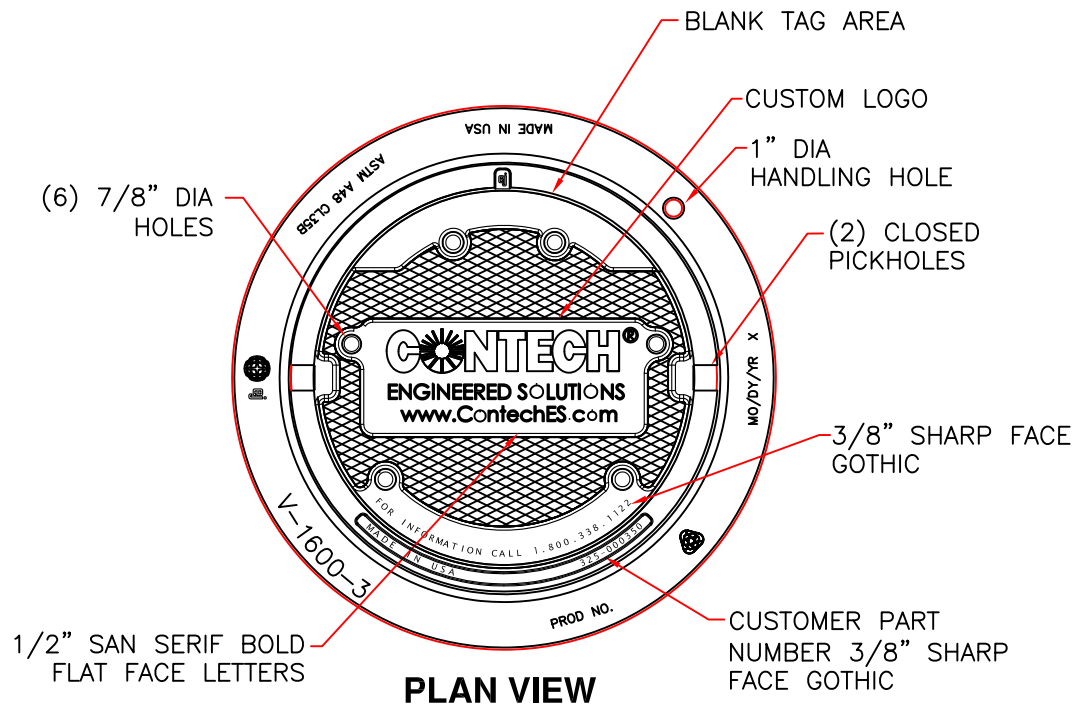

COVER SECTION

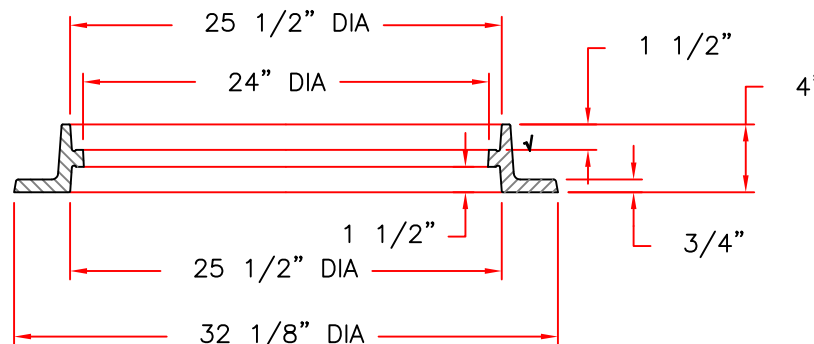

RING SECTION

Product Number
41600389

Design Features

- Materials
 - Frame Gray Iron (CL35B)
 - Cover Gray Iron (CL35B)

- Design Load Heavy Duty
- Open Area n/a
- Coating Undipped
- √ Designates Machined Surface

Certification

- ASTM A48
- Country of Origin: USA

Major Components

- 41600310
- 41600374

Drawing Revision

- 05/02/2008 Designer: DEW
- 6/20/2017 Revised By: DAE

Disclaimer

Weights (lbs./kg) dimensions (inches/mm) and drawings provided for your guidance. We reserve the right to modify specifications without prior notice.

CONFIDENTIAL: This drawing is the property of EJ GROUP, Inc., and embodies confidential information, registered marks, patents, trade secret information, and/or know how that is the property of EJ GROUP, Inc. Copyright © 2012 EJ GROUP, Inc. All rights reserved.

Contact

800 626 4653
ejco.com

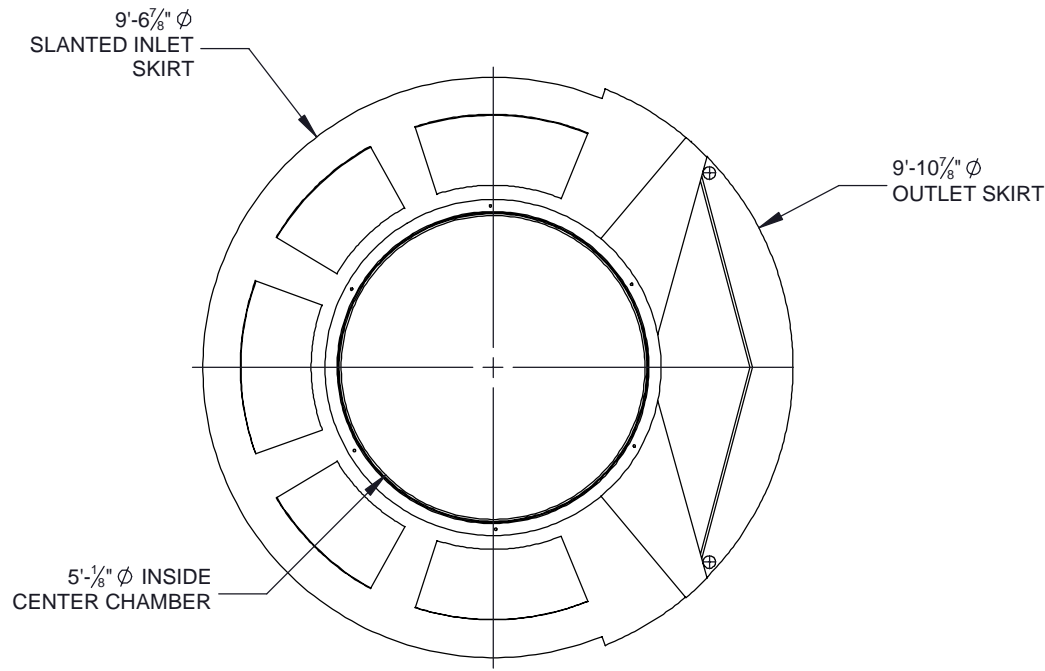

PLAN VIEW

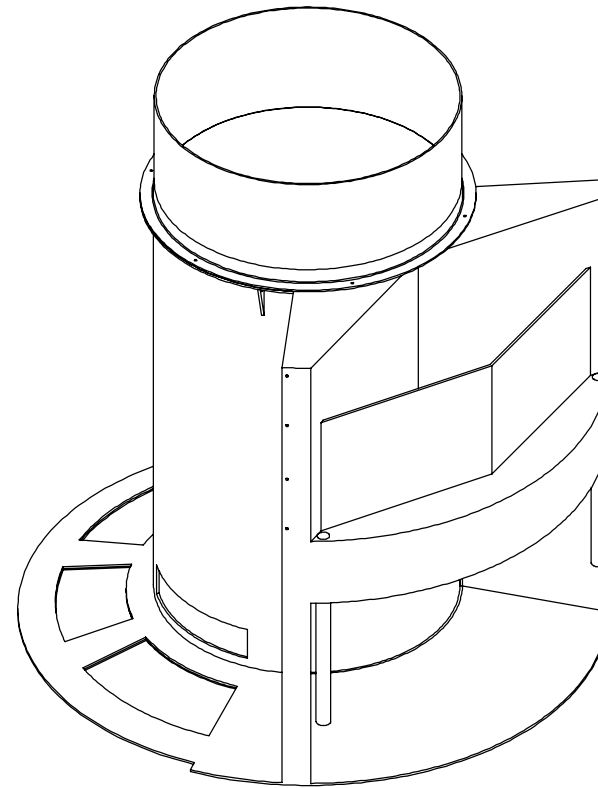

ISOMETRIC VIEW

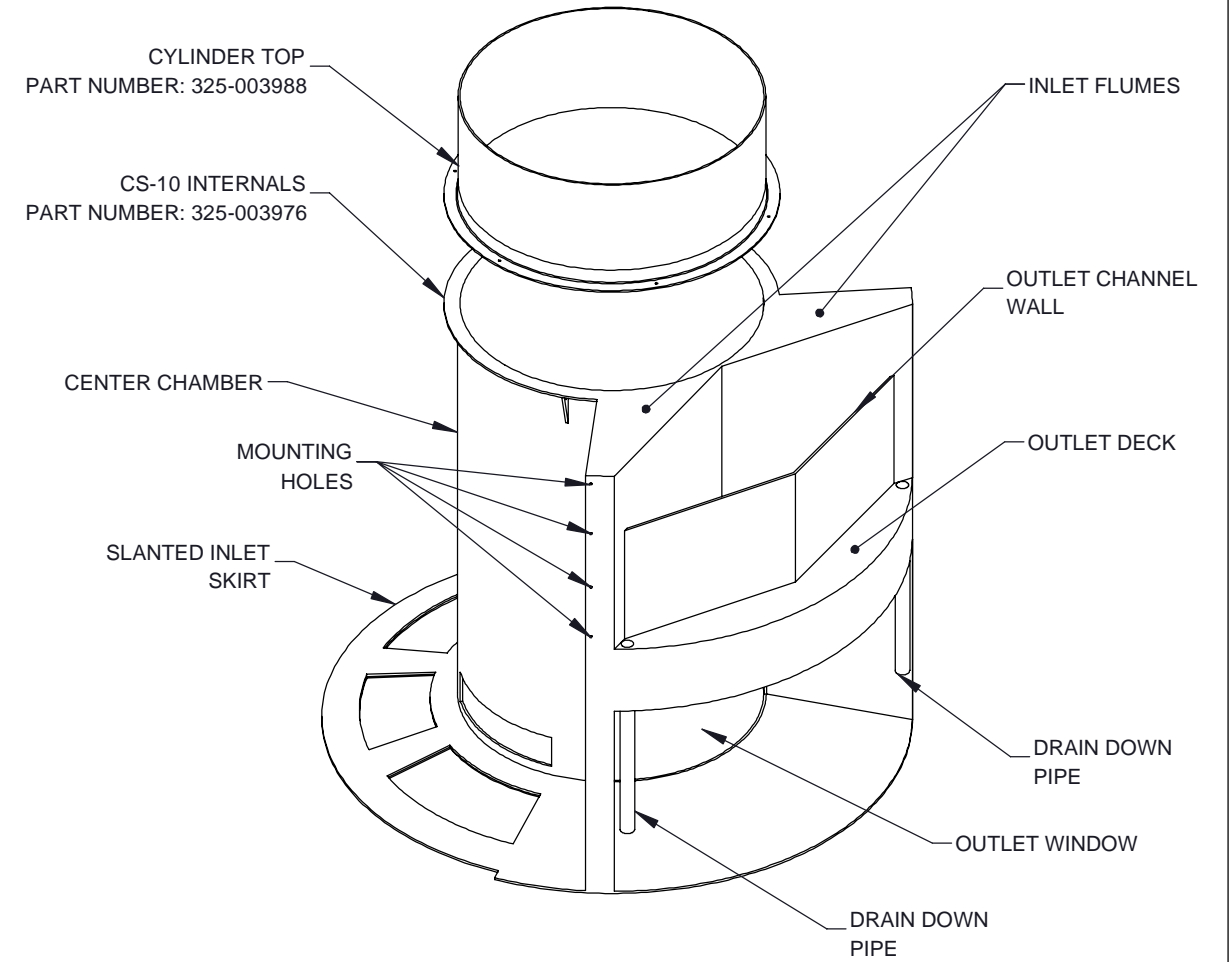

EXPLODED ISOMETRIC VIEW

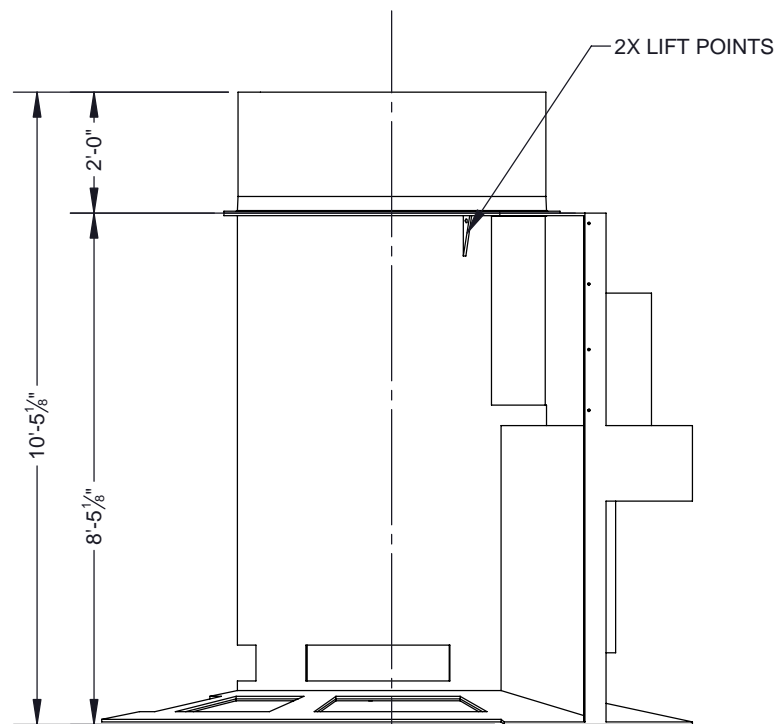

ELEVATION VIEW

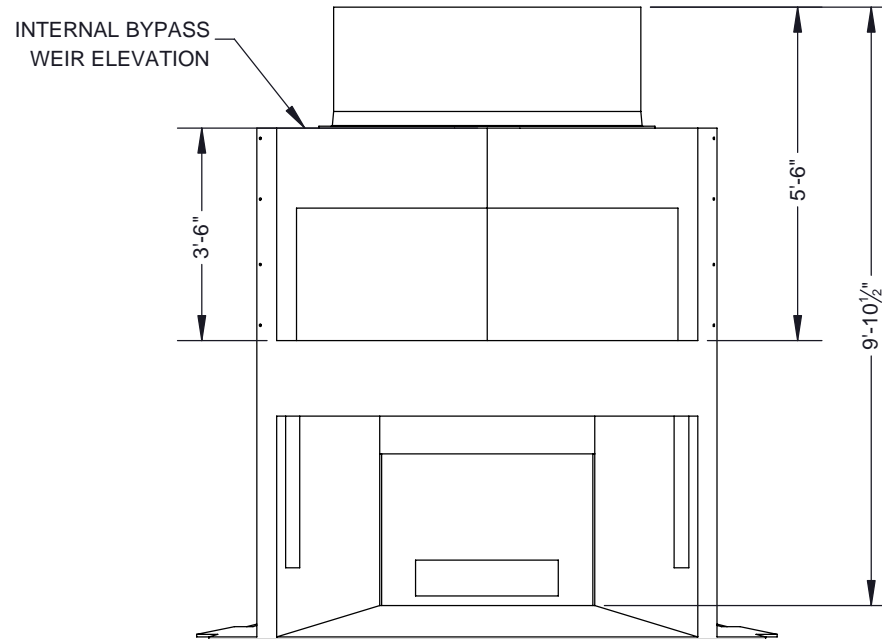

ELEVATION VIEW: OUTLET SIDE

- NOTES:
1. SEE CASCADE SEPARATOR INSTALLATION GUIDE FOR ADDITIONAL INFORMATION

The design and information shown on this drawing is provided as a service to the project owner, engineer and contractor by Contech Engineered Solutions LLC, or one of its affiliated companies ("Contech"). Neither this drawing, nor any part thereof, may be used, reproduced or modified in any manner without the prior written consent of Contech. Failure to comply is done at the user's own risk and Contech expressly disclaims any liability or responsibility for such use.

If discrepancies between the supplied information upon which the drawing is based and actual field conditions are encountered as site work progresses, these discrepancies must be reported to Contech immediately for re-evaluation of the design. Contech accepts no liability for designs based on missing, incomplete or inaccurate information supplied by others.

CASCADE
separator™

CONTECH
ENGINEERED SOLUTIONS LLC

www.ContechES.com
9025 Centre Pointe Dr., Suite 400, West Chester, OH 45069
800-338-1122 513-645-7000 513-645-7993 FAX

REFERENCE DETAIL
INTERNALS CS-10 &
CYLINDER TOP
CASCADE SEPARATOR

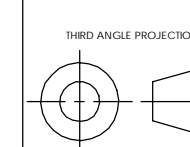

UNLESS OTHERWISE SPECIFIED
DIMENSIONS ARE IN INCHES

TOLERANCES:
FRACTIONAL $\pm 1/16$
ANGLES ± 1 DEGREE
TWO PLACE DECIMAL ± 0.06
THREE PLACE DECIMAL ± 0.030

PART NUMBER: 325-003976 & 003988		
APPROVED BY: M. BROOKS	DRAWN BY: J. BELL	
APPROVED BY DATE: 2021.10.21	DRAWN BY DATE: 2021.09.15	REV: C
SCALE: N/A	SHEET 1 OF 1	