

**Structure ID: K1B**

**P1 MH096BA24**

**MH BASE T/n**

P6) 24" - CASTING HEIGHT - 7" P5) 96" - MH FLAT TOP w/ 24" Conc. Hole F/G - 17" P4) 96" - MH RISER NO STEPS T/G - 36" P3) 96" - MH RISER NO STEPS T/G - 96" P2) 96" - MH RISER NO STEPS T/G - 84" P1) 96" - MH BASE T/n - 24" 1) JOINT WRAP - 0.065"x6"x50' CONSEAL CS212 1) JOINT WRAP PRIMER - CONSEAL CS-75 (1 gal.) 1) ASSEMBLY REQUIRED - BRACKETS ONLY 1) CASTING - HOE MC-375 F/C Storm 4) 96" - Conseal CS-102 1.00" 2) Hole - 26	0 lb 10473 lb 8968 lb 23002 lb 20926 lb 12831 lb 0 lb 0 lb 0 lb 271 lb 0 lb 0 lb ----- Structure Total: 76471 lb
--	---

**Structure Notes:**

1. PER ASTM C478 SPECIFICATIONS.
2. CONCRETE = 4,000 PSI AT 28 DAYS.
3. CASTING BY ICAST (HOE MC-375 F/C "STORM").

REINFORCING PER ASTM A615 (GRADE 60).

- TOP SLAB (As .62) #5 BARS AT 6" C.C.E.W.
- RISER/WALLS (As .24)
- FLOOR (As .47) #5 BARS AT 8" C.C.E.W.

Rim: 565'    Rim to Invert: 11.07'    Slack: 0.84"    Sump: 132"    Step Position:

Position	Elev	Angle	Ext. (cw)	Pipe	Pipe OD	Connector	Hole	Horz Size	Up (L)	Offset
Invert 1										
Invert 2										
Invert 3										
Invert 4										
Invert 5										
Invert 6										
Invert 7										
Invert 8										

RIGHT-SIDE UP VIEW (int. dimensions)

UPSIDE-DOWN VIEW (int. dimensions)

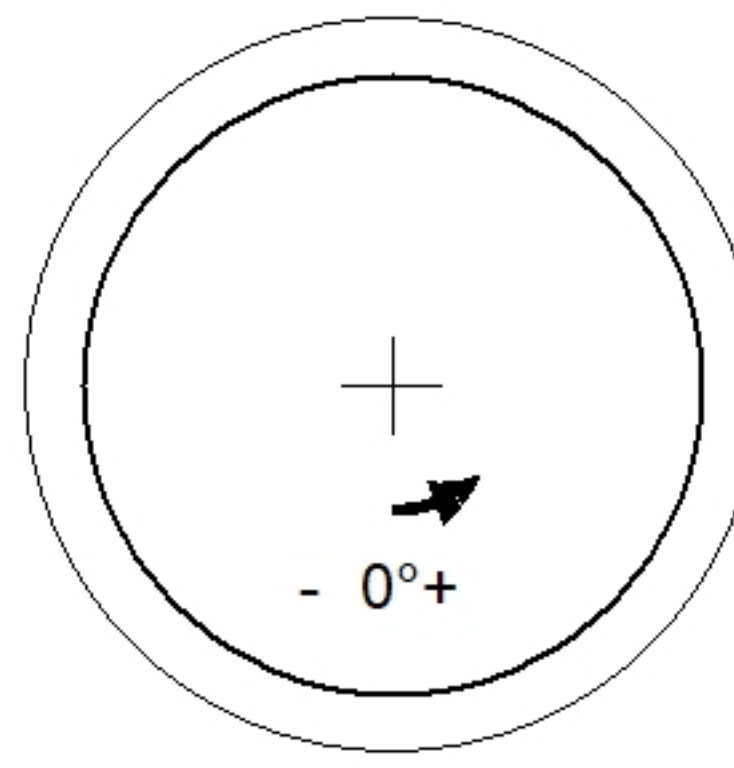
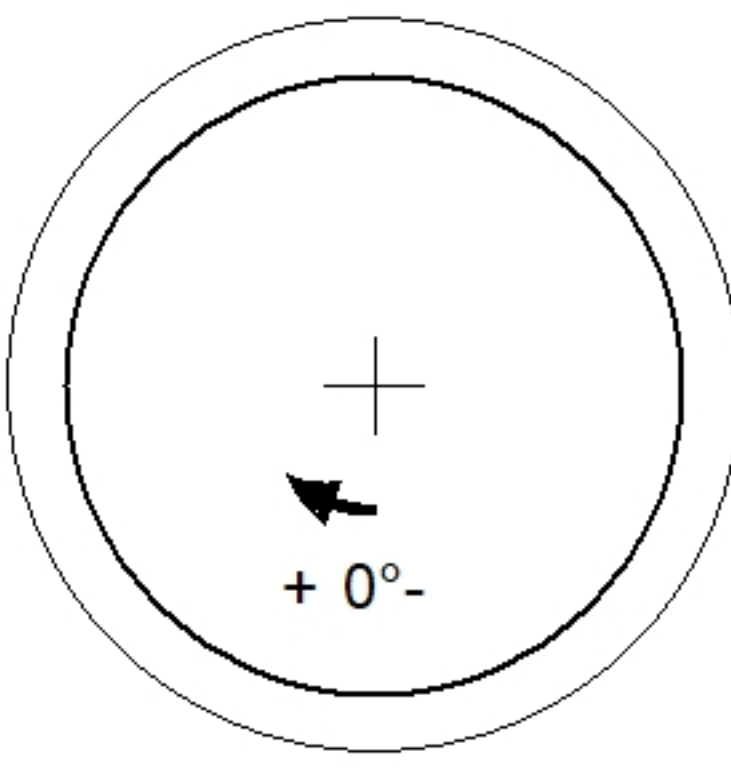
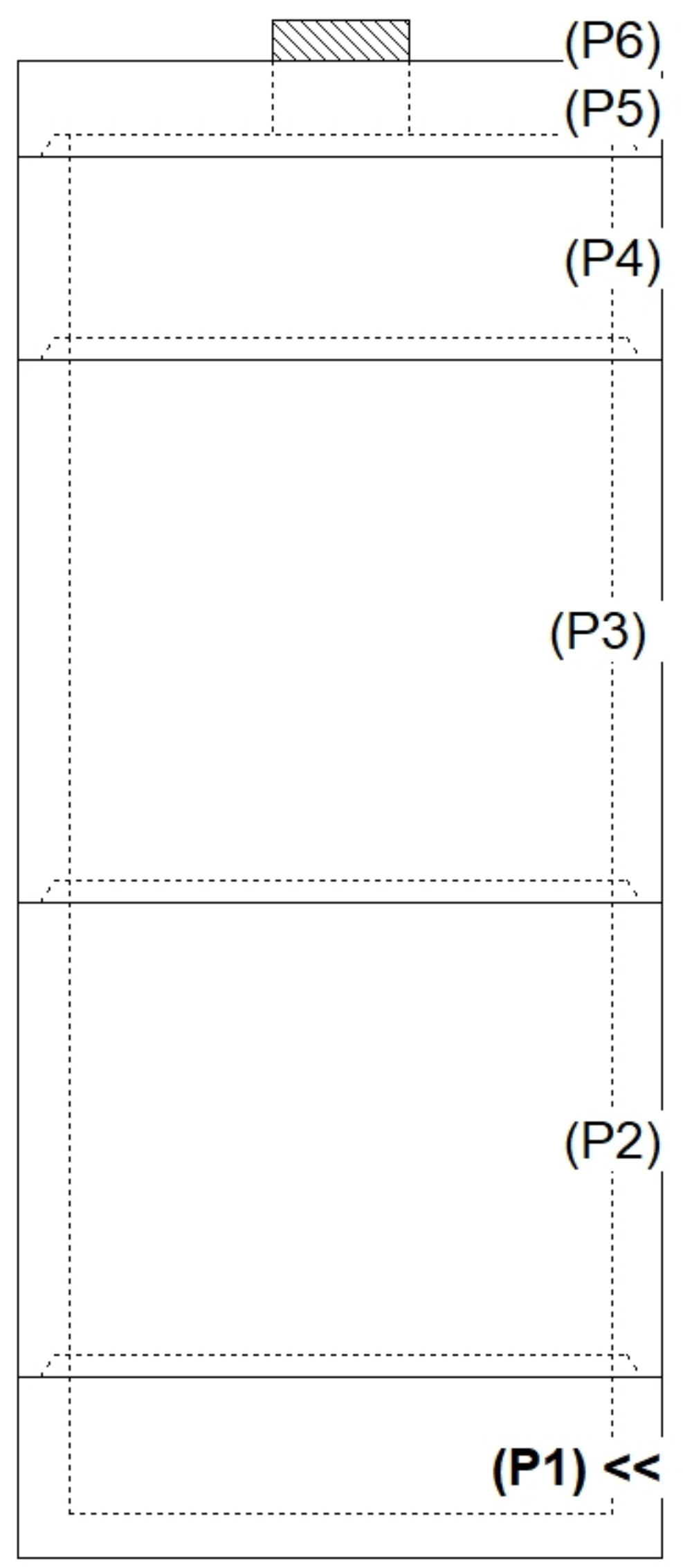

INSIDE WALL DIMENSIONS

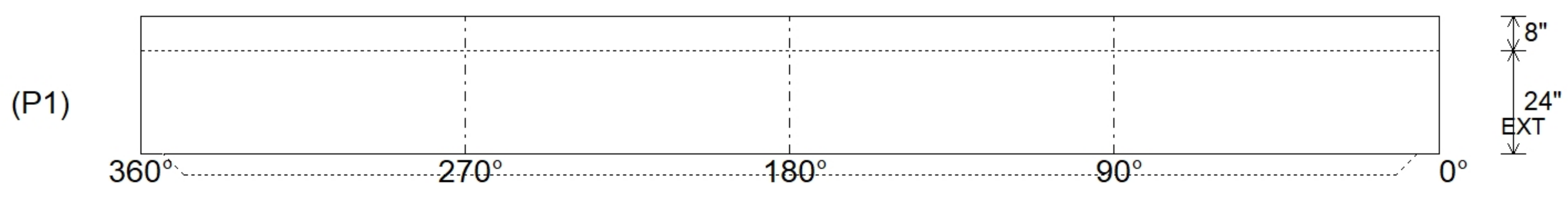

Coating (Int):	Seam Up: Tongue	Wall Thickness: 9"	Height (Int): 24"
Coating (Ext):	Seam Dn: n/a	Floor Height: 8"	Height (Ext): 32"
		Weight (Net): 12831 lb	
		Volume (Net): 3.28cu.yd	