

Job Name: 26-1941 ADS Williams Mill
 Job Location: Antiock, TN
 Contractor: ADS Advanced Drainage Systems, Inc.

Plant: Beaver Dam
 4/20/2026 9:49:55 AM

Tech: S. Felletter
 PC: C. Goff



Structure ID: A1A

P6 GR3

GRADE RING F/F

- P7) 24" - CASTING HEIGHT - 7"
- P6) 24" - GRADE RING F/F - 3"
- P5) 120" - MH FLAT LID w/24in CON Hole F/G - 18"
- P4) 120" - MH RISER NO STEPS T/G - 30"
- P3) 120" - MH RISER NO STEPS T/G - 96"
- P2) 120" - MH RISER NO STEPS T/G - 96"
- P1) 120" - MH BASE T/n - 24"
- 1) JOINT WRAP - 0.065"x6"x50' CONSEAL CS212
- 1) JOINT WRAP PRIMER - CONSEAL CS-75 (1 gal.)
- 1) ASSEMBLY REQUIRED - BRACKETS ONLY
- 1) CASTING - HOE MC-375 F/C Storm
- 4) 120" - Conseal CS-102 1.00" (Double)
- 2) Hole - 34

0 lb
 202 lb
 16678 lb
 11396 lb
 34643 lb
 36468 lb
 25064 lb
 0 lb
 0 lb
 0 lb
 271 lb
 0 lb
 0 lb

 Structure Total: 124722 lb

- Structure Notes:**
1. PER ASTM C478 SPECIFICATIONS.
 2. CONCRETE = 4,000 PSI AT 28 DAYS.
 3. CASTING BY ICAST (HOE MC-375 F/C "STORM").
- REINFORCING PER ASTM A615 (GRADE 60).
- TOP SLAB (As .62) #5 BARS AT 6" C.C.E.W..
 - RISER/WALLS (As .36)
 - FLOOR (As .47) #5 BARS AT 8" C.C.E.W.

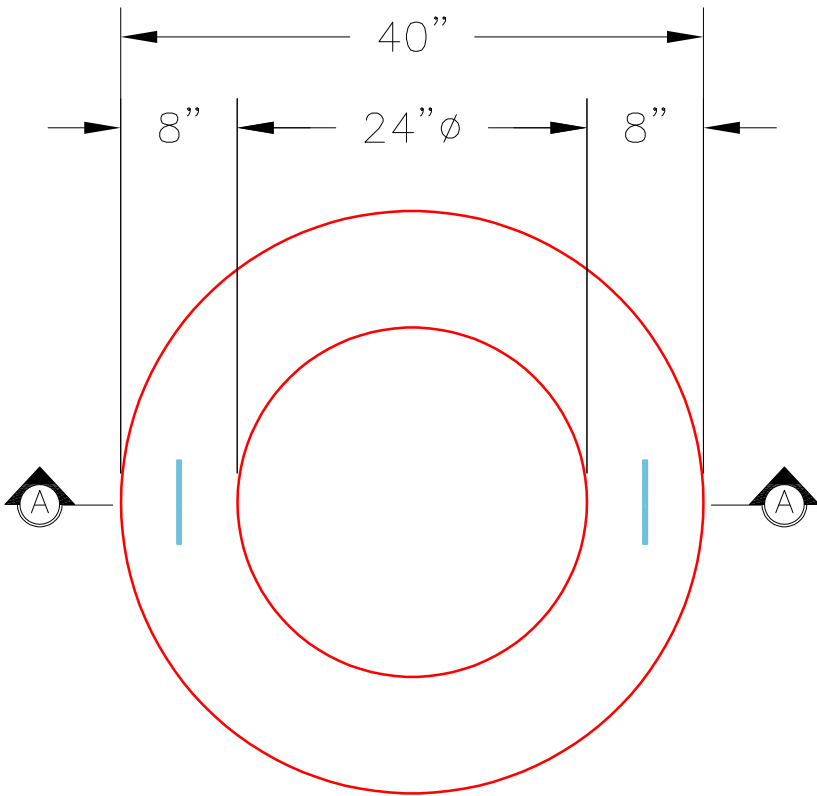

PLAN VIEW

NOTES:

1. GRADE RINGS MEET OR EXCEED THE FOLLOWING SPECIFICATIONS:
 - CONCRETE: 4,000 PSI @ 28 DAYS.
 - REINFORCING: (1) #3 HOOP CENTERED (GRADE 60)
2. WEIGHT: 3" 202 LBS.

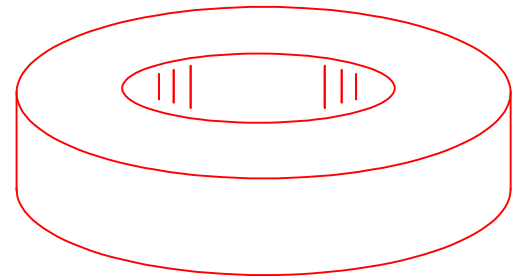

ISOMETRIC VIEW

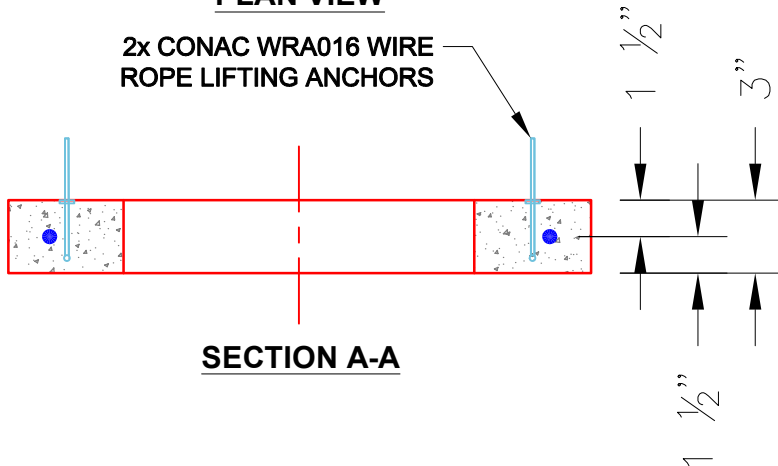

SECTION A-A

Coating (Int):
 Coating (Ext):

Seam Up: Flat
 Seam Dn: Flat

Wall Thickness: 8"

Height (Ext): 3"

Weight (Net): 202 lb
 Volume (Net): 0.05cu.yd