

Structure ID: 10-CS-6

P2 MH072RS84

MH RISER T/G

P4) 30" - CASTING HEIGHT - 4" P3) 72" - MH FLAT TOP SPEC. (30" ECC HOLE) F/G - 15" P2) 72" - MH RISER T/G - 84" P1) 72" - MH BASE T/n - 84" 1) CVSTENCILING 1) ASSEMBLY REQUIRED 2) 72" - Conseal CS-102 1.00" 2) Hole - 32	0 lb 4661 lb 11853 lb 15564 lb 0 lb 0 lb 0 lb 0 lb 0 lb _____ 32078 lb	Structure Notes: 4" CASTING BY OTHERS LIFTING ANCHORS TO BE INSTALLED ON THE OUTSIDE OF THE STRUCTURE ICAST TO INSTALL THE INTERNALS CONTECH'S LOGO AS WELL AS THE INLET AND OUTLET MUST BE STENCILED ONTO THE STRUCTURE
--	--	---

Structure Total: 32078 lb

Rim: 1005' Rim to Invert: 11' Slack: 5.036" Sump: 60.036" Step Position: 0°

Position	Elev	Angle	Ext. (cw)	Pipe	Pipe OD	Connector	Hole	Horz Size	Up ()	Offset
Invert 1	994'	270°	202.633"	24" HDPE	27.8"	Hole 32	32"	33.16"	-32.964"	0"
Invert 2	995.5'	90°	67.544"	24" HDPE	27.8"	Hole 32	32"	33.16"	-14.964"	0"
Invert 3										
Invert 4										
Invert 5										
Invert 6										
Invert 7										
Invert 8										

RIGHT-SIDE UP VIEW (int. dimensions)

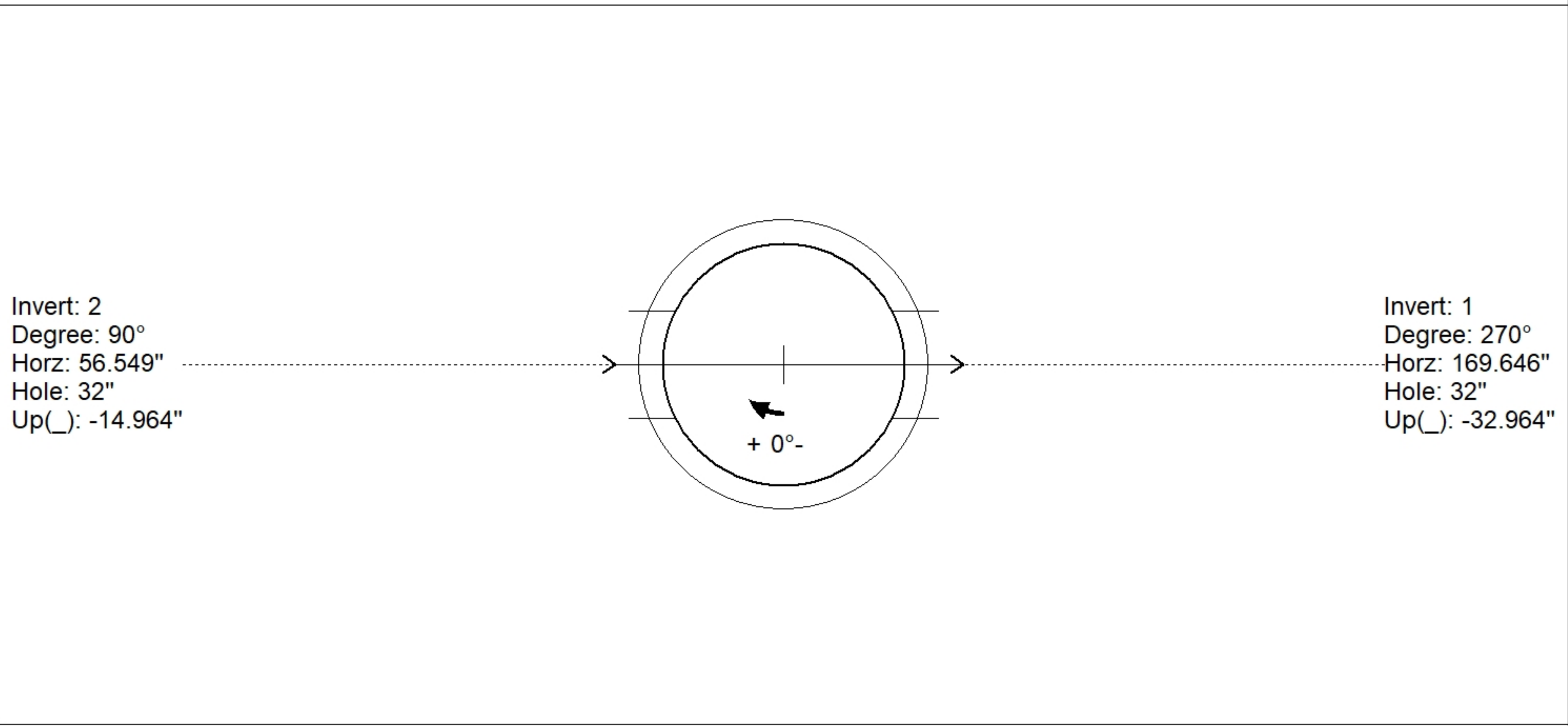
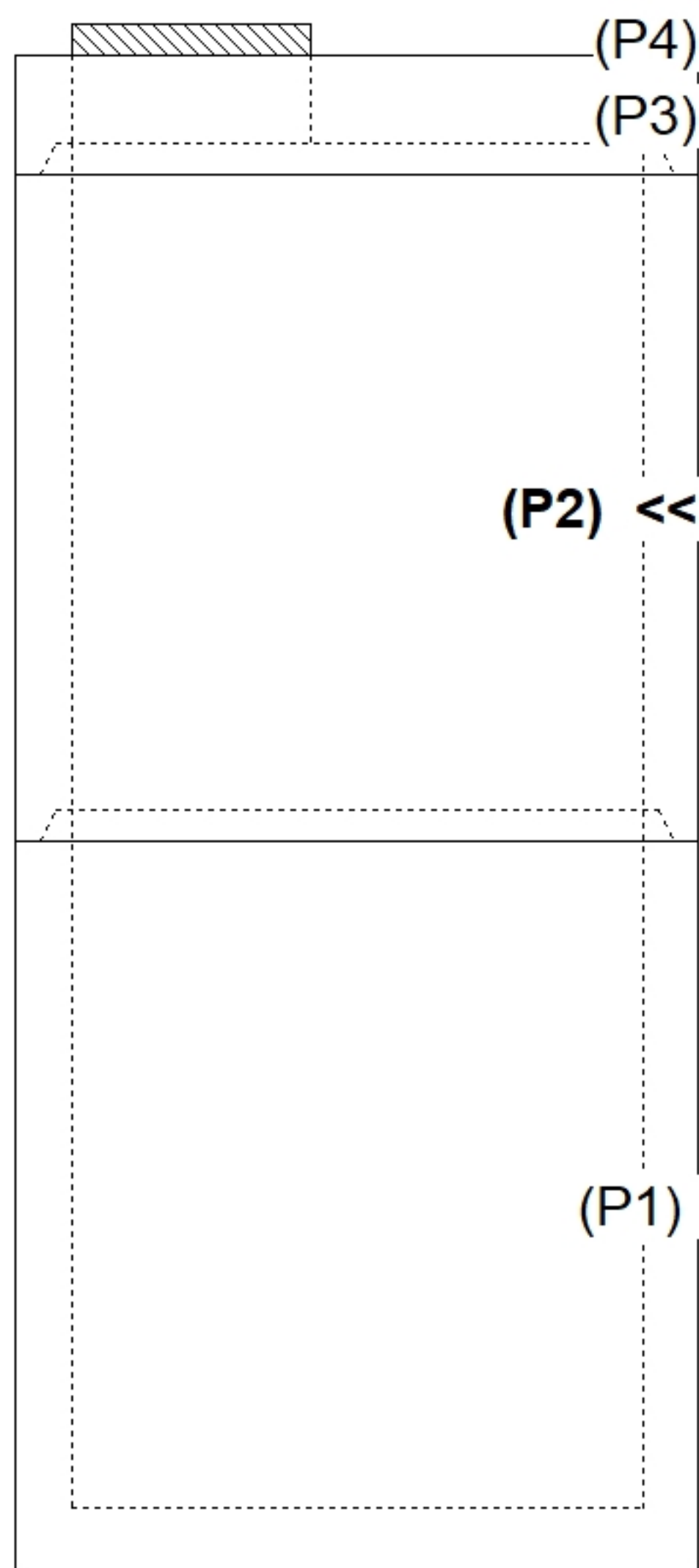

INSIDE WALL DIMENSIONS

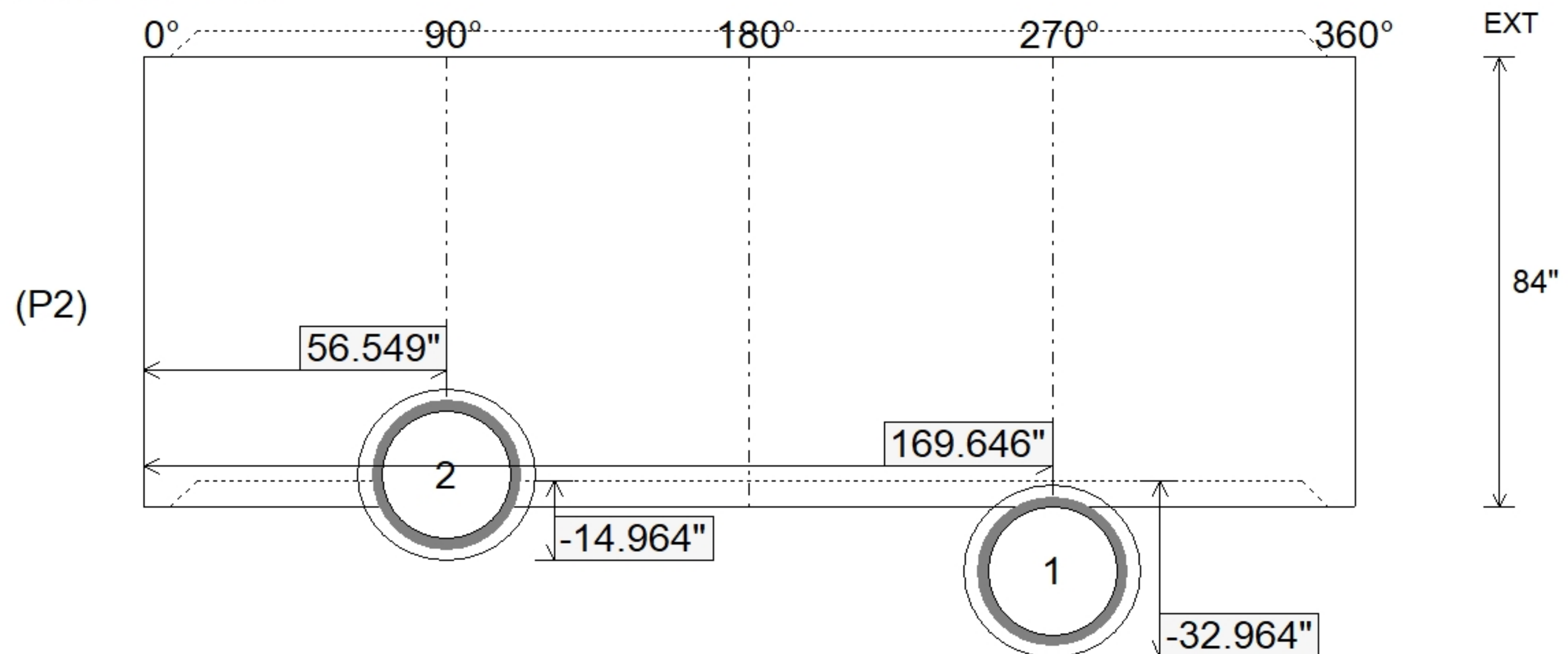

Coating (Int):	Seam Up: Tongue Seam Dn: Groove	Wall Thickness: 7" Floor Height: 0"	Height (Int): 84" Height (Ext): 84"
Coating (Ext):			Weight (Net): 11853 lb Volume (Net): 3.03cu.yd