

**PLAN VIEW**  
INTERNALS NOT SHOWN

15-CS-4

ICAST to fully pre-assemble internal materials prior to shipment

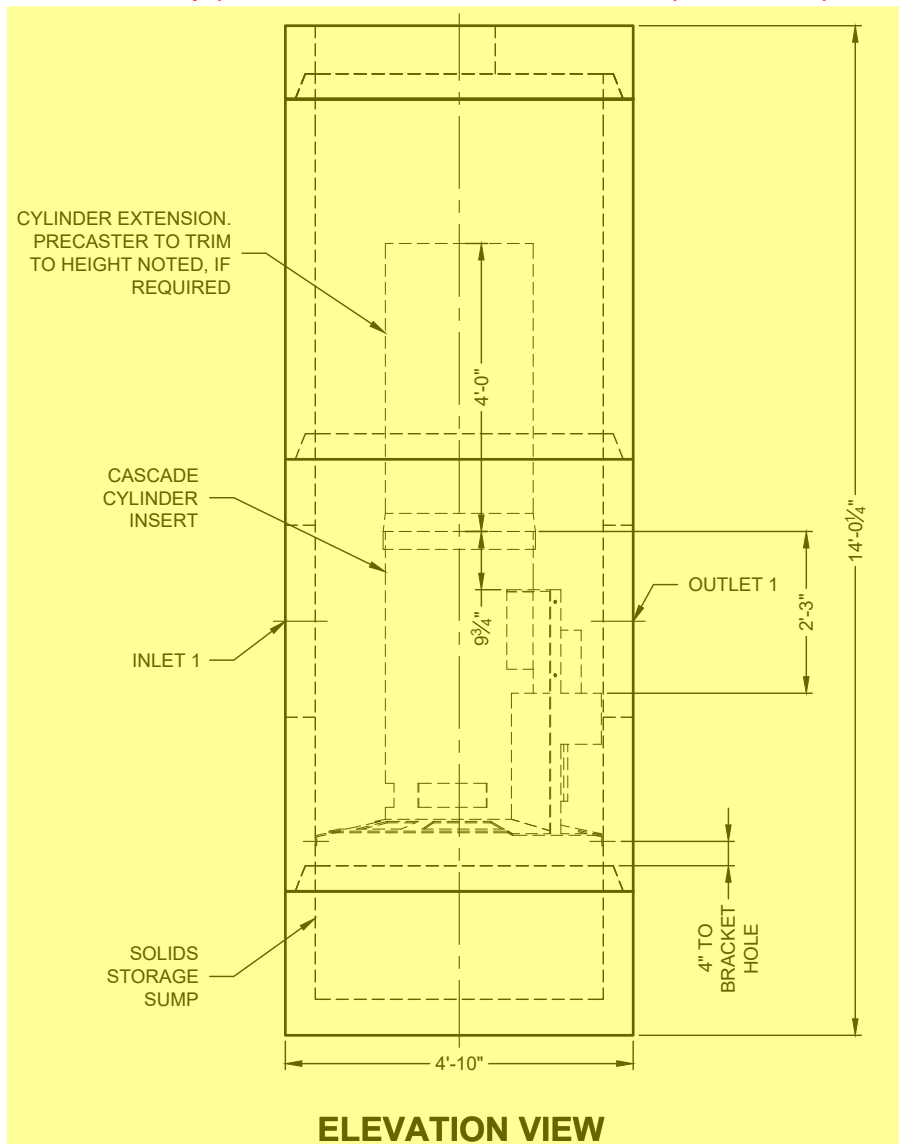

**ELEVATION VIEW**

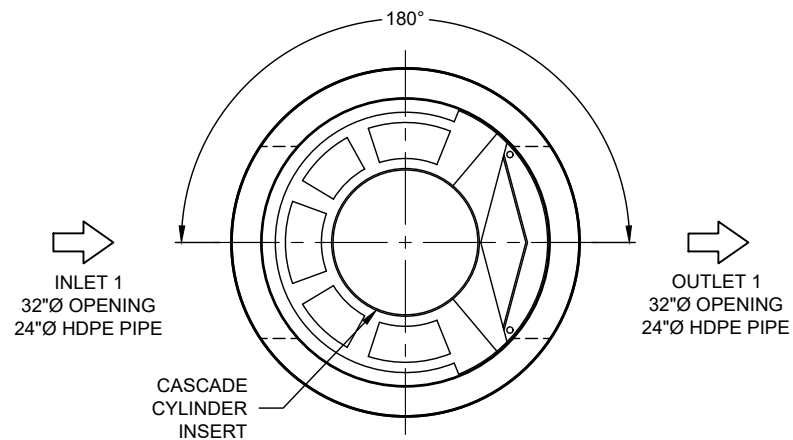

**PLAN VIEW FOR PIPE ORIENTATION**  
TOP SLAB NOT SHOWN

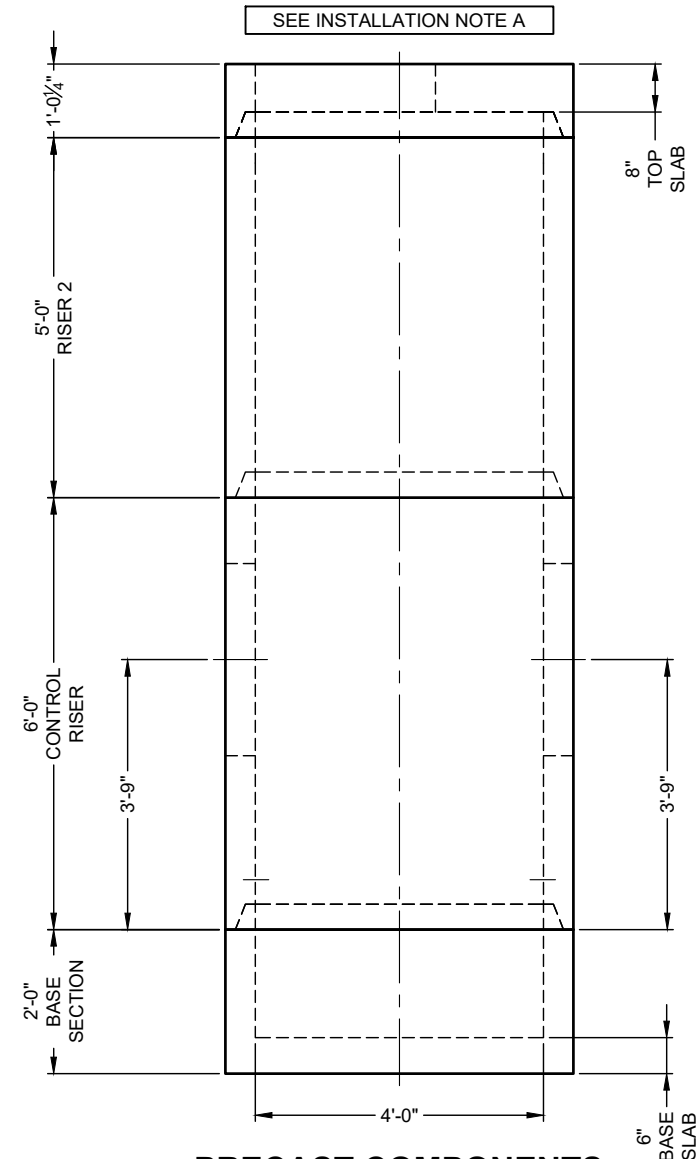

**PRECAST COMPONENTS**  
INTERNALS NOT SHOWN

ICAST  
5888 / 757440  
LAYOUT 1A  
6.58TS

CONTECH  
**FABRICATION**  
DRAWING

**MATERIAL LIST**

COUNT	DESCRIPTION	PART NUMBER	PROVIDED BY	INSTALLED BY
1	CS-4 CYLINDER INSERT, STD.	325-003949	CONTECH	PRECASTER
4	CS-4 ALUMINUM INSTALLATION BRACKETS	325-003956	CONTECH	PRECASTER
1	CS-4 HARDWARE KIT	325-003955	CONTECH	PRECASTER
1	CS-4 FIBERGLASS CYLINDER EXTENSION, 4 FT.	325-003960	CONTECH	CONTRACTOR
1	SEALANT FOR JOINTS		PRECASTER	CONTRACTOR
1	30"Ø X 4" FRAME AND COVER, EJ #41600483, OR EQUIV.	325-000332	CONTECH	CONTRACTOR

**GENERAL NOTES**

- DESIGN LOADING - AASHTO HS-20
- ALL PRECAST CONCRETE MANUFACTURED PARTS SHALL CONFORM TO ASTM C-478, WITH MINIMUM CONCRETE STRENGTH OF 4000 PSI AT 28 DAYS
- JOINT SEALANT SHALL CONFORM TO ASTM C-990 OR ASTM C-443
- GROUND WATER ELEVATION ASSUMED AT OUTLET INVERT
- MANUFACTURING TOLERANCE = +/- 1/2-INCH
- SOME HIDDEN LINES MAY BE OMITTED FOR CLARITY

**INSTALLATION NOTES**

- PRECASTER TO SHIP ACCESS CASTINGS WITH STRUCTURE
- REFER TO CONTECH ASSEMBLY INSTRUCTIONS FOR ADDITIONAL INFORMATION.
- PRECASTER TO INSTALL INTERNAL COMPONENTS PRIOR TO SHIPPING UNLESS INSTRUCTED OTHERWISE BY CONTECH
- PIPE OPENINGS SHALL BE STENCILED "INLET" OR "OUTLET" AS APPROPRIATE
- APPLYING ALIGNMENT MARKS ON ALL PIECES OF MULTIPLE PIECE ASSEMBLIES IS ENCOURAGED
- IF STRUCTURE IS DELIVERED IN MULTIPLE SECTIONS, EACH PIECE SHALL BE LABELED WITH THE CONTECH PROJECT NUMBER, SEQUENCE NUMBER AND SITE DESIGNATION

**SITE INFORMATION**

RIM ELEV. = 507.56+/-  
TOP OF STRUCTURE = 506.72  
INLET PIPE 1 INVERT ELEV. = 497.45  
INLET PIPE 1 DIAMETER AND MATERIAL = 24"Ø HDPE  
OUTLET PIPE INVERT ELEV. = 497.45  
OUTLET PIPE DIAMETER AND MATERIAL = 24"Ø HDPE  
OUTSIDE BOTTOM OF STRUCTURE ELEV. = 492.70

**STRUCTURE WEIGHT**

APPROXIMATE HEAVIEST PICK = 5000 LBS.  
STRUCTURE IS DELIVERED IN 4 PIECES

TOP SLAB = 2000 LBS.  
RISER 2 = 4500 LBS. LBS.  
CONTROL RISER = 5000 LBS.  
BASE SECTION = 3000 LBS.

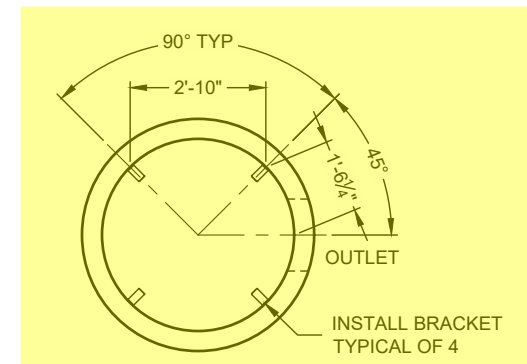

**SUPPORT BRACKET LAYOUT PLAN VIEW**

The design and information shown on this drawing is the property of CONTECH Construction Products, Inc. or one of its affiliated companies ("CONTECH"). Neither this drawing, nor any part thereof, may be used, reproduced, or transmitted in any form or by any means, electronic or mechanical, including photocopying, recording, or by any information storage and retrieval system, without the prior written consent of CONTECH. Failure to comply with these terms and conditions shall constitute a breach of contract and CONTECH expressly disclaims any liability or responsibility for such use.

If discrepancies between the supplied information upon which the drawing is based and actual field conditions are encountered as site work progresses, these are to be resolved by the contractor. CONTECH is not responsible for re-evaluation of the design. CONTECH accepts no liability for designs based on missing, incomplete or inaccurate information supplied by others.

MARK	DATE	REVISION DESCRIPTION	BY

CS-4 - 869435-015  
GARRISON GARDENS (10.15.25)  
BOWLING GREEN, KY  
SITE DESIGNATION: WQS 2-1

**CONTECH**  
ENGINEERED SOLUTIONS LLC  
A CONTECH COMPANY

810 Centre Pointe Dr., Suite 400, West Chester, OH 45380  
800.338.1122 513.645.7000 513.645.7803 FAX

**CASCADE separator**  
FOR PATENT INFORMATION, GO TO www.contech.com/IP

DATE:	03/27/26		
DESIGNED:	MDB	DRAWN:	JAVG/LRP
CHECKED:	MDB	APPROVED:	MDB
PROJECT No.:	869435	SEQUENCE No.:	015
SHEET:	1	OF	1

# 1810B4 V1600-4 Assembly

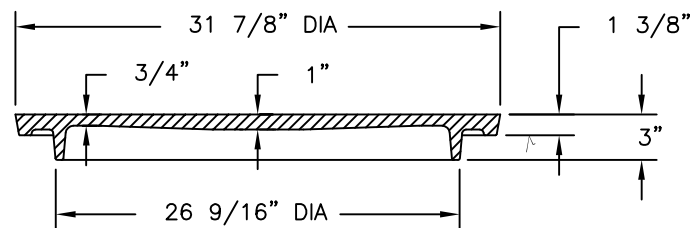
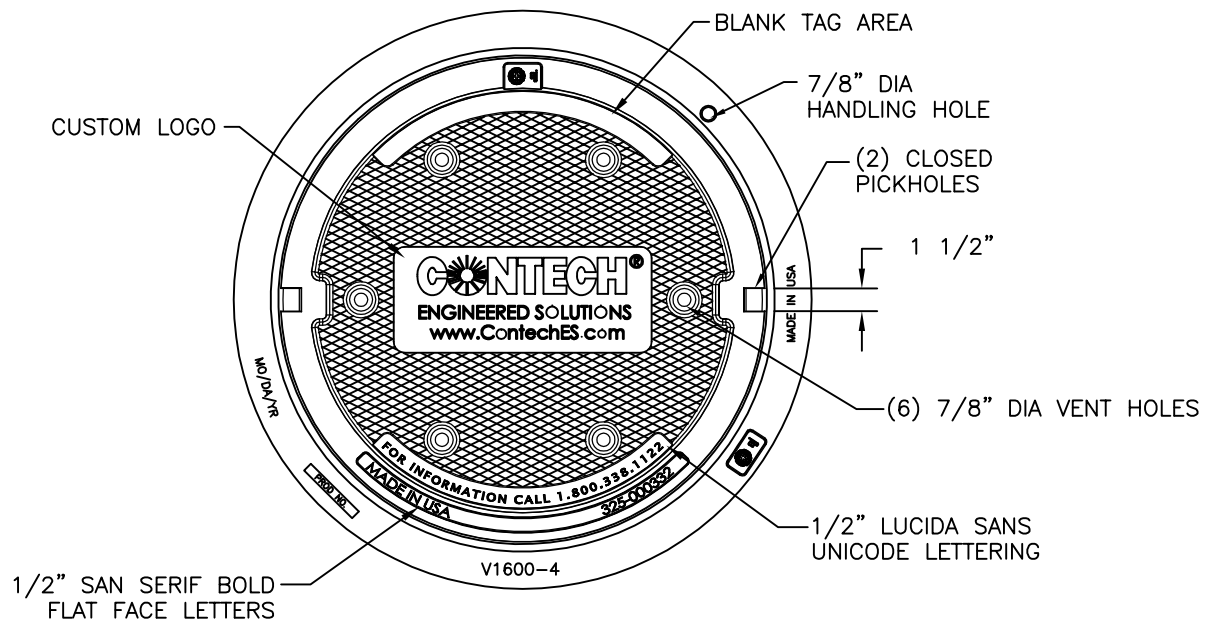

**COVER SECTION**

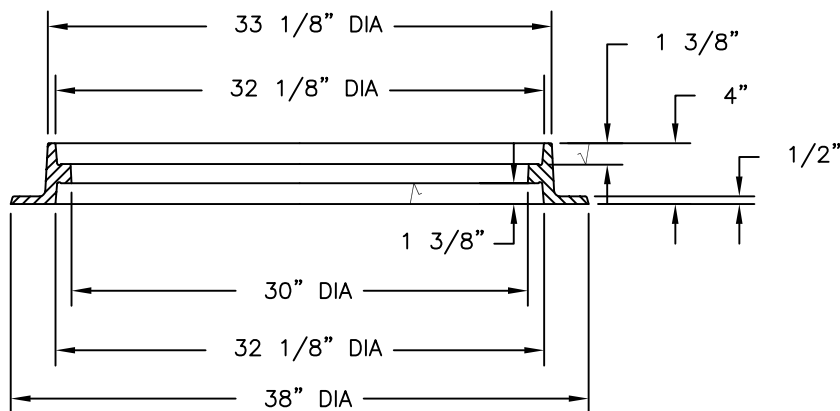

**FRAME SECTION**

**Product Number**  
41600483

**Design Features**

- Materials
  - Cover  
Gray Iron (CL35B)
  - Frame  
Gray Iron (CL35B)

- Design Load  
Heavy Duty
- Open Area  
n/a
- Coating  
Undipped
- √ Designates Machined Surface

**Certification**

- ASTM A48
- Country of Origin: USA

**Major Components**

00180783  
41600410

**Drawing Revision**

05/09/2007 Designer: SMH  
6/26/2017 Revised By: DAE

**Disclaimer**

Weights (lbs./kg) dimensions (inches/mm) and drawings provided for your guidance. We reserve the right to modify specifications without prior notice.

CONFIDENTIAL: This drawing is the property of EJ GROUP, Inc., and embodies confidential information, registered marks, patents, trade secret information, and/or know how that is the property of EJ GROUP, Inc. Copyright © 2012 EJ GROUP, Inc. All rights reserved.

**Contact**

800 626 4653  
ejco.com

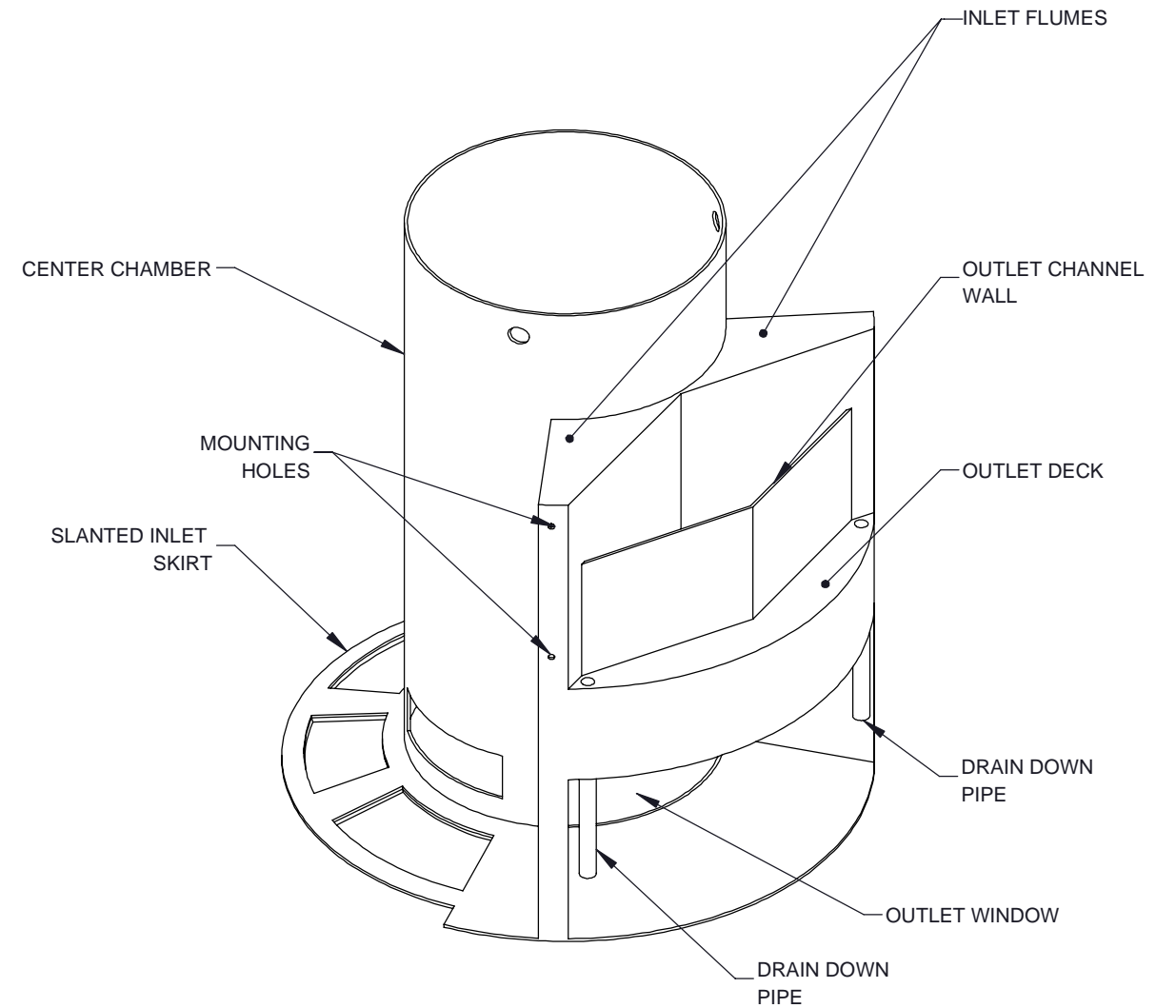
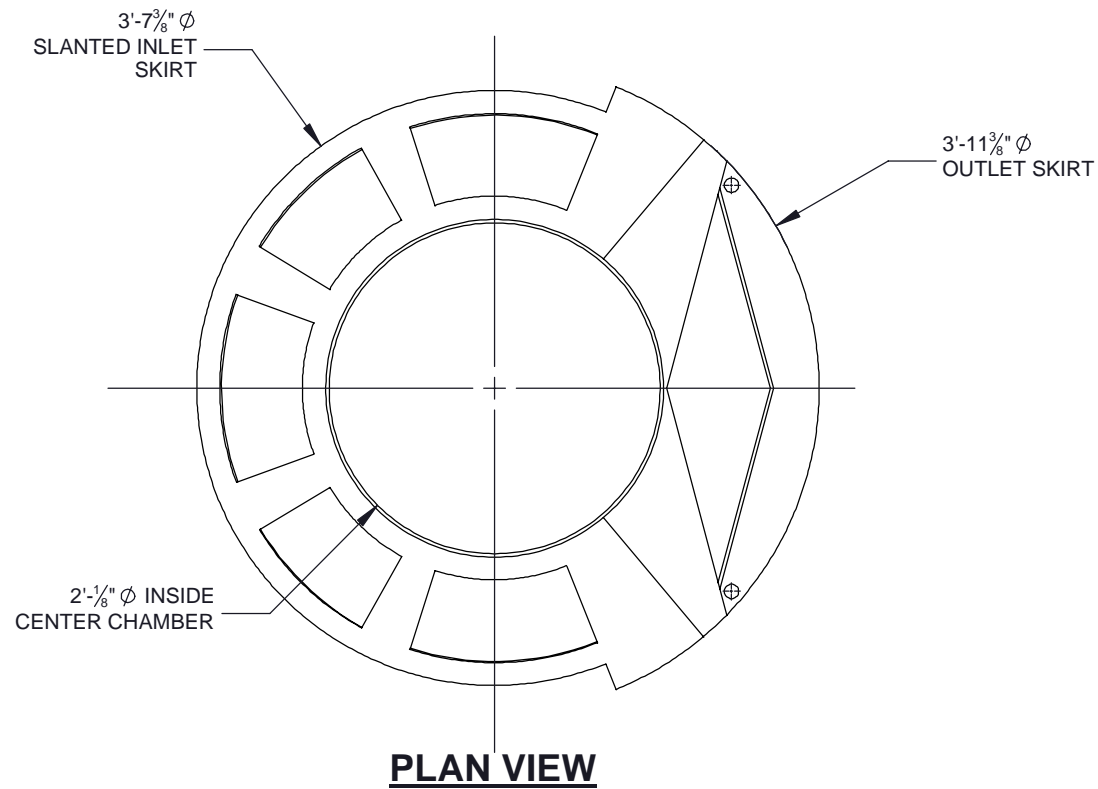

NOTES:  
1. SEE CASCADE SEPARATOR INSTALLATION GUIDE FOR ADDITIONAL INFORMATION

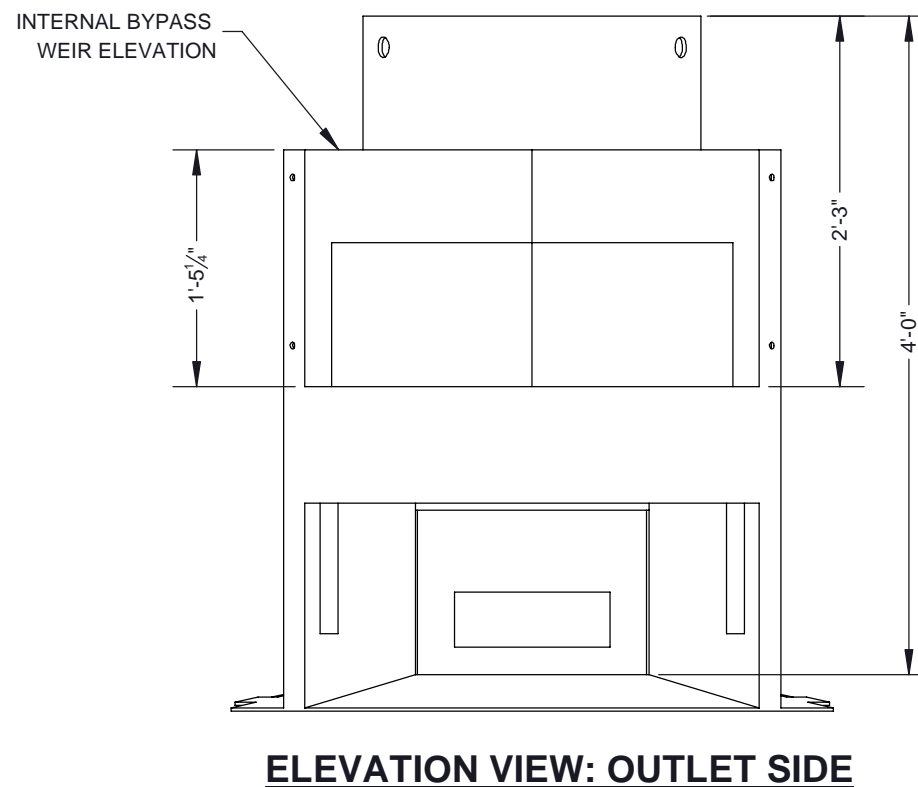
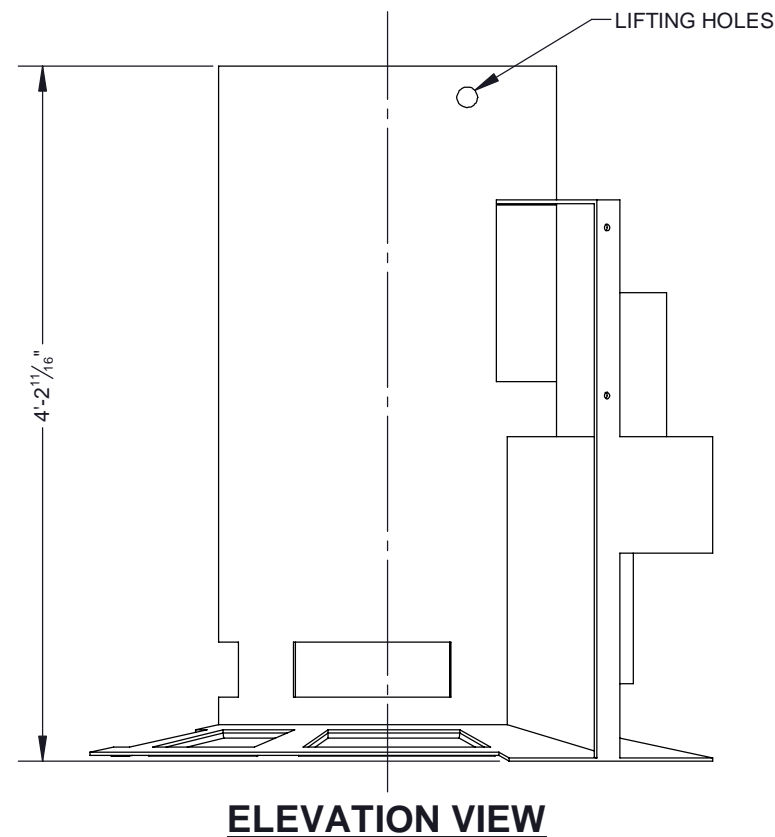

The design and information shown on this drawing is provided as a service to the project owner, engineer and contractor by Contech Engineered Solutions LLC, or one of its affiliated companies ("Contech"). Neither this drawing, nor any part thereof, may be used, reproduced or modified in any manner without the prior written consent of Contech. Failure to comply is done at the user's own risk and Contech expressly disclaims any liability or responsibility for such use.

If discrepancies between the supplied information upon which the drawing is based and actual field conditions are encountered as site work progresses, these discrepancies must be reported to Contech immediately for re-evaluation of the design. Contech accepts no liability for designs based on missing, incomplete or inaccurate information supplied by others.

**CASCADE**  
separator™

**CONTECH**  
ENGINEERED SOLUTIONS LLC

www.ContechES.com  
9025 Centre Pointe Dr., Suite 400, West Chester, OH 45069  
800-338-1122 513-645-7000 513-645-7993 FAX

REFERENCE DETAIL  
INTERNALS CS-4  
CASCADE SEPARATOR

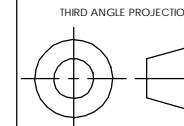

UNLESS OTHERWISE SPECIFIED  
DIMENSIONS ARE IN INCHES

TOLERANCES:  
FRACTIONAL ± 1/16  
ANGLES ± 1 DEGREE  
TWO PLACE DECIMAL ± 0.06  
THREE PLACE DECIMAL ± 0.030

PART NUMBER: 325-003949		
APPROVED BY: M. BROOKS	DRAWN BY: M. BROOKS	
APPROVED BY DATE: 2021.10.21	DRAWN BY DATE: 2021.09.14	REV: B
SCALE: N/A	SHEET 1 OF 1	

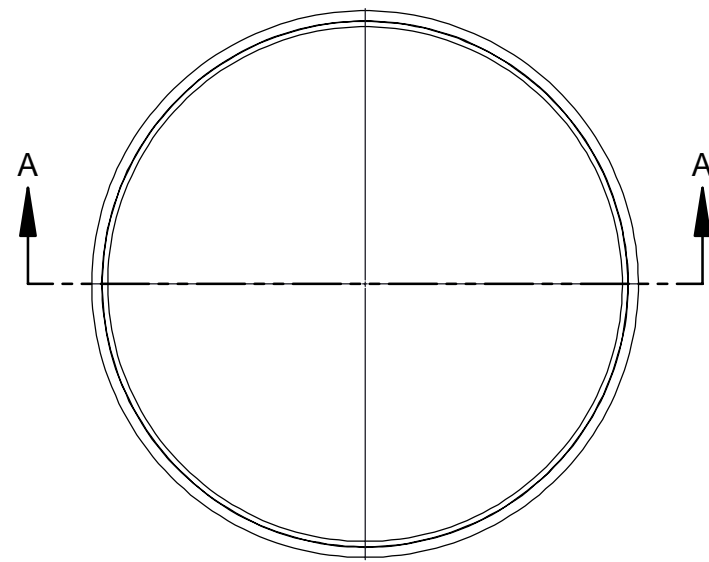

**PLAN VIEW**

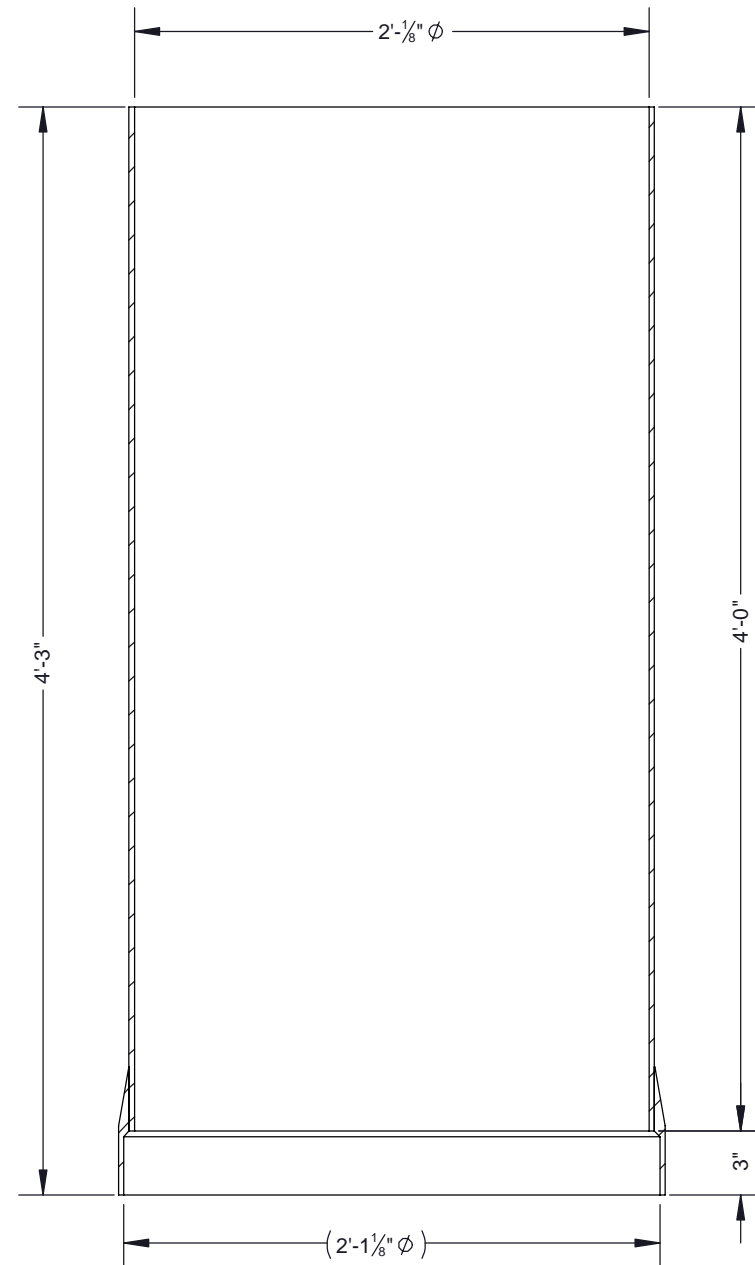

**SECTION A-A**

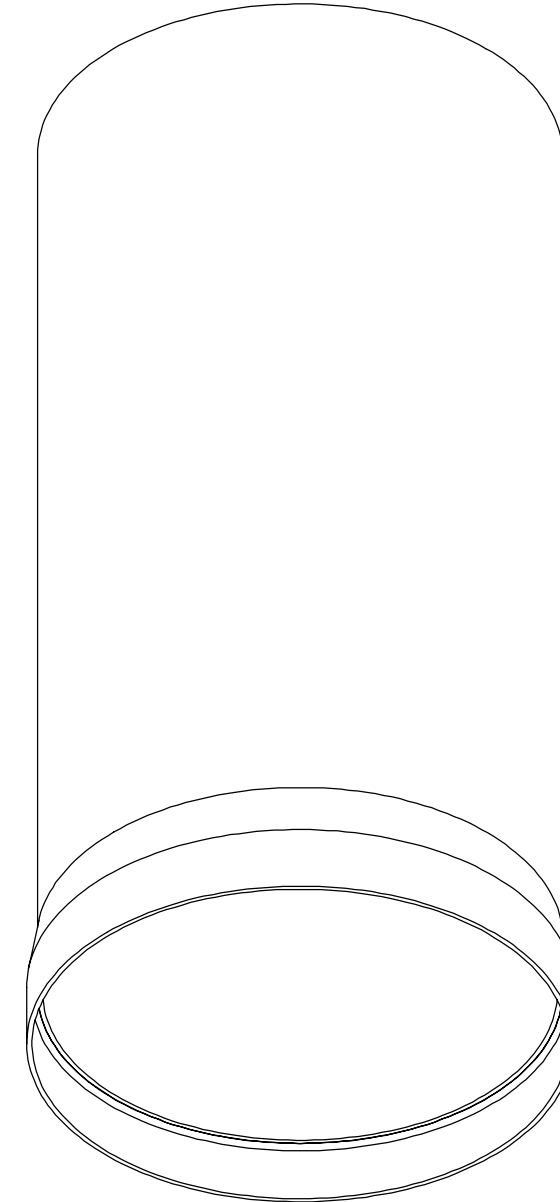

**ISOMETRIC VIEW**

NOTES:

1. SEE SITE SPECIFIC DRAWINGS FOR REQUIRED CYLINDER EXTENSION HEIGHT
2. SEE CYLINDER EXTENSION INSTALLATION GUIDE FOR ADDITIONAL INFORMATION

The design and information shown on this drawing is provided as a service to the project owner, engineer and contractor by Contech Engineered Solutions LLC, or one of its affiliated companies ("Contech"). Neither this drawing, nor any part thereof, may be used, reproduced or modified in any manner without the prior written consent of Contech. Failure to comply is done at the user's own risk and Contech expressly disclaims any liability or responsibility for such use.

If discrepancies between the supplied information upon which the drawing is based and actual field conditions are encountered as site work progresses, these discrepancies must be reported to Contech immediately for re-evaluation of the design. Contech accepts no liability for designs based on missing, incomplete or inaccurate information supplied by others.

**CASCADE**  
separator™

**CONTECH**  
ENGINEERED SOLUTIONS LLC  
www.ContechES.com

9025 Centre Pointe Dr., Suite 400, West Chester, OH 45069  
800-338-1122 513-645-7000 513-645-7993 FAX

REFERENCE DETAIL  
4 FT CYLINDER EXTENSION CS-4  
CASCADE SEPARATOR

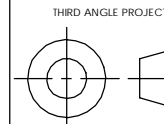

THIRD ANGLE PROJECTION  
UNLESS OTHERWISE SPECIFIED  
DIMENSIONS ARE IN INCHES

TOLERANCES:  
FRACTIONAL ± 1/16  
ANGLES ± 1 DEGREE  
TWO PLACE DECIMAL ± 0.06  
THREE PLACE DECIMAL ± 0.030

PART NUMBER: <b>325-003960</b>	
APPROVED BY: M. BROOKS	DRAWN BY: J. BELL
APPROVED BY DATE: 2022.02.14	DRAWN BY DATE: 2022.02.10
SCALE: N/A	REV: A
SHEET 1 OF 1	