

Job Name: 26-1882 - Fork River Commons
 Job Location: Millington, TN
 Contractor: Woods Constructions Services, Inc.

Plant: 100
 4/30/2026 12:37:40 PM

Tech: Jared - A
 PC: T. Lewis



Structure ID: MH-5 ST-MH

P2 MH048CN36

ECC CONE w/ 24" HOLE F/G

- P3) 24" - CASTING HEIGHT - 7"
- P2) 48" - ECC CONE w/ 24" HOLE F/G - 36"
- P1) 48" - MH BASE (08"F) T/n - 60"
- 1) CASTING - JBS 1020 F/C DRAIN
- 1) 48" - Conseal CS-102 1.00"
- 2) Hole - 30
- 8) MH Step ML-10-TDS-NCR - 10"

0 lb
 3000 lb
 5333 lb
 250 lb
 0 lb
 0 lb
 0 lb

 8583 lb

Structure Total:

- Structure Notes:
1. PER ASTM C-478 SPECIFICATIONS
 2. CONCRETE: 4,000 PSI AT 28 DAYS
 3. REINFORCEMENT: PER ASTM A615
 4. STEPS REQUIRED
 5. JBS 1020 FRAME & COVER "DRAIN" SUPPLIED BY ICAST

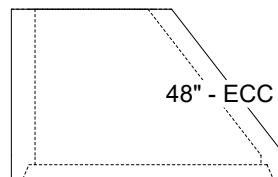
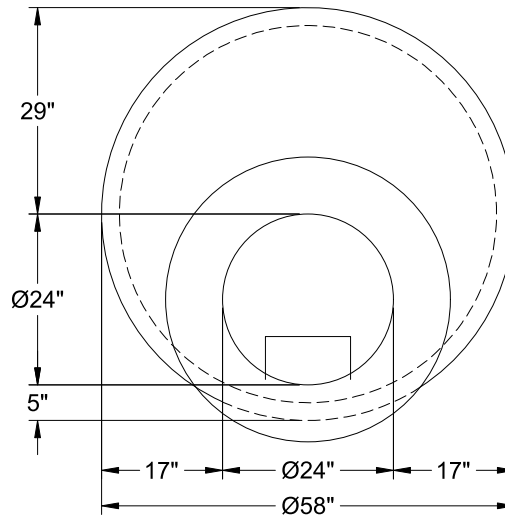

Coating (Int):
 Coating (Ext):

Seam Up: Flat
 Seam Dn: Groove

Wall Thickness: 5"

Height (Ext): 36"

Weight (Net): 3000 lb
 Volume (Net): 0.5cu.yd