

Job Name: 26-1882 - Fork River Commons
 Job Location: Millington, TN
 Contractor: Woods Constructions Services, Inc.

Plant: 100

4/30/2026 12:37:05 PM

Tech: Jared - A

PC: T. Lewis



Structure ID: MH-2 ST-MH

P1 MH048BA42

MH BASE (08"F) T/n

- P4) 24" - CASTING HEIGHT - 7"
- P3) 48" - ECC CONE w/ 24" HOLE F/G - 36"
- P2) 48" - MH RISER T/G - 48"
- P1) 48" - MH BASE (08"F) T/n - 42"
- 1) CASTING - JBS 1020 F/C DRAIN
- 2) 48" - Conseal CS-102 1.00"
- 2) Hole - 30
- 10) MH Step ML-10-TDS-NCR - 10"

0 lb
 3000 lb
 3353 lb
 4076 lb
 250 lb
 0 lb
 0 lb
 0 lb

 Structure Total: 10679 lb

- Structure Notes:**
1. PER ASTM C-478 SPECIFICATIONS
 2. CONCRETE: 4,000 PSI AT 28 DAYS
 3. REINFORCEMENT: PER ASTM A615
 4. NO STORM INVERT
 5. STEPS AT 264 DEGREES
 6. JBS 1020 FRAME & COVER "DRAIN" SUPPLIED BY ICAST

Rim: 284.17' Rim to Invert: 11.09' Slack: 1.98" Sump: 1.9" Step Position: 264°

Position	Elev	Angle	Ext. (cw)	Pipe	Pipe OD	Connector	Hole	Horz Size	Up ()	Offset
Invert 1	273.08'	0°	0"	24" HDPE	27.8"	Hole 30	30"	32.406"	0"	0"
Invert 2	273.08'	168°	85"	24" HDPE	27.8"	Hole 30	30"	32.406"	0"	0"
Invert 3										
Invert 4										
Invert 5										
Invert 6										
Invert 7										
Invert 8										

RIGHT-SIDE UP VIEW (int. dimensions)

UPSIDE-DOWN VIEW (int. dimensions)

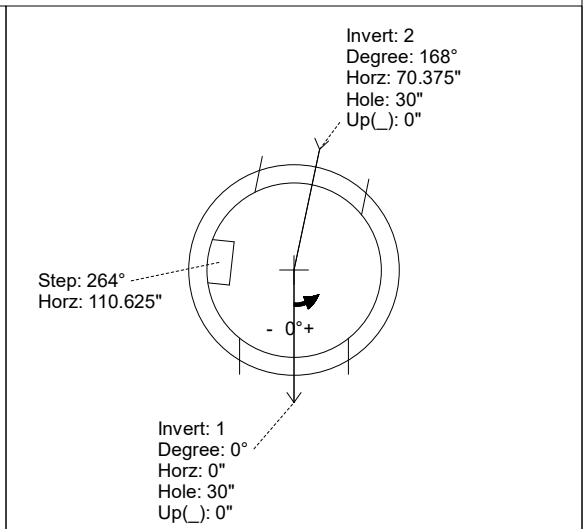
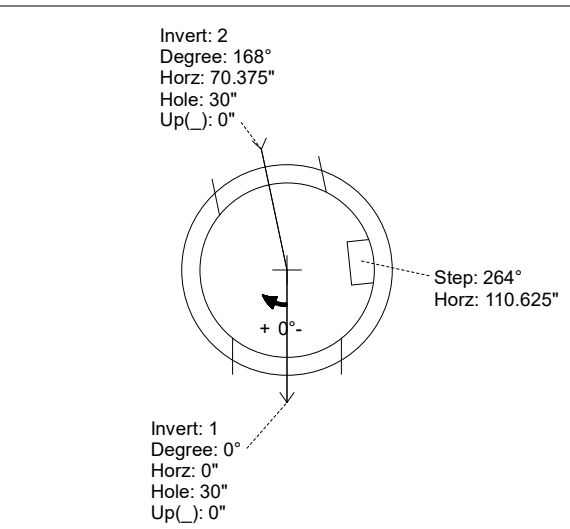
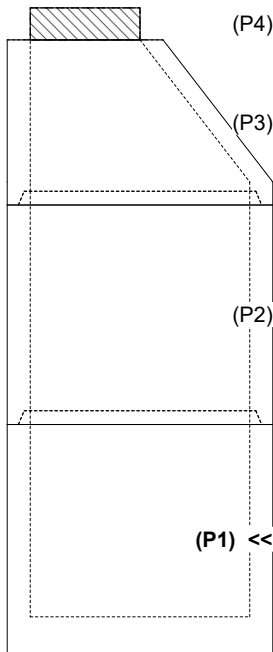

INSIDE WALL DIMENSIONS

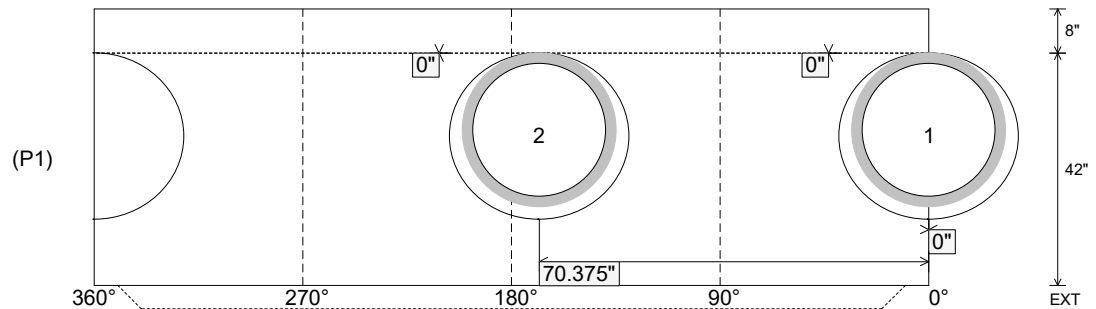

Coating (Int):
 Coating (Ext):

Seam Up: Tongue
 Seam Dn: n/a

Wall Thickness: 5"
 Floor Height: 8"

Height (Int): 42"
 Height (Ext): 50"

Weight (Net): 4076 lb
 Volume (Net): 1.04cu.yd