

Job Name: 26-1882 - Fork River Commons  
 Job Location: Millington, TN  
 Contractor: Woods Constructions Services, Inc.

Plant: 100

4/30/2026 12:37:04 PM

Tech: Jared - A

PC: T. Lewis



**Structure ID: MH-1 ST-MH**

**P1 MH048BA36**

**MH BASE (08"F) T/n**

- P5) 24" - CASTING HEIGHT - 7"
- P4) 24" - GRADE RING F/F - 4"
- P3) 48" - ECC CONE w/ 24" HOLE F/G - 30"
- P2) 48" - MH RISER T/G - 60"
- P1) 48" - MH BASE (08"F) T/n - 36"
- 1) CASTING - JBS 1020 F/C DRAIN
- 2) 48" - Conseal CS-102 1.00"
- 2) Hole - 30
- 11) MH Step ML-10-TDS-NCR - 10"

0 lb  
 270 lb  
 2050 lb  
 4192 lb  
 3656 lb  
 250 lb  
 0 lb  
 0 lb  
 0 lb  
 0 lb  
 Structure Total: 10418 lb

- Structure Notes:**
1. PER ASTM C-478 SPECIFICATIONS
  2. CONCRETE: 4,000 PSI AT 28 DAYS
  3. REINFORCEMENT: PER ASTM A615
  4. NO STORM INVERT
  5. STEPS AT 233 DEGREES
  6. JBS 1020 FRAME & COVER "DRAIN" SUPPLIED BY ICAST

Rim: 284.22' Rim to Invert: 11.37' Slack: 1.34" Sump: 1.9" Step Position: 233°

Position	Elev	Angle	Ext. (cw)	Pipe	Pipe OD	Connector	Hole	Horz Size	Up ( )	Offset
Invert 1	272.85'	0°	0"	24" HDPE	27.8"	Hole 30	30"	32.406"	0"	0"
Invert 2	272.85'	106°	53.625"	24" HDPE	27.8"	Hole 30	30"	32.406"	0"	0"
Invert 3										
Invert 4										
Invert 5										
Invert 6										
Invert 7										
Invert 8										

RIGHT-SIDE UP VIEW (int. dimensions)

UPSIDE-DOWN VIEW (int. dimenions)

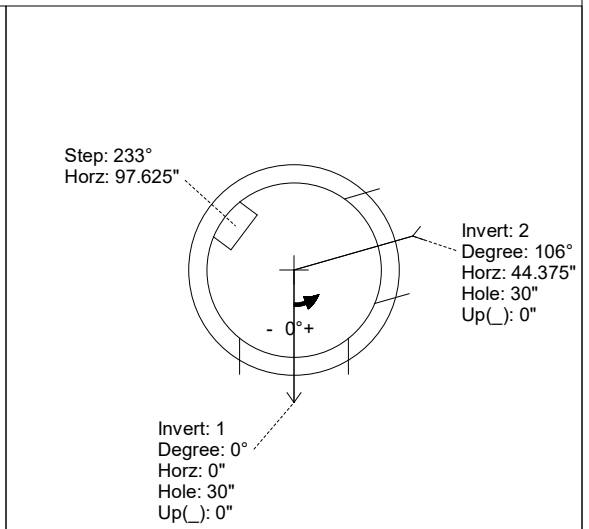
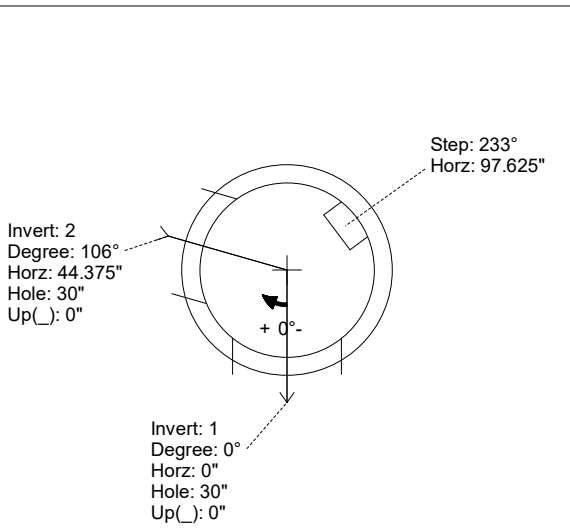
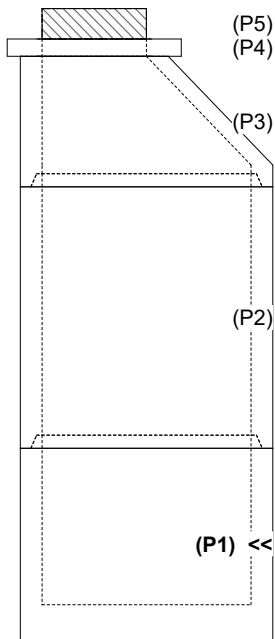

INSIDE WALL DIMENSIONS

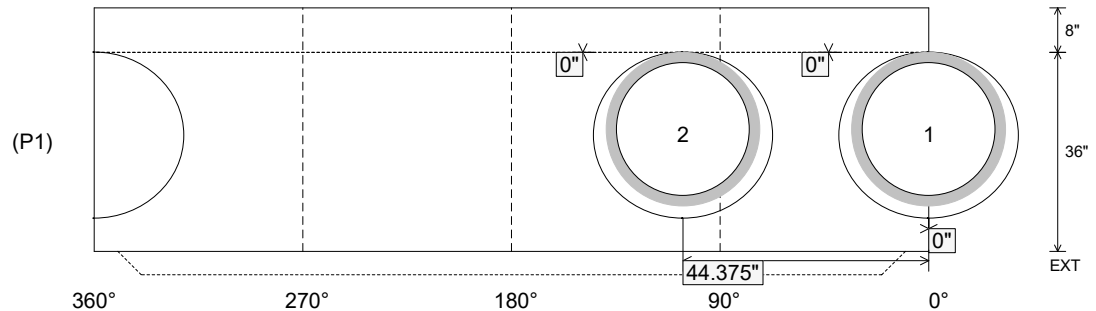

Coating (Int):  
 Coating (Ext):

Seam Up: Tongue  
 Seam Dn: n/a

Wall Thickness: 5"  
 Floor Height: 8"

Height (Int): 36"  
 Height (Ext): 44"

Weight (Net): 3656 lb  
 Volume (Net): 0.93cu.yd