

Job Name: 26-1648 837557 71 Trade Center
 Job Location: La Grange, KY
 Contractor: Contech Engineering Solutions

Plant: Beaver Dam
 3/19/2026 2:02:37 PM

Tech: S. Felletter
 PC: T. Sekula



Structure ID: 15-CS-8

P4 MH096LD17SP

MH FLAT TOP SPEC. (2 - 24"Ø HOLES) F/G

- P5) 24" - CASTING HEIGHT - 4"
- P4) 96" - MH FLAT TOP SPEC. (2 - 24"Ø HOLES) F/G - 17"
- P3) 96" - MH RISER T/G - 60"
- P2) 96" - MH RISER T/G - 96"
- P1) 96" - MH MONOBASE 13F, Custom Ht T/n - 24"
- 1) CVSTENCILING
- 1) ASSEMBLY REQUIRED
- 3) 96" - Conseal CS-102 1.00"
- 2) Hole - 24"

0 lb
 10015 lb
 14947 lb
 23226 lb
 17113 lb
 0 lb
 0 lb
 0 lb
 0 lb

 Structure Total: 65301 lb

Structure Notes:
 4" CASTING BY OTHERS

 LIFTING ANCHORS TO BE INSTALLED
 ON THE OUTSIDE OF THE STRUCTURE

 ICAST TO INSTALL THE INTERNALS

 CONTECH'S LOGO AS WELL AS THE
 INLET AND OUTLET MUST BE
 STENCILED ONTO THE STRUCTURE

GENERAL NOTES:

1. MANUFACTURED TO ASTM C-478 (LATEST REVISION).
2. CONCRETE 5,000 PSI AT 28 DAYS.
3. WEIGHT: 10,015 LBS.
4. REINFORCING: TOP MAT: #4 BAR @ 18" C/C E.W.
 BOTTOM MAT: #5 BAR @ 12" C/C E.W.
 PER ASTM A615 (GRADE 60)

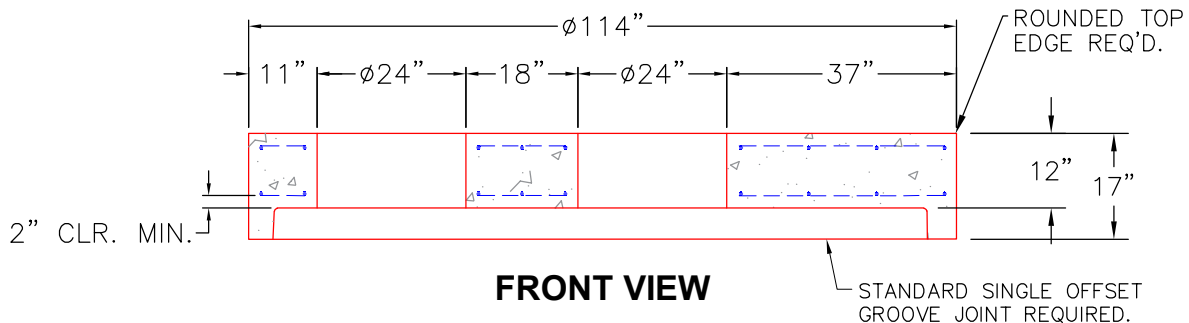
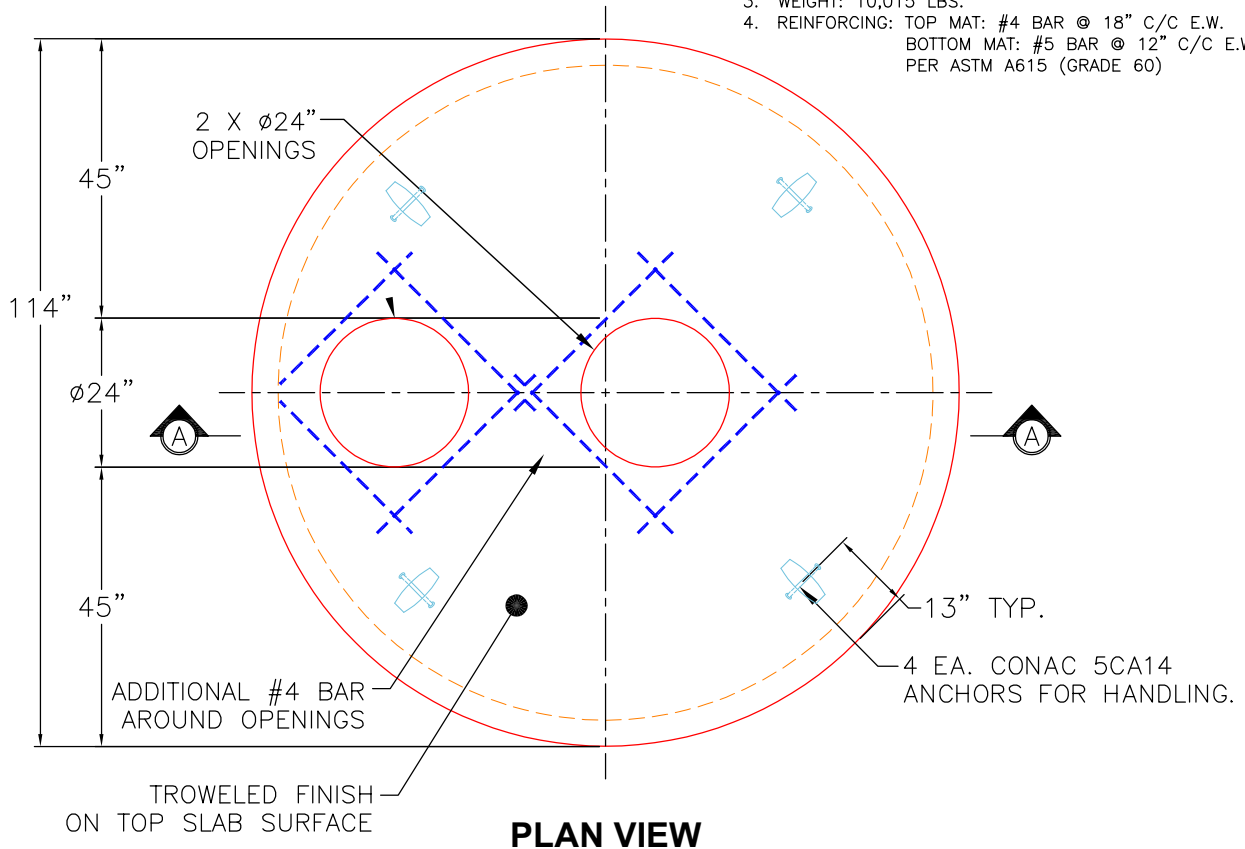

Coating (Int):
 Coating (Ext):

Seam Up: Flat
 Seam Dn: Groove

Wall Thickness: 9"

Height (Ext): 17"

Weight (Net): 10015 lb
 Volume (Net): 2.56cu.yd