

Structure ID: 15-CS-8

P2 MH096RS96

MH RISER T/G

P5) 24" - CASTING HEIGHT - 4" P4) 96" - MH FLAT TOP SPEC. (2 - 24"Ø HOLES) F/G - 17" P3) 96" - MH RISER T/G - 60" P2) 96" - MH RISER T/G - 96" P1) 96" - MH MONOBASE 13F, Custom Ht T/n - 24" 1) CVSTENCILING 1) ASSEMBLY REQUIRED 3) 96" - Conseal CS-102 1.00" 2) Hole - 24	0 lb 10015 lb 14947 lb 23226 lb 17113 lb 0 lb 0 lb 0 lb 0 lb 0 lb ----- Structure Total: 65301 lb
-------------------------------------------------------------------------------------------------------------------------------------------------------------------------------------------------------------------------------------------------------------------------------------------------------	------------------------------------------------------------------------------------------------------------------------------------

Structure Notes:
 4" CASTING BY OTHERS

LIFTING ANCHORS TO BE INSTALLED ON THE OUTSIDE OF THE STRUCTURE

ICAST TO INSTALL THE INTERNALS

CONTECH'S LOGO AS WELL AS THE INLET AND OUTLET MUST BE STENCILED ONTO THE STRUCTURE

Rim: 724.2' Rim to Invert: 10.2' Slack: 3.444" Sump: 82.044" Step Position:

Position	Elev	Angle	Ext. (cw)	Pipe	Pipe OD	Connector	Hole	Horz Size	Up ()	Offset
Invert 1	714'	270°	268.606"	18" HDPE	21.2"	Hole 24	24"	24.257"	50.044"	0"
Invert 2	714'	350°	348.193"	18" HDPE	21.2"	Hole 24	24"	24.257"	50.044"	0"
Invert 3										
Invert 4										
Invert 5										
Invert 6										
Invert 7										
Invert 8										

RIGHT-SIDE UP VIEW (int. dimensions)

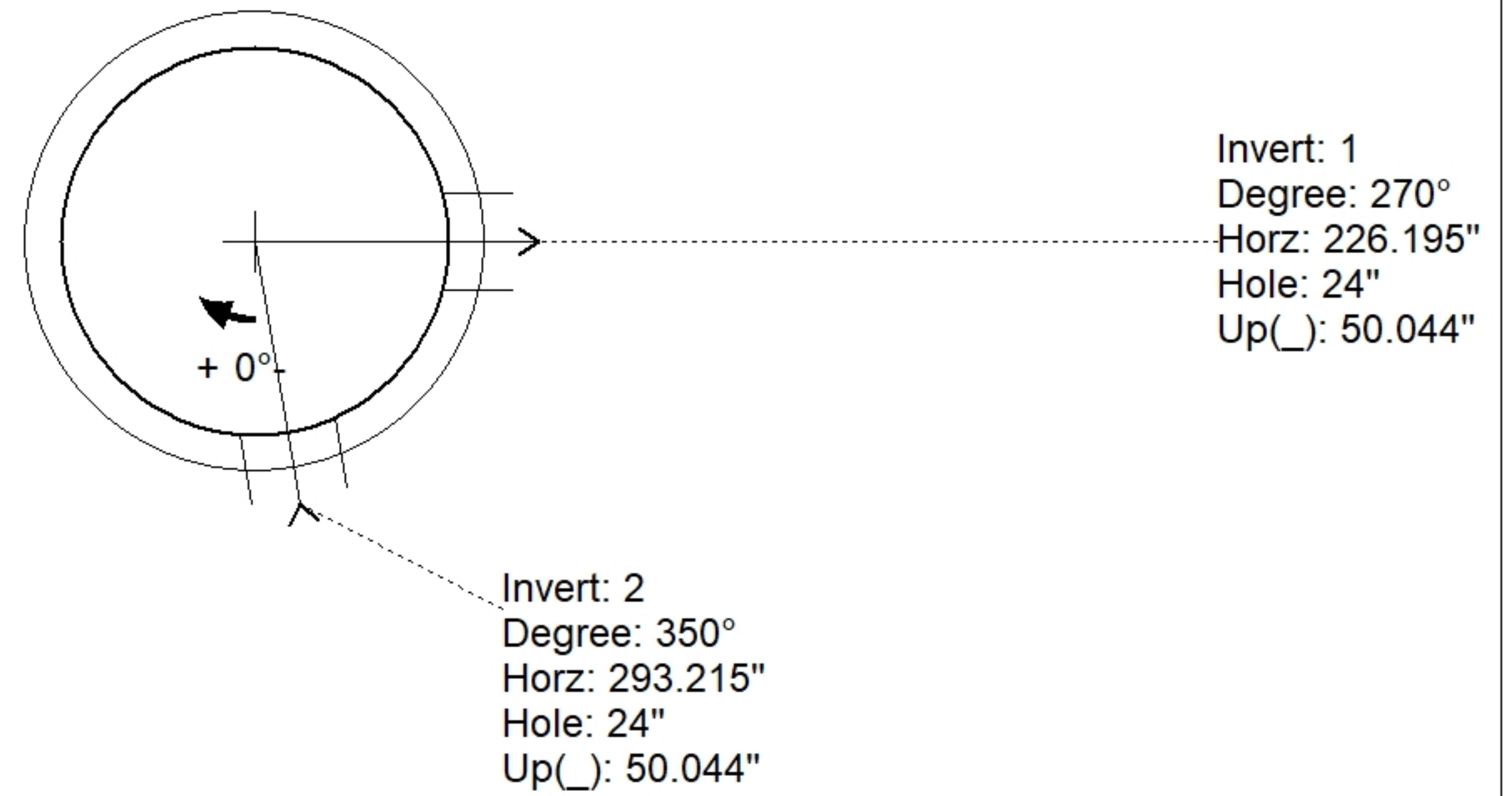
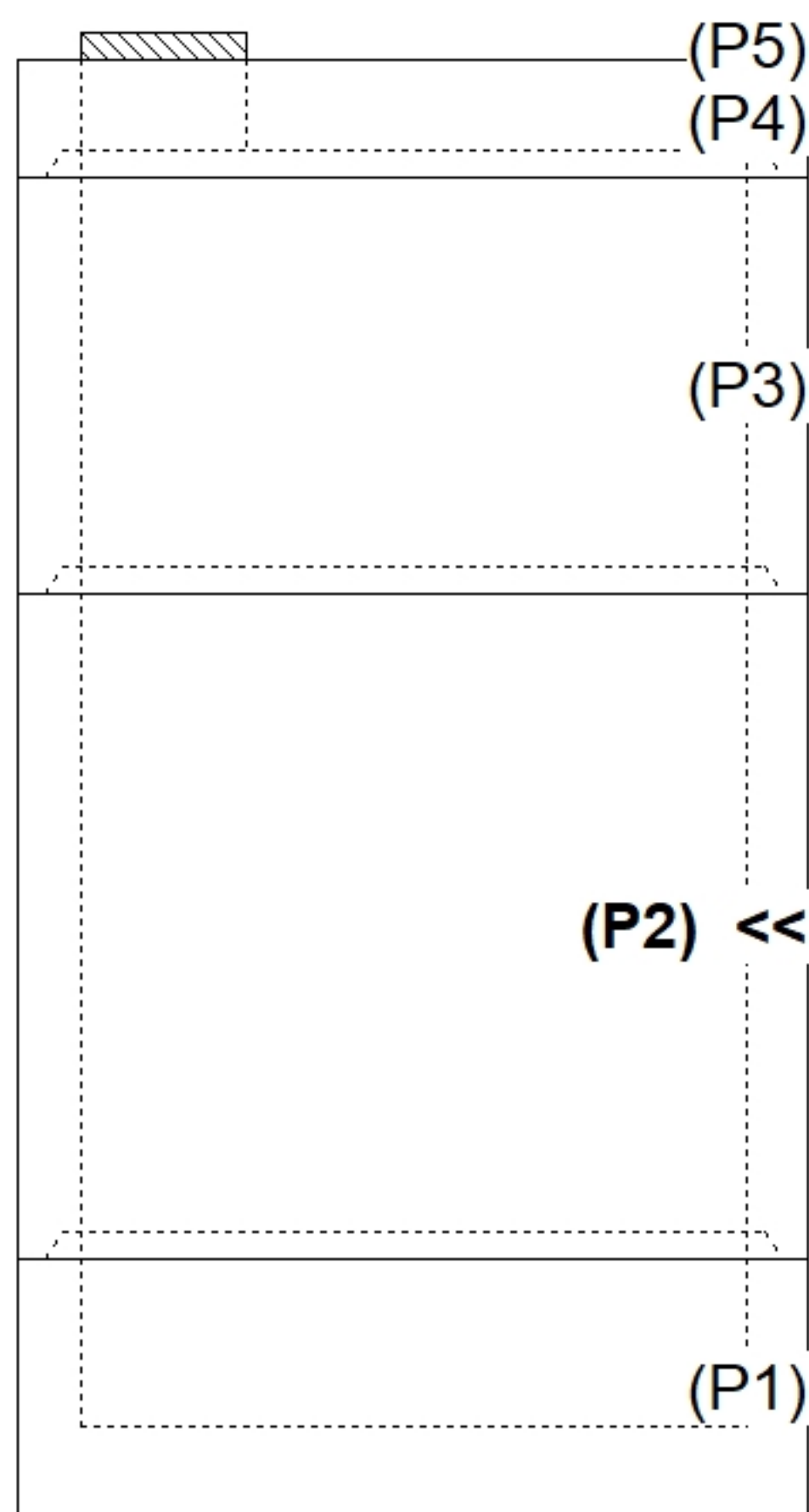

INSIDE WALL DIMENSIONS

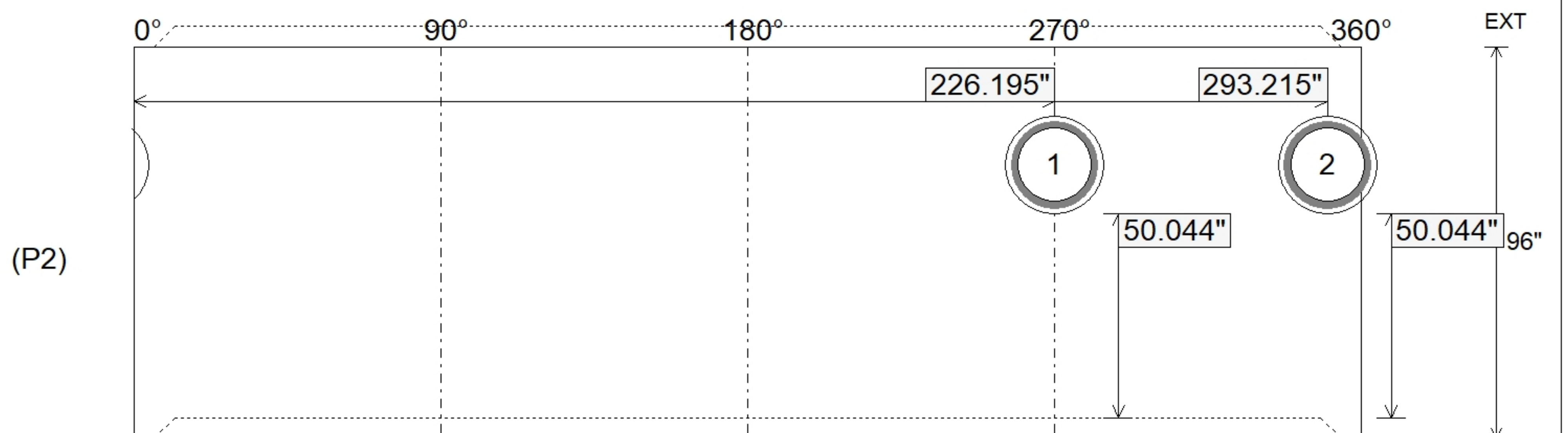

Coating (Int): Coating (Ext):	Seam Up: Tongue Seam Dn: Groove	Wall Thickness: 9" Floor Height: 0"	Height (Int): 96" Height (Ext): 96"	Weight (Net): 23226 lb Volume (Net): 5.93cu.yd
----------------------------------	------------------------------------	----------------------------------------	----------------------------------------	---------------------------------------------------