

Job Name: 26-1648 837557 71 Trade Center
 Job Location: La Grange, KY
 Contractor: Contech Engineering Solutions

Plant: Beaver Dam
 3/19/2026 2:02:19 PM

Tech: S. Felletter
 PC: T. Sekula



Structure ID: 15-CS-8

P1 MH096BAVF

MH MONOBASE 13F, Custom Ht T/n

- P5) 24" - CASTING HEIGHT - 4"
- P4) 96" - MH FLAT TOP SPEC. (2 - 24"Ø HOLES) F/G - 17"
- P3) 96" - MH RISER T/G - 60"
- P2) 96" - MH RISER T/G - 96"
- P1) 96" - MH MONOBASE 13F, Custom Ht T/n - 24"
- 1) CVSTENCILING
- 1) ASSEMBLY REQUIRED
- 3) 96" - Conseal CS-102 1.00"
- 2) Hole - 24

0 lb
 10015 lb
 14947 lb
 23226 lb
 17113 lb
 0 lb
 0 lb
 0 lb
 0 lb

 Structure Total: 65301 lb

Structure Notes:
 4" CASTING BY OTHERS

 LIFTING ANCHORS TO BE INSTALLED
 ON THE OUTSIDE OF THE STRUCTURE

 ICAST TO INSTALL THE INTERNALS

 CONTECH'S LOGO AS WELL AS THE
 INLET AND OUTLET MUST BE
 STENCILED ONTO THE STRUCTURE

Rim: 724.2' Rim to Invert: 10.2' Slack: 3.444" Sump: 82.044" Step Position:

GENERAL NOTES:

1. MANUFACTURED TO ASTM C-478 (LATEST REVISION).
2. CONCRETE 5,000 PSI AT 28 DAYS.
3. REINFORCING: WALLS - WWF AREA 0.24
 FLOOR - AREA 0.27 - #5 BAR @ 12" C/C TOP
 AND BOTTOM MAT.
4. WEIGHT: TOTAL - 17,113 LBS.
 FIRST POUR - 8,216 LBS
 SECOND POUR - 7,897 LBS
5. JOINT SEAL: CONCRETE SEALANTS INC. CS-102.
6. ICAST TO INSTALL INTERNALS
7. CONTECH'S LOGO AS WELL AS THE INLETS
 AND OUTLETS MUST BE STENCILED ONTO THE
 STRUCTURE.

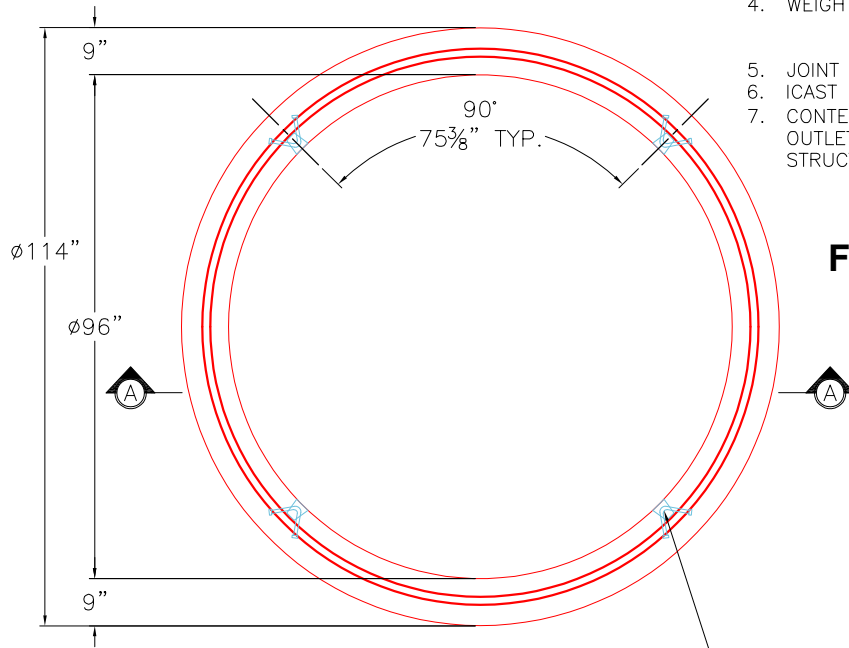

TOP VIEW

FIRST POUR DRAWING

4 EA. CONAC 6CA14
 ANCHORS REQUIRED
 FOR HANDLING.

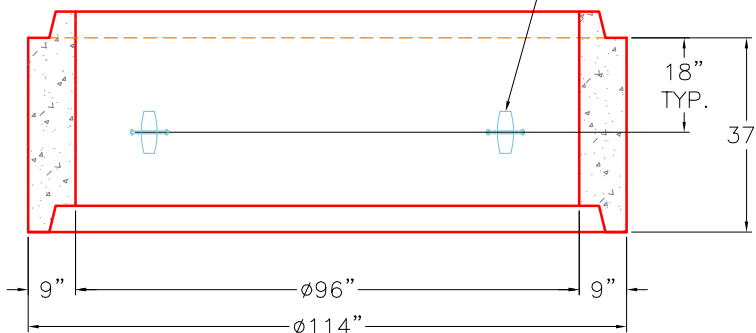

SECTION A-A

Coating (Int):
 Coating (Ext):

Seam Up: Tongue
 Seam Dn: n/a

Wall Thickness: 9"
 Floor Height: 13"

Height (Int): 24"
 Height (Ext): 37"

Weight (Net): 17113 lb
 Volume (Net): 4.37cu.yd

Job Name: 26-1648 837557 71 Trade Center
 Job Location: La Grange, KY
 Contractor: Contech Engineering Solutions

Plant: Beaver Dam
 3/19/2026 2:02:19 PM

Tech: S. Felletter
 PC: T. Sekula



Structure ID: 15-CS-8

P1 MH096BAVF

MH MONOBASE 13F, Custom Ht T/n

- P5) 24" - CASTING HEIGHT - 4"
- P4) 96" - MH FLAT TOP SPEC. (2 - 24"Ø HOLES) F/G - 17"
- P3) 96" - MH RISER T/G - 60"
- P2) 96" - MH RISER T/G - 96"
- P1) 96" - MH MONOBASE 13F, Custom Ht T/n - 24"
- 1) CVSTENCILING
- 1) ASSEMBLY REQUIRED
- 3) 96" - Conseal CS-102 1.00"
- 2) Hole - 24"

0 lb
 10015 lb
 14947 lb
 23226 lb
 17113 lb
 0 lb
 0 lb
 0 lb
 0 lb

 Structure Total: 65301 lb

Structure Notes:
 4" CASTING BY OTHERS
 LIFTING ANCHORS TO BE INSTALLED ON THE OUTSIDE OF THE STRUCTURE
 ICAST TO INSTALL THE INTERNALS
 CONTECH'S LOGO AS WELL AS THE INLET AND OUTLET MUST BE STENCILED ONTO THE STRUCTURE

Rim: 724.2' Rim to Invert: 10.2' Slack: 3.444" Sump: 82.044" Step Position:

GENERAL NOTES:

1. MANUFACTURED TO ASTM C-478 (LATEST REVISION).
2. CONCRETE 5,000 PSI AT 28 DAYS.
3. REINFORCING: WALLS - WWF AREA 0.24 FLOOR - AREA 0.27 - #5 BAR @ 12" C/C TOP AND BOTTOM MAT.
4. WEIGHT: TOTAL - 17,113 LBS.
 FIRST POUR - 9,216 LBS
 SECOND POUR - 7,897 LBS
5. JOINT SEAL: CONCRETE SEALANTS INC. CS-102.
6. ICAST TO INSTALL INTERNALS.
7. CONTECH'S LOGO AS WELL AS THE INLETS AND OUTLETS MUST BE STENCILED ONTO THE STRUCTURE.

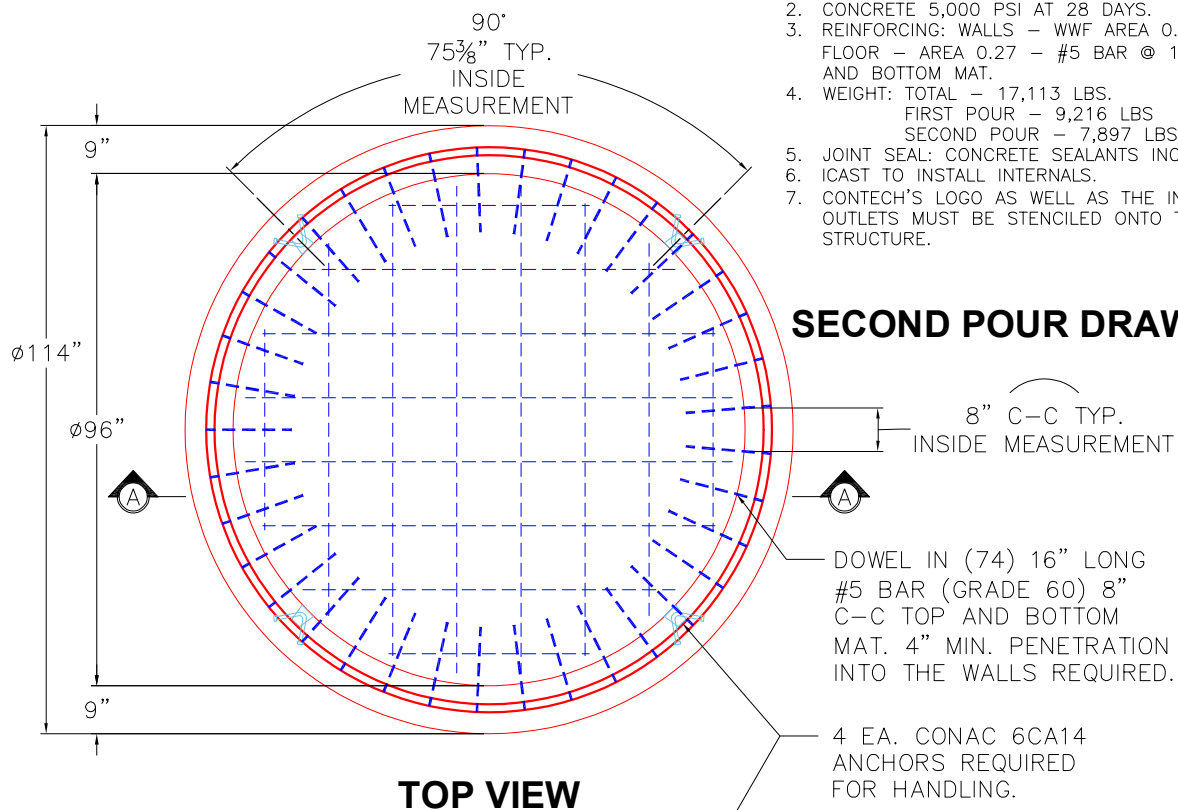

SECOND POUR DRAWING

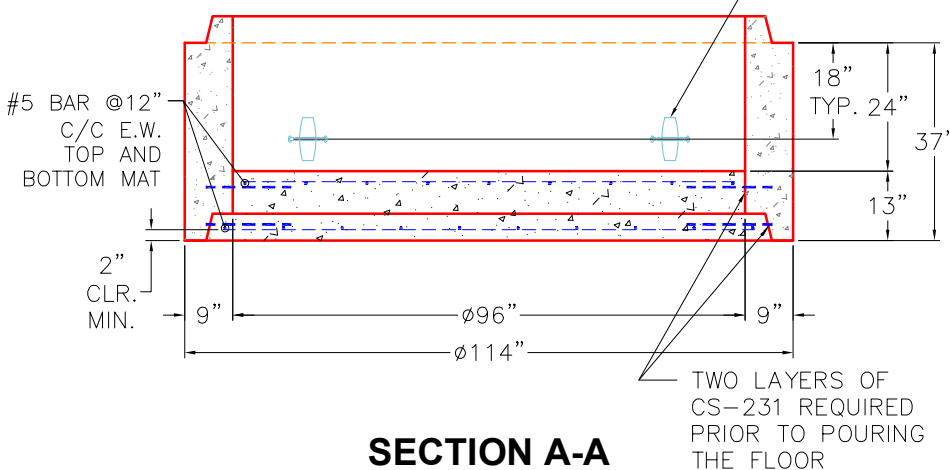

Coating (Int): Coating (Ext):	Seam Up: Tongue Seam Dn: n/a	Wall Thickness: 9" Floor Height: 13"	Height (Int): 24" Height (Ext): 37"	Weight (Net): 17113 lb Volume (Net): 4.37cu.yd
----------------------------------	---------------------------------	-----------------------------------------	----------------------------------------	---------------------------------------------------