

**Job Name: 26-1648 837557 71 Trade Center**  
**Job Location: La Grange, KY**  
**Contractor: Contech Engineering Solutions**

PC: T. Sekula  
 TECH: S. Felletter  
 Plant: Beaver Dam



Structure ID: **10-CS-8**  
 Spec: Storm-Pipe Centered  
 Type: STM.MH  
 Size: 96"

Rim: 727.65'  
 Invert: 713.85'  
 Rim to Invert: 13.8'

Sump: 82.044"  
 Floor (Top): 707.013'  
 Floor Height: 13"

Floor (Bot): 705.93'  
 Overall Height: 20.833'  
 Slack: 10.644"

Structure Notes:  
 4" CASTING BY OTHERS

LIFTING ANCHORS TO BE INSTALLED  
 ON THE OUTSIDE OF THE STRUCTURE

ICAST TO INSTALL THE INTERNALS

CONTECH'S LOGO AS WELL AS THE  
 INLET AND OUTLET MUST BE  
 STENCILED ONTO THE STRUCTURE

STRUCTURE SUMMARY:

P5) 24" - CASTING HEIGHT - 4"	0 lb
P4) 96" - MH FLAT TOP SPEC. (2 - 24"Ø HOLES) F/G - 17"	10015 lb
P3) 96" - MH RISER T/G - 96"	23915 lb
P2) 96" - MH RISER T/G - 96"	23215 lb
P1) 96" - MH MONOBASE 13F, Custom Ht T/n - 24"	17113 lb
1) CVSTENCILING	0 lb
1) ASSEMBLY REQUIRED	0 lb
3) 96" - Conseal CS-102 1.00"	0 lb
2) Hole - 24	0 lb
<b>Structure Total:</b>	<b>74259 lb</b>

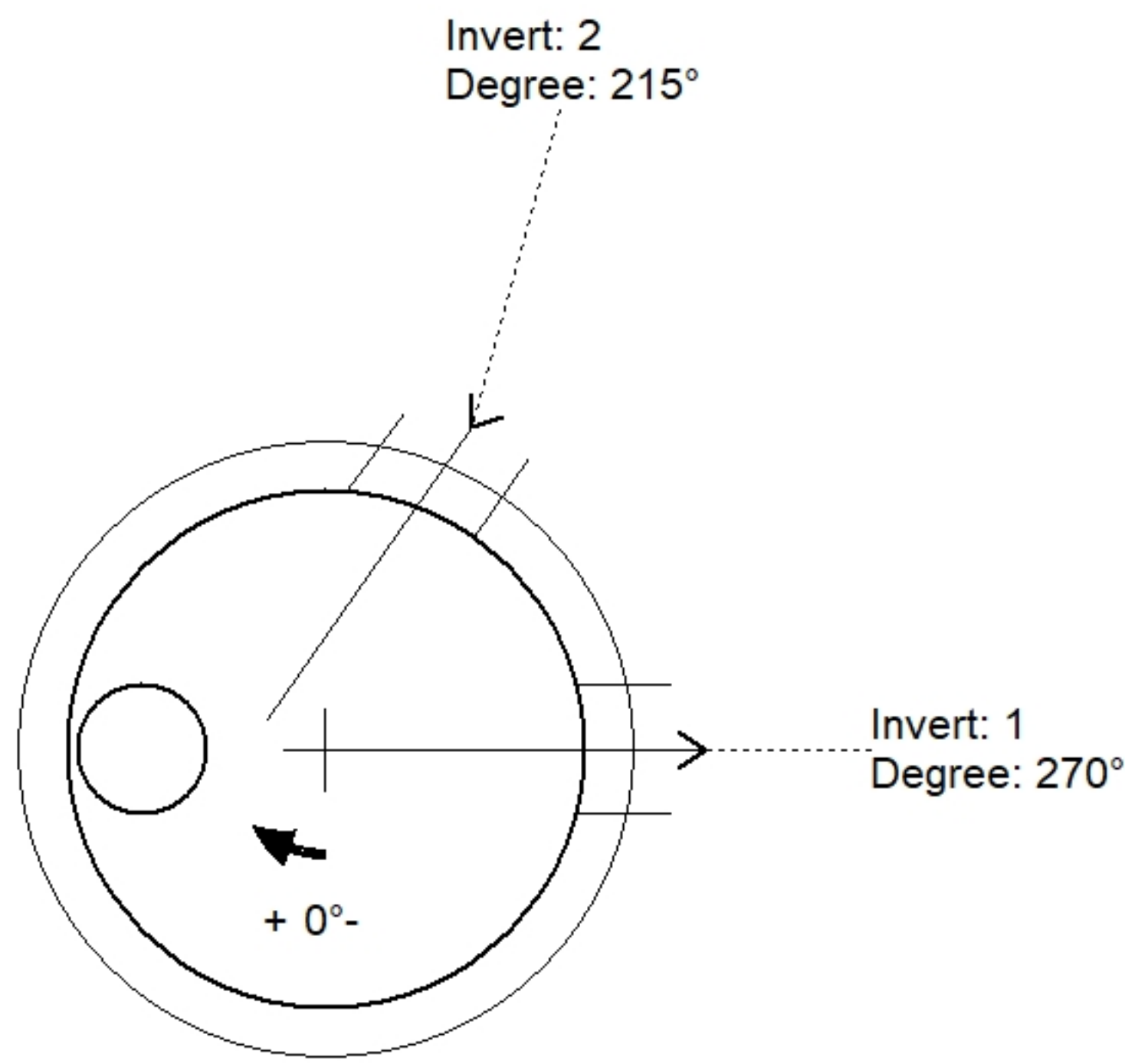

Position	Elev	Angle	Pipe	Pipe OD	Hole	Connector	Up (")	Ref
Rim	727.65'							
Reducer								
Invert 1	713.85'	270°	18" HDPE	21.2"	24"	Hole 24	50.044"	P2
Invert 2	713.85'	215°	18" HDPE	21.2"	24"	Hole 24	50.044"	P2
Invert 3								
Invert 4								
Invert 5								
Invert 6								
Invert 7								
Invert 8								

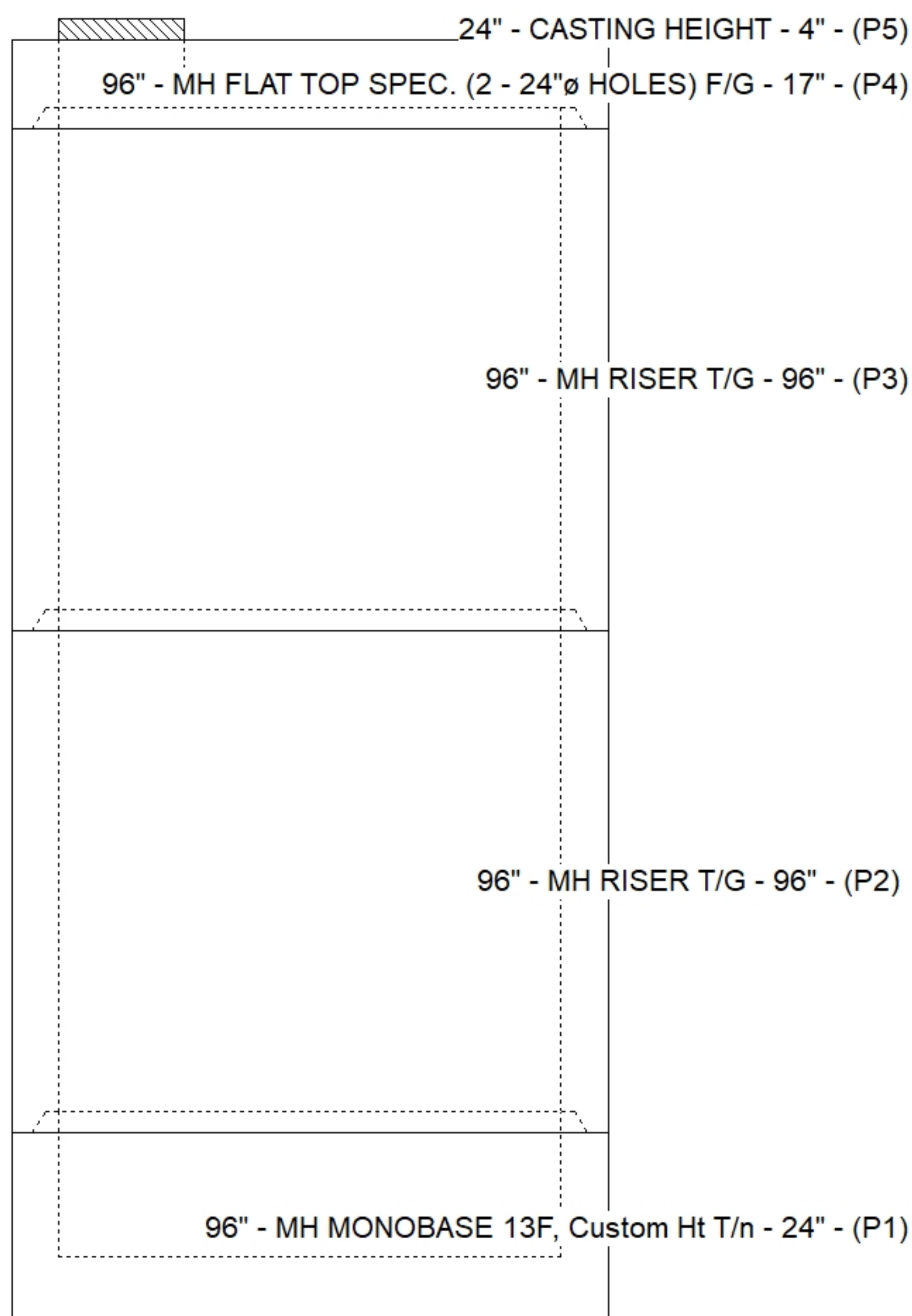

Default - Interior Dimensions

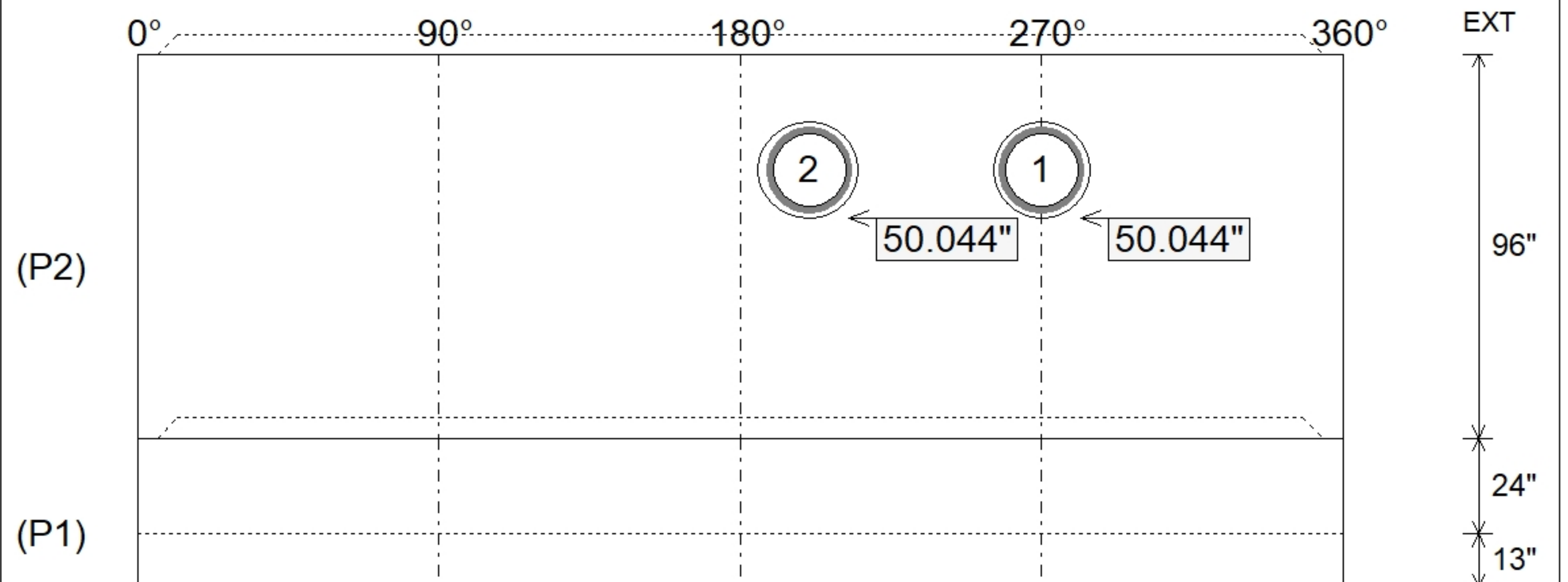

Submittal Drawing  
 3/20/2026 3:48:09 PM

SUBMITTAL  
 APPROVED BY: