

Job Name: 26-1643 - Jackson Utility Relocation
 Job Location: Jackson, KY
 Contractor: Triton Construction, Inc.

Plant: 100

3/31/2026 7:25:29 AM

Tech: J. Horsley

PC: E. Bradley



Structure ID: N44-5 SS-MH

P3 MH048CN36CDARED

ECC CONE w/ 24" HOLE, w/ConBlock-CDA Red F/G

- P4) 24" - CASTING HEIGHT - 7"
- P3) 48" - ECC CONE w/ 24" HOLE, w/ConBlock-CDA Red F/G - 36"
- P2) 48" - MH RISER w/ConBlock-CDA Red T/G - 24"
- P1) 48" - MH BASE w/FLANGE (08F/08EF) w/ConBlock-CDA Red T/n - 28"
- 1) 48" - MH INVERT CHANNEL w/ConBlock-CDA Red - FULL HEIGHT
- 1) JOINT WRAP - 0.065"x6"x50' CONSEAL CS212
- 1) JOINT WRAP PRIMER - CONSEAL CS-75 (1 gal.)
- 1) ADMIXTURE CONBLOCK CDA RED
- 1) CASTING - HOE MC-350 F/C Sanitary
- 2) 48" - Conseal CS-102 1.00" (Double)
- 2) PSX - 16L NYLO
- 7) MH Step ML-10-TDS-NCR - 10"

0 lb
 2251 lb
 1677 lb
 4672 lb
 1440 lb
 0 lb
 0 lb
 0 lb
 305 lb
 0 lb
 16 lb
 0 lb

Structure Total: 10360 lb

Structure Notes:

1. PER ASTM C-478 SPECIFICATIONS
2. CONCRETE: 4,000 PSI AT 28 DAYS
3. REINFORCEMENT: PER ASTM A615
4. CONBLOCK CDA RED ADMIXTURE REQUIRED
5. STEPS REQUIRED
6. HOE MC-350 FRAME & COVER "SANITARY" SUPPLIED BY ICAST

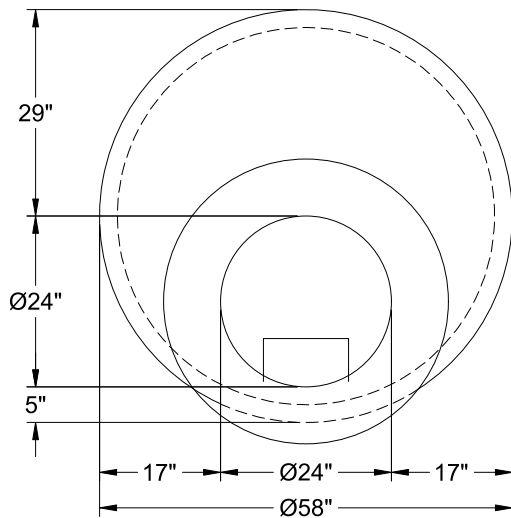

48" - ECC CONE w/ 24" HOLE, w/ConBlock-CDA Red F/G - 36" - (P3)

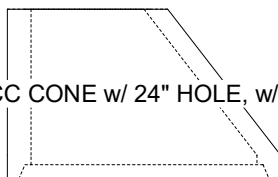

Coating (Int):
 Coating (Ext):

Seam Up: Flat
 Seam Dn: Groove

Wall Thickness: 5"

Height (Ext): 36"

Weight (Net): 2251 lb
 Volume (Net): 0.57cu.yd