

Job Name: 26-1643 - Jackson Utility Relocation
 Job Location: Jackson, KY
 Contractor: Triton Construction, Inc.

Plant: 100

3/31/2026 7:25:29 AM

Tech: J. Horsley

PC: E. Bradley



Structure ID: N423-4 SS-MH

P2 MH048LD12CDARED

MH FLAT TOP w/24" Hole ECC w/ConBlock-CDA Red F/G

- P3) 24" - CASTING HEIGHT - 7"
- P2) 48" - MH FLAT TOP w/24" Hole ECC w/ConBlock-CDA Red F/G - 12"
- P1) 48" - MH BASE w/FLANGE (08F/08EF) w/ConBlock-CDA Red T/n - 30"
- 1) 48" - MH INVERT CHANNEL w/ConBlock-CDA Red - FULL HEIGHT
- 1) JOINT WRAP - 0.065"x6"x50" CONSEAL CS212
- 1) JOINT WRAP PRIMER - CONSEAL CS-75 (1 gal.)
- 1) ADMIXTURE CONBLOCK CDA RED
- 1) CASTING - HOE MC-350 F/C Sanitary
- 1) 48" - Conseal CS-102 1.00" (Double)
- 2) PSX - 16L NYLO
- 2) MH Step ML-10-TDS-NCR - 10"

- 0 lb
- 1580 lb
- 4811 lb
- 1440 lb
- 0 lb
- 0 lb
- 0 lb
- 305 lb
- 0 lb
- 16 lb
- 0 lb

Structure Total: 8152 lb

Structure Notes:

1. PER ASTM C-478 SPECIFICATIONS
2. CONCRETE: 4,000 PSI AT 28 DAYS
3. REINFORCEMENT: #4 BAR @ 10" C.C. E.W. (GRADE 60) - 2" MIN. REBAR CLEARANCE (TYP)
4. CONBLOCK CDA RED ADMIXTURE REQUIRED
5. HOE MC-350 FRAME & COVER "SANITARY" SUPPLIED BY ICAST
6. LIFTERS: 3 EA. WRA016 CONAC WIRE ROPE ANCHORS FOR PLANT & FIELD HANDLING
7. TOP SURFACE TO RECEIVE FLOATED FINISH

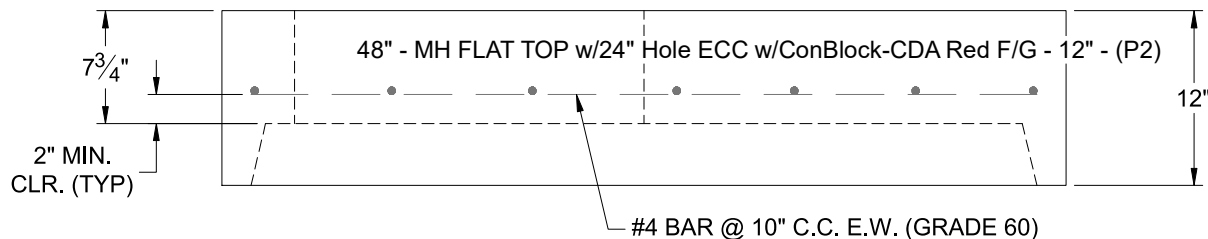
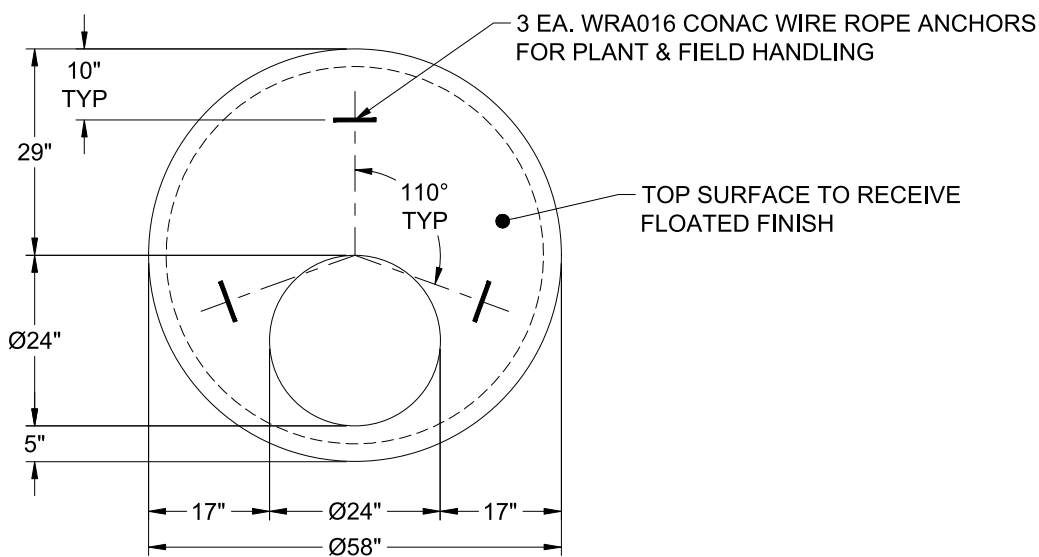

Coating (Int):
 Coating (Ext):

Seam Up: Flat
 Seam Dn: Groove

Wall Thickness: 5"

Height (Ext): 12"

Weight (Net): 1580 lb
 Volume (Net): 0.39cu.yd