

Job Name: 26-1643 - Jackson Utility Relocation
 Job Location: Jackson, KY
 Contractor: Triton Construction, Inc.

Plant: 100

3/31/2026 7:25:27 AM

Tech: J. Horsley

PC: E. Bradley



Structure ID: N421-2 SS-MH

P5 GR3CDARED

GRADE RING w/ConBlock-CDA Red F/F

- P6) 24" - CASTING HEIGHT - 7"
- P5) 24" - GRADE RING w/ConBlock-CDA Red F/F - 3"
- P4) 48" - ECC CONE w/ 24" HOLE, w/ConBlock-CDA Red F/G - 36"
- P3) 48" - MH RISER w/ConBlock-CDA Red T/G - 48"
- P2) 48" - MH RISER w/ConBlock-CDA Red T/G - 60"
- P1) 48" - MH BASE w/FLANGE (08F/08EF) w/ConBlock-CDA Red T/n - 29"
- 1) 48" - MH INVERT CHANNEL w/ConBlock-CDA Red - FULL HEIGHT
- 1) JOINT WRAP - 0.065"x6"x50' CONSEAL CS212
- 1) JOINT WRAP PRIMER - CONSEAL CS-75 (1 gal.)
- 1) ADMIXTURE CONBLOCK CDA RED
- 1) CASTING - HOE MC-350 F/C Sanitary
- 3) 48" - Conseal CS-102 1.00" (Double)
- 2) PSX - 16L NYLO
- 14) MH Step ML-10-TDS-NCR - 10"

0 lb
 202 lb
 2251 lb
 3353 lb
 4192 lb
 4742 lb
 1440 lb
 0 lb
 0 lb
 0 lb
 305 lb
 0 lb
 16 lb
 0 lb

Structure Total: 16501 lb

Structure Notes:

1. PER ASTM C-478 SPECIFICATIONS
2. CONCRETE: 4,000 PSI AT 28 DAYS
3. REINFORCEMENT: (1) #3 HOOP CENTERED (GRADE 60)

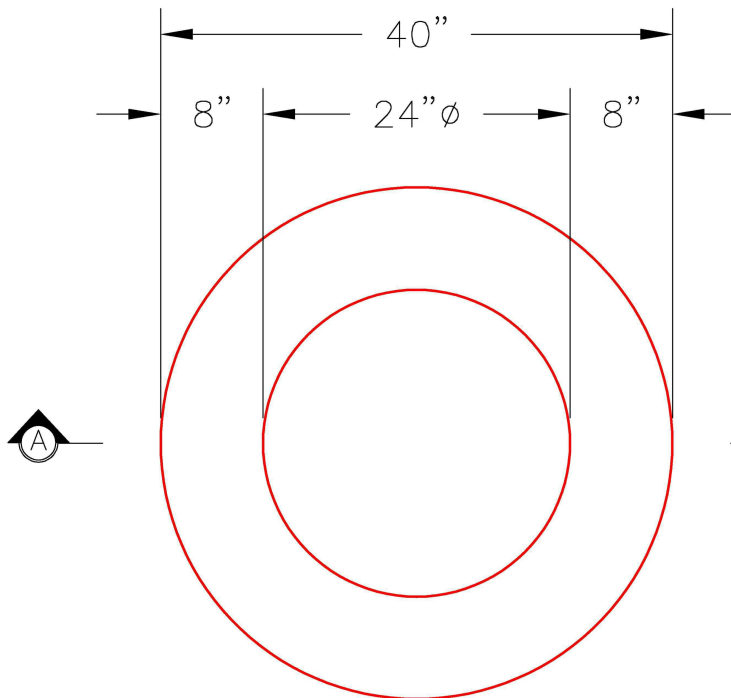

PLAN VIEW

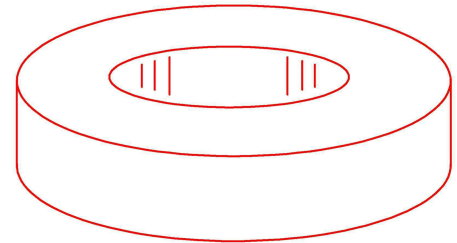

ISOMETRIC VIEW

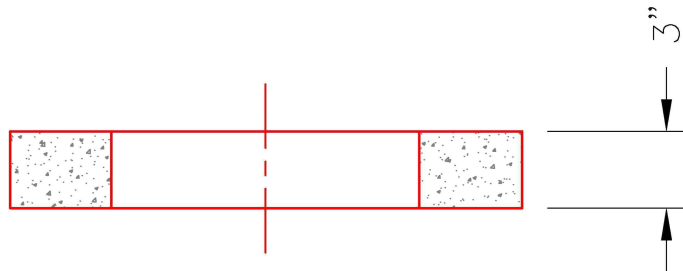

SECTION A-A

Coating (Int):
 Coating (Ext):

Seam Up: Flat
 Seam Dn: Flat

Wall Thickness: 8"

Height (Ext): 3"

Weight (Net): 202 lb
 Volume (Net): 0.05cu.yd