

Job Name: 26-1643 - Jackson Utility Relocation  
 Job Location: Jackson, KY  
 Contractor: Triton Construction, Inc.

Plant: 100  
 3/31/2026 7:25:26 AM

Tech: J. Horsley  
 PC: E. Bradley



**Structure ID: N421-2 SS-MH**

**P4 MH048CN36CDARED**

**ECC CONE w/ 24" HOLE, w/ConBlock-CDA Red F/G**

P6) 24" - CASTING HEIGHT - 7"	0 lb
P5) 24" - GRADE RING w/ConBlock-CDA Red F/F - 3"	202 lb
P4) 48" - ECC CONE w/ 24" HOLE, w/ConBlock-CDA Red F/G - 36"	2251 lb
P3) 48" - MH RISER w/ConBlock-CDA Red T/G - 48"	3353 lb
P2) 48" - MH RISER w/ConBlock-CDA Red T/G - 60"	4192 lb
P1) 48" - MH BASE w/FLANGE (08F/08EF) w/ConBlock-CDA Red T/n - 29"	4742 lb
1) 48" - MH INVERT CHANNEL w/ConBlock-CDA Red - FULL HEIGHT	1440 lb
1) JOINT WRAP - 0.065"x6"x50' CONSEAL CS212	0 lb
1) JOINT WRAP PRIMER - CONSEAL CS-75 (1 gal.)	0 lb
1) ADMIXTURE CONBLOCK CDA RED	0 lb
1) CASTING - HOE MC-350 F/C Sanitary	305 lb
3) 48" - Conseal CS-102 1.00" (Double)	0 lb
2) PSX - 16L NYLO	16 lb
14) MH Step ML-10-TDS-NCR - 10"	0 lb
<b>Structure Total:</b>	<b>16501 lb</b>

Structure Notes:  
 1. PER ASTM C-478 SPECIFICATIONS  
 2. CONCRETE: 4,000 PSI AT 28 DAYS  
 3. REINFORCEMENT: PER ASTM A615  
 4. CONBLOCK CDA RED ADMIXTURE REQUIRED  
 5. STEPS REQUIRED  
 6. HOE MC-350 FRAME & COVER "SANITARY" SUPPLIED BY ICAST

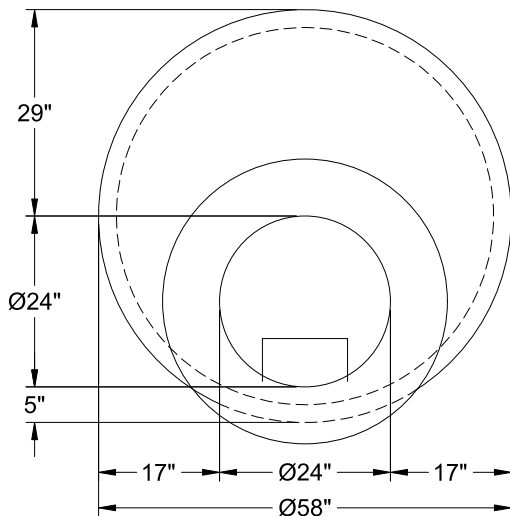

48" - ECC CONE w/ 24" HOLE, w/ConBlock-CDA Red F/G - 36" - (P4)

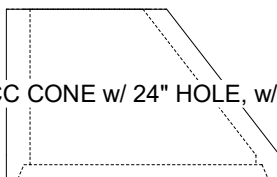

Coating (Int):  
 Coating (Ext):

Seam Up: Flat  
 Seam Dn: Groove

Wall Thickness: 5"

Height (Ext): 36"

Weight (Net): 2251 lb  
 Volume (Net): 0.57cu.yd