

Job Name: 26-1642 ADS Brightleaf & Narrows Rd.
 Job Location: Erlanger, KY
 Contractor: ADS Advanced Drainage Systems, Inc.

Plant: Beaver Dam
 4/2/2026 12:37:36 PM

Tech: S. Felletter
 PC: C. Goff



Structure ID: 2

P4 MH036LD10

MH FLAT TOP w/ 24" Ctr. Hole

- P5) 24" - CASTING HEIGHT - 7"
- P4) 36" - MH FLAT TOP w/ 24" Ctr. Hole - 10"
- P3) 36" - MH RISER - 12"
- P2) 36" - MH RISER Custom Ht - 70"
- P1) 36" - MH BASE - 18"
- 1) ASSEMBLY REQUIRED
- 1) CASTING - HOE MC-375 F/C Storm
- 3) 36" - Conseal CS-102 1.00" (Double)
- 2) Hole - 20

Structure Notes:
 1. PER ASTM C478 SPECIFICATIONS.
 2. CONCRETE = 4,000 PSI AT 28 DAYS.
 3. CASTING BY ICAST (HOE MC-375 F/C "STORM").

REINFORCING PER ASTM A615 (GRADE 60).
 - TOP SLAB (As .62) #5 BARS AT 6" C.C.E.W..
 - RISER/WALLS (As .12)
 - FLOOR (As .31) #5 BARS AT 12" C.C.E.W.

Structure Total: 5929 lb

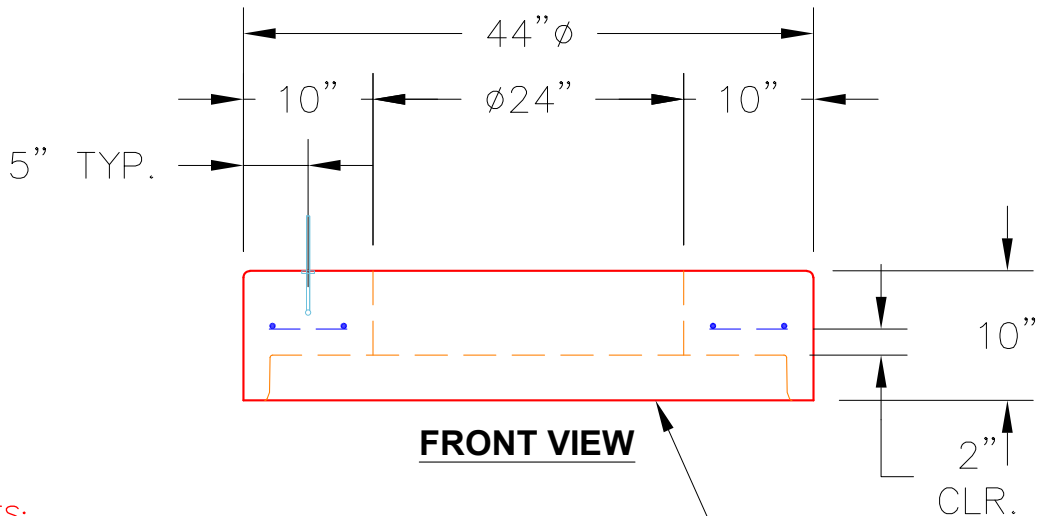
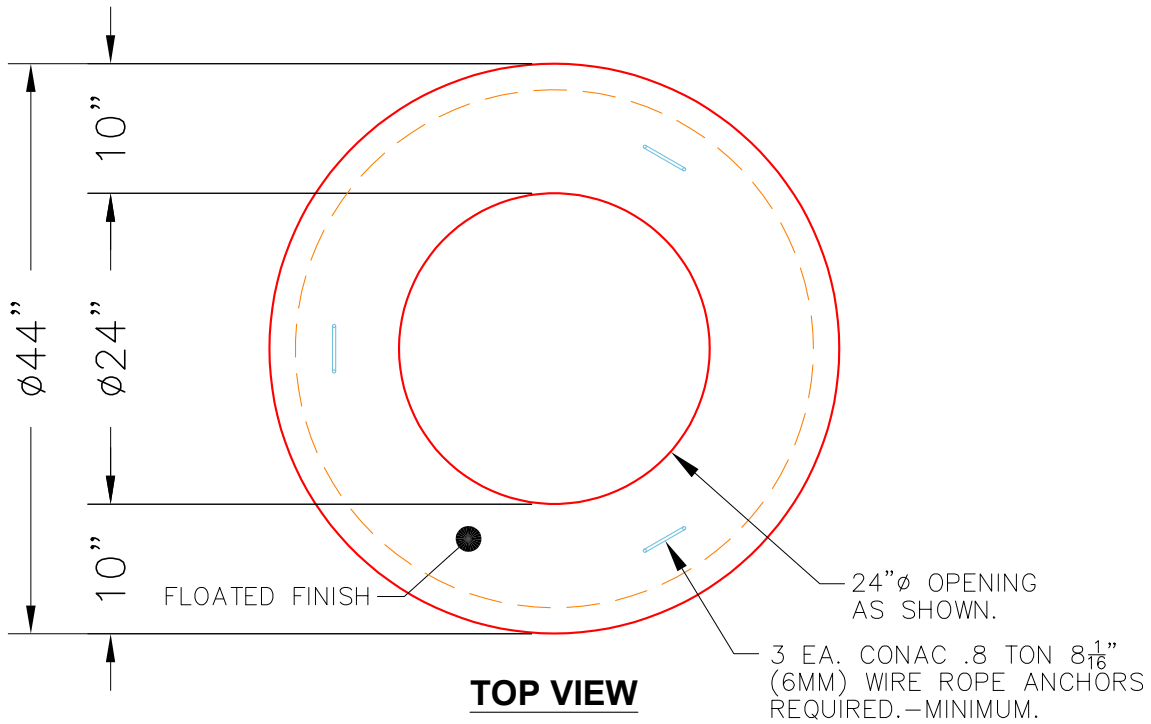

- NOTES:**
1. MANUFACTURED TO ASTM C-478 (LATEST REVISION).
 2. CONCRETE: 4,000 PSI AT 28 DAYS.
 3. REINFORCING: #5 BAR @ 6" O.C. E.W. (GRADE 60).

Coating (Int): Coating (Ext):	Seam Up: Flat Seam Dn: Groove	Wall Thickness: 4"	Height (Ext): 10"	Weight (Net): 896 lb Volume (Net): 0.23cu.yd
----------------------------------	----------------------------------	--------------------	-------------------	---