

**PLAN VIEW  
(UPSIDE DOWN)**

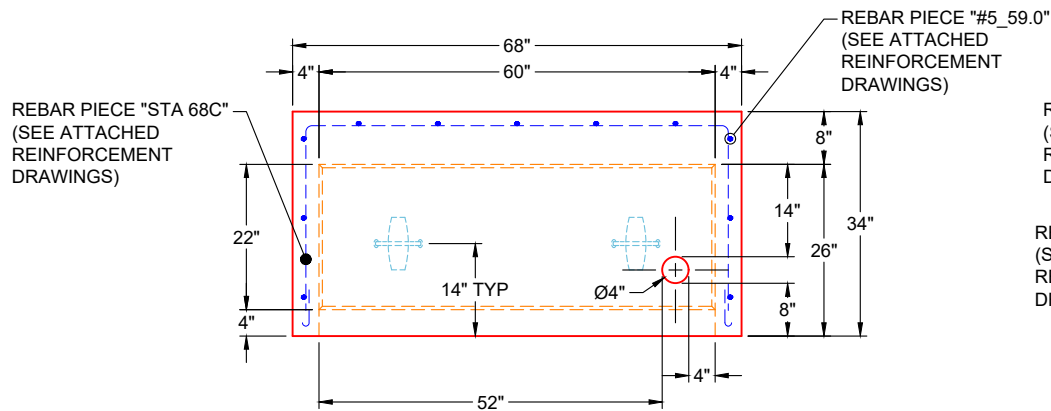

**FRONT VIEW  
(UPSIDE DOWN)**

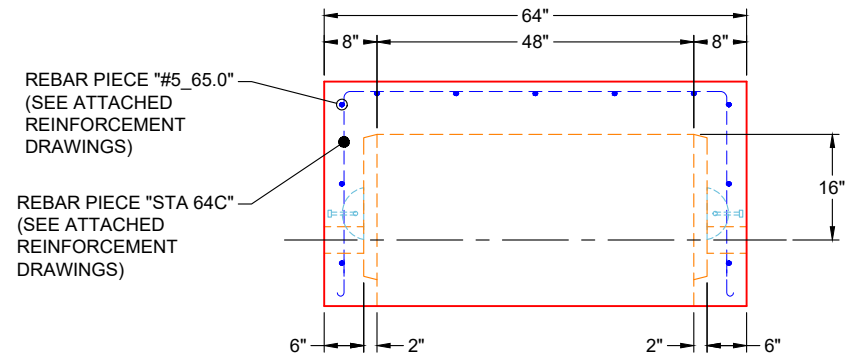

**SIDE VIEW  
(UPSIDE DOWN)**

**GENERAL NOTES:**

1. MANUFACTURED TO ASTM C-913 (LATEST REVISION)
2. CONCRETE: 5,000 PSI AT 28 DAYS
3. REINFORCEMENT: PER ATTACHED REINFORCEMENT DRAWINGS - MIN. 1½" REBAR CLEARANCE
4. WEIGHT: 5,890 LBS

**PRODUCTION NOTE**  
**PLEASE USE SPECIFIC VSG 48" X 60"**  
**MOLD FOR THIS STRUCTURE**

**PRODUCTION WORK ORDER**

PRODUCT I.D.: BX4860-04W08F-BAVF

DESCRIPTION: 48" X 60" X 26" VAULT BASE



**QUALITY CONTROL CHECKLIST**

- ALL DIMENSIONS CORRECT.
- LIFTERS INSTALLED.
- HOLE LOCATION(S) CORRECT.
- REINFORCING CORRECT.
- SURFACE QUALITY ACCEPTABLE.
- EDGES CHAMFERED.
- ALL PATCHWORK ACCEPTABLE.

PRODUCT VIEW: UPSIDE DOWN

CUSTOMER: ENDESOL, INC.

PLANT: BEAVER DAM, KY

PROJECT: 4-23 691254775

WEIGHT: 5,890 LBS

STRUCTURE: 4-61618 1 (EFX-60 STATIONARY VAULT)

TOP SECTION JOINT: N / A

ORDER NO: 26-1618

BASE SECTION JOINT: FLAT

PE: J.H. ROSS

DRAWING: J. HORSLEY

QC CHECK INITIALS:

DATE: 03/25/26

SCALE: NTS

PG. 2 OF 2

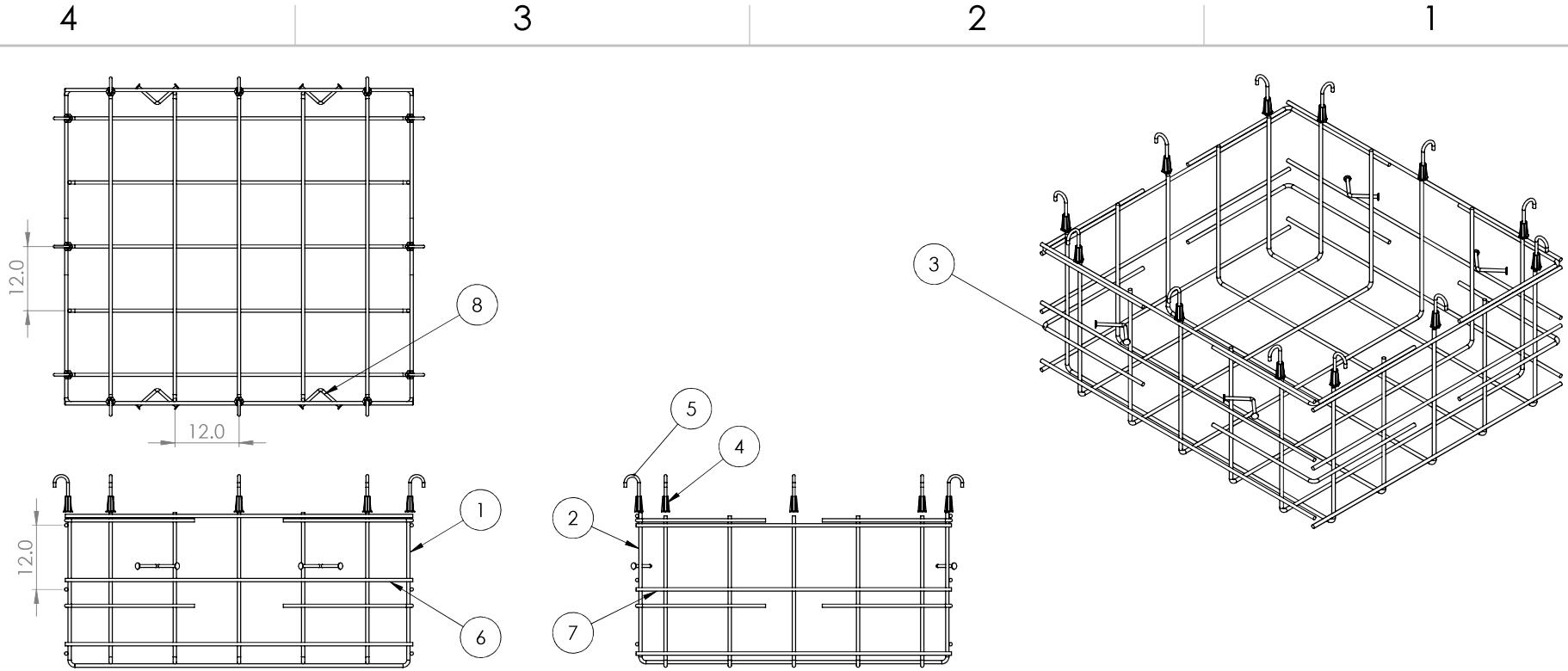

ITEM NO.	PART NUMBER	DESCRIPTION	QTY.
1	STA 68C	#5 Rebar C Shape	5
2	STA 64C	#5 Rebar C Shape	5
3	STA 2424L	#5 Rebar L 24" x 24"	8
4	TSI 50x278	Threaded Anchor	12
5	J Bolt 42117	#4 Rebar J	12
6	#5_65.0	#5 Rebar 65" Long	6
7	#5_59.0	#5 Rebar 59" Long	6
8	LUL514G	Lift Hook	4

- NOTES:
1. Rebar: #5 A614 Grade 60
  2. All Rebar to have 1.5" Cover Minimum

**PROPRIETARY AND CONFIDENTIAL**  
 THE INFORMATION CONTAINED IN THIS DRAWING IS THE SOLE PROPERTY OF ENDESOL INC. ANY REPRODUCTION IN PART OR AS A WHOLE WITHOUT THE WRITTEN PERMISSION OF ENDESOL INC. IS PROHIBITED.

		UNLESS OTHERWISE SPECIFIED:	NAME	DATE
		DIMENSIONS ARE IN INCHES	DRAWN	CMJ 3-25-16
		TOLERANCES:	CHECKED	JHR 3-25-16
		FRACTIONAL ± 1/8"	ENG APPR.	XXXX XXXX
		TWO PLACE DECIMAL ±.13	MFG APPR.	XXXX XXXX
		THREE PLACE DECIMAL ±.125	Q.A.	XXXX XXXX
		INTERPRET GEOMETRIC TOLERANCING PER:	COMMENTS:	
		MATERIAL	#5 REBAR	
		FINISH	MILL	
NEXT ASSY	USED ON	APPLICATION		
		DO NOT SCALE DRAWING		

**ENDESOL**

TITLE: EFX-60 Stationary Rebar Detail

SIZE	DWG. NO.	REV
<b>B</b>	EFX-60 STA Rebar	<b>X2</b>

SCALE: 1:20 WEIGHT: SHEET 1 OF 1

**PROJECT: 4-23 691254775**  
**STRUCTURE: 4-61618 1**  
**JOB NUMBER: 26-1618**

2

1

B

B



A

A

PROJECT: 4-23 691254775  
 STRUCTURE: 4-61618 1  
 JOB NUMBER: 26-1618



981 W. 7th Street  
 Beaver Dam, KY  
 42320  
 P 270-363-2238  
 F 270-363-2234  
 iCastinc.com

DIMENSIONS ARE IN INCHES  
 TOLERANCES:  
 FRACTIONAL  
 ANGULAR: MACH BEND  
 TWO PLACE DECIMAL  
 THREE PLACE DECIMAL

MATERIAL

FINISH

DO NOT SCALE DRAWING

	NAME	DATE
DRAWN	xxx	
CHECKED		
ENG APPR.		
MFG APPR.		
Q.A.		
COMMENTS:		

#5 Rebar C  
 Shape

SIZE <b>A</b>	DWG. NO. STA 68C	REV.
SCALE:1:50	WEIGHT:	SHEET 1 OF 1

2

1

PROPRIETARY AND CONFIDENTIAL  
 THE INFORMATION CONTAINED IN THIS DRAWING IS THE SOLE PROPERTY OF  
 INFRASTRUCTURE PRECAST INC. (iCast). ANY REPRODUCTION IN PART OR  
 AS A WHOLE WITHOUT THE WRITTEN PERMISSION OF iCast IS PROHIBITED.

2

1

B

B

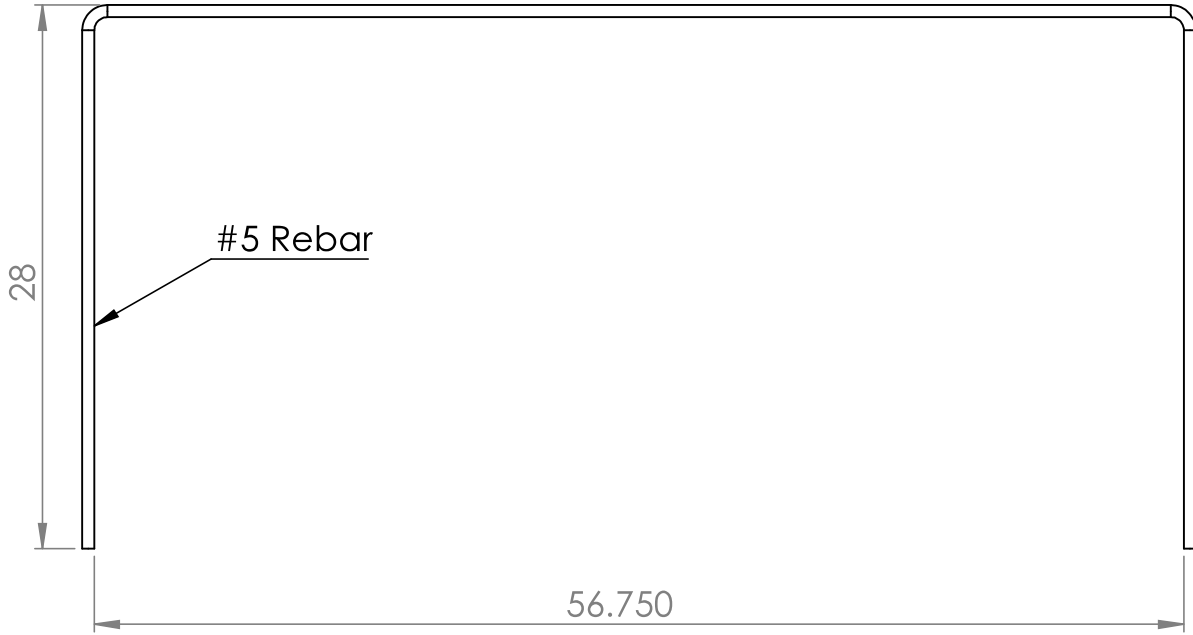

A

A

PROJECT: 4-23 691254775  
 STRUCTURE: 4-61618 1  
 JOB NUMBER: 26-1618



981 W. 7th Street  
 Beaver Dam, KY  
 42320  
 P 270-363-2238  
 F 270-363-2234  
 iCastinc.com

DIMENSIONS ARE IN INCHES  
 TOLERANCES:  
 FRACTIONAL  
 ANGULAR: MACH BEND  
 TWO PLACE DECIMAL  
 THREE PLACE DECIMAL

MATERIAL

	NAME	DATE
DRAWN	xxx	
CHECKED		
ENG APPR.		
MFG APPR.		
Q.A.		
COMMENTS:		

#5 Rebar C  
 Shape

PROPRIETARY AND CONFIDENTIAL

THE INFORMATION CONTAINED IN THIS DRAWING IS THE SOLE PROPERTY OF INFRASTRUCTURE PRECAST INC. (iCast). ANY REPRODUCTION IN PART OR AS A WHOLE WITHOUT THE WRITTEN PERMISSION OF iCast IS PROHIBITED.

FINISH

DO NOT SCALE DRAWING

SIZE <b>A</b>	DWG. NO. STA 64C	REV.
SCALE:1:50	WEIGHT:	SHEET 1 OF 1

2

1

2

1

B

B

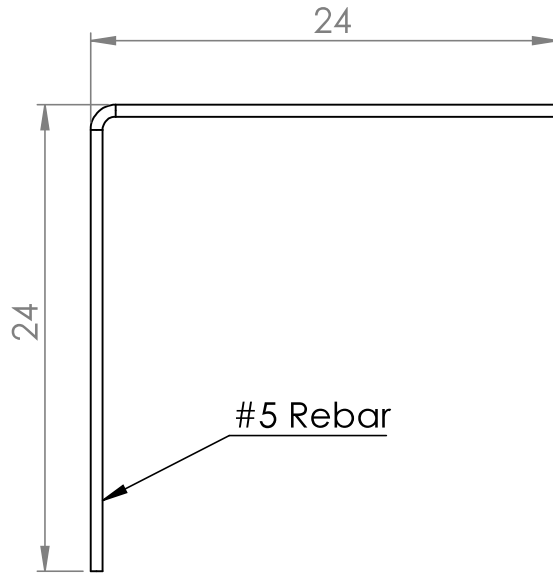

A

A

PROJECT: 4-23 691254775  
 STRUCTURE: 4-61618 1  
 JOB NUMBER: 26-1618



981 W. 7th Street  
 Beaver Dam, KY  
 42320  
 P 270-363-2238  
 F 270-363-2234  
 iCastinc.com

DIMENSIONS ARE IN INCHES  
 TOLERANCES:  
 FRACTIONAL  
 ANGULAR: MACH BEND  
 TWO PLACE DECIMAL  
 THREE PLACE DECIMAL

MATERIAL

FINISH

DO NOT SCALE DRAWING

	NAME	DATE
DRAWN	xxx	
CHECKED		
ENG APPR.		
MFG APPR.		
Q.A.		
COMMENTS:		

#5 Rebar L 24" x  
 24"

**PROPRIETARY AND CONFIDENTIAL**  
 THE INFORMATION CONTAINED IN THIS DRAWING IS THE SOLE PROPERTY OF  
 INFRASTRUCTURE PRECAST INC. (iCast). ANY REPRODUCTION IN PART OR  
 AS A WHOLE WITHOUT THE WRITTEN PERMISSION OF iCast IS PROHIBITED.

SIZE <b>A</b>	DWG. NO. STA 2424L	REV.
SCALE:1:50	WEIGHT:	SHEET 1 OF 1

2

1

**Job Number:**

26-1618

**Job Name:**

4-23 691254775

**Structure:**

EFX-60 Stationary Vault 1

**Note:**

Nosing Kit To Be Shipped. See Chad Jarvis.