

**PLAN VIEW
(UPSIDE DOWN)**

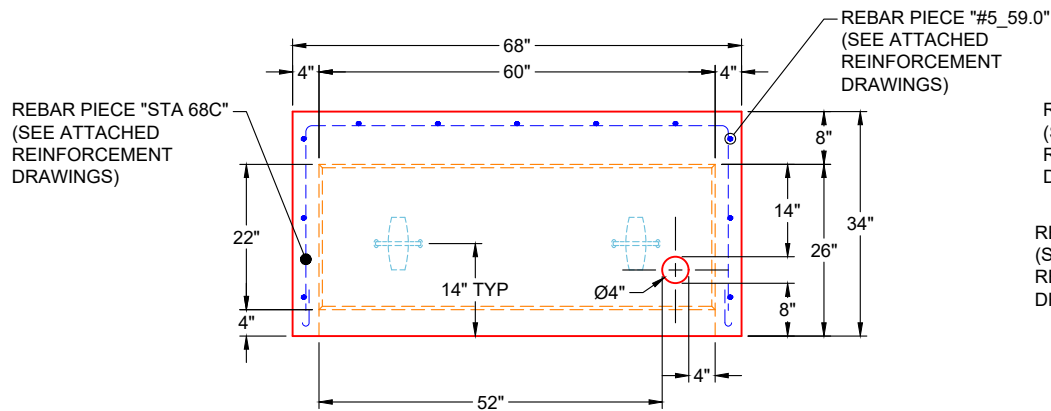

**FRONT VIEW
(UPSIDE DOWN)**

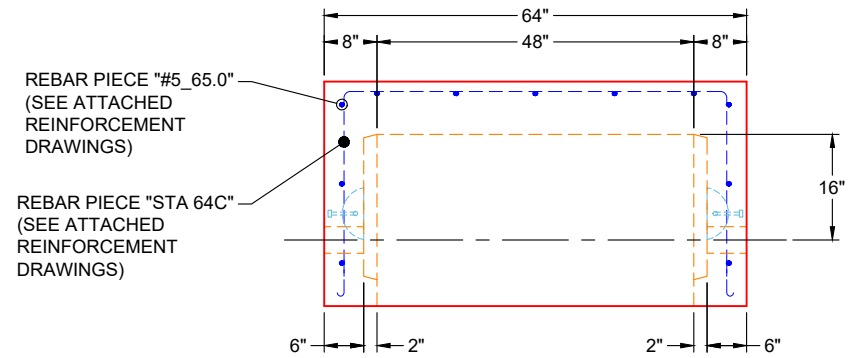

**SIDE VIEW
(UPSIDE DOWN)**

GENERAL NOTES:

1. MANUFACTURED TO ASTM C-913 (LATEST REVISION)
2. CONCRETE: 5,000 PSI AT 28 DAYS
3. REINFORCEMENT: PER ATTACHED REINFORCEMENT DRAWINGS - MIN. 1½" REBAR CLEARANCE
4. WEIGHT: 5,890 LBS

PRODUCTION NOTE
PLEASE USE SPECIFIC VSG 48" X 60"
MOLD FOR THIS STRUCTURE

PRODUCTION WORK ORDER

PRODUCT I.D.: BX4860-04W08F-BAVF

DESCRIPTION: 48" X 60" X 26" VAULT BASE



QUALITY CONTROL CHECKLIST

- ALL DIMENSIONS CORRECT.
- LIFTERS INSTALLED.
- HOLE LOCATION(S) CORRECT.
- REINFORCING CORRECT.
- SURFACE QUALITY ACCEPTABLE.
- EDGES CHAMFERED.
- ALL PATCHWORK ACCEPTABLE.

PRODUCT VIEW: UPSIDE DOWN

CUSTOMER: ENDESOL, INC.

PLANT: BEAVER DAM, KY

PROJECT: 1-26 691249488

WEIGHT: 5,890 LBS

STRUCTURE: 4-61615 (EFX-60 STATIONARY VAULT)

TOP SECTION JOINT: N / A

ORDER NO: 26-1615

BASE SECTION JOINT: FLAT

PE: J.H. ROSS

DRAWING: J. HORSLEY

QC CHECK INITIALS:

DATE: 03/25/26

SCALE: NTS

PG. 2 OF 2

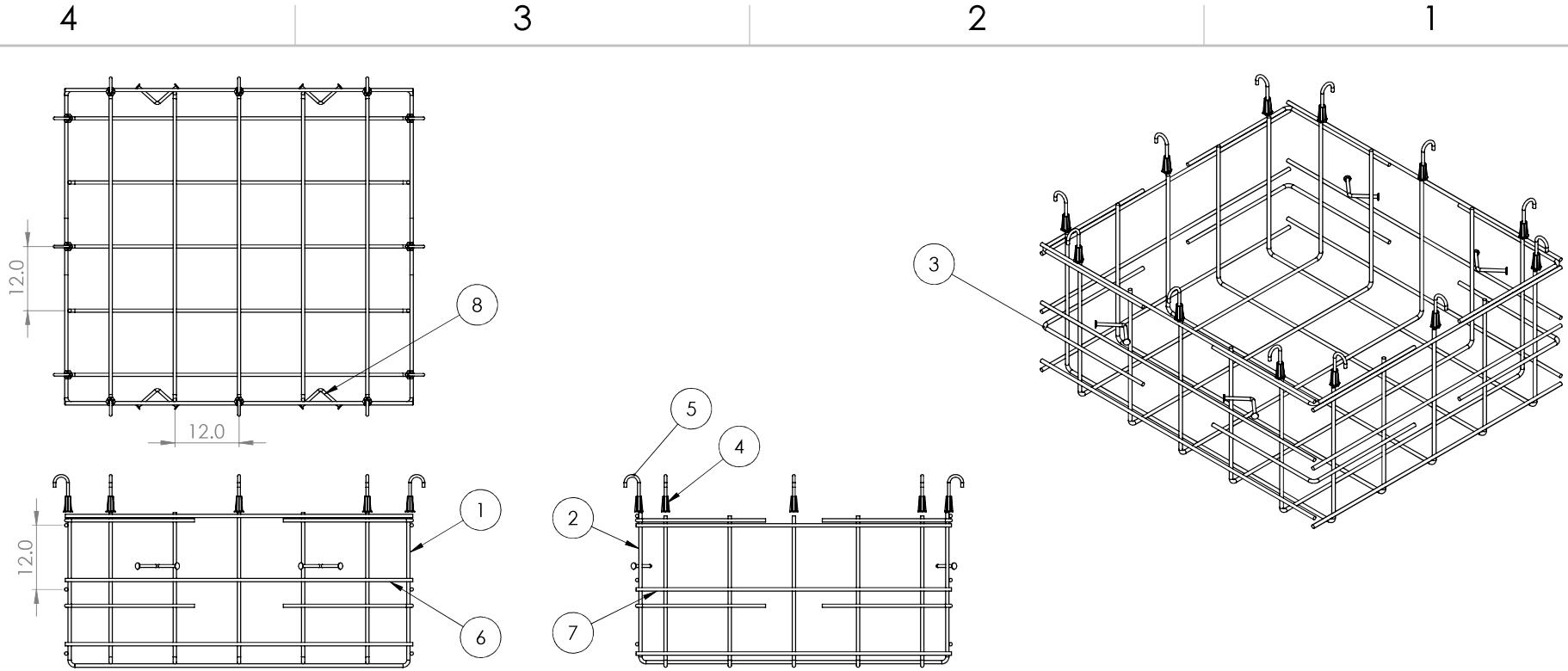

ITEM NO.	PART NUMBER	DESCRIPTION	QTY.
1	STA 68C	#5 Rebar C Shape	5
2	STA 64C	#5 Rebar C Shape	5
3	STA 2424L	#5 Rebar L 24" x 24"	8
4	TSI 50x278	Threaded Anchor	12
5	J Bolt 42117	#4 Rebar J	12
6	#5_65.0	#5 Rebar 65" Long	6
7	#5_59.0	#5 Rebar 59" Long	6
8	LUL514G	Lift Hook	4

- NOTES:
1. Rebar: #5 A614 Grade 60
 2. All Rebar to have 1.5" Cover Minimum

PROPRIETARY AND CONFIDENTIAL
 THE INFORMATION CONTAINED IN THIS DRAWING IS THE SOLE PROPERTY OF ENDESOL INC. ANY REPRODUCTION IN PART OR AS A WHOLE WITHOUT THE WRITTEN PERMISSION OF ENDESOL INC. IS PROHIBITED.

		UNLESS OTHERWISE SPECIFIED:	NAME	DATE
		DIMENSIONS ARE IN INCHES	DRAWN	CMJ 3-25-16
		TOLERANCES:	CHECKED	JHR 3-25-16
		FRACTIONAL ± 1/8"	ENG APPR.	XXXX XXXX
		TWO PLACE DECIMAL ±.13	MFG APPR.	XXXX XXXX
		THREE PLACE DECIMAL ±.125	Q.A.	XXXX XXXX
		INTERPRET GEOMETRIC TOLERANCING PER:	COMMENTS:	
		MATERIAL	#5 REBAR	
		FINISH	MILL	
NEXT ASSY	USED ON	APPLICATION	DO NOT SCALE DRAWING	

ENDESOL

TITLE: EFX-60 Stationary Rebar Detail

SIZE	DWG. NO.	REV
B	EFX-60 STA Rebar	X2

SCALE: 1:20 WEIGHT: SHEET 1 OF 1

PROJECT: 1-26 69124988
STRUCTURE: 4-61615
JOB NUMBER: 26-1615

2

1

B

B



A

A

PROJECT: 1-26 69124988
 STRUCTURE: 4-61615
 JOB NUMBER: 26-1615



981 W. 7th Street
 Beaver Dam, KY
 42320
 P 270-363-2238
 F 270-363-2234
 iCastinc.com

DIMENSIONS ARE IN INCHES
 TOLERANCES:
 FRACTIONAL
 ANGULAR: MACH BEND
 TWO PLACE DECIMAL
 THREE PLACE DECIMAL

MATERIAL

FINISH

DO NOT SCALE DRAWING

	NAME	DATE
DRAWN	xxx	
CHECKED		
ENG APPR.		
MFG APPR.		
Q.A.		
COMMENTS:		

#5 Rebar C
 Shape

PROPRIETARY AND CONFIDENTIAL
 THE INFORMATION CONTAINED IN THIS DRAWING IS THE SOLE PROPERTY OF
 INFRASTRUCTURE PRECAST INC. (iCast). ANY REPRODUCTION IN PART OR
 AS A WHOLE WITHOUT THE WRITTEN PERMISSION OF iCast IS PROHIBITED.

SIZE A	DWG. NO. STA 68C	REV.
SCALE:1:50	WEIGHT:	SHEET 1 OF 1

2

1

2

1

B

B

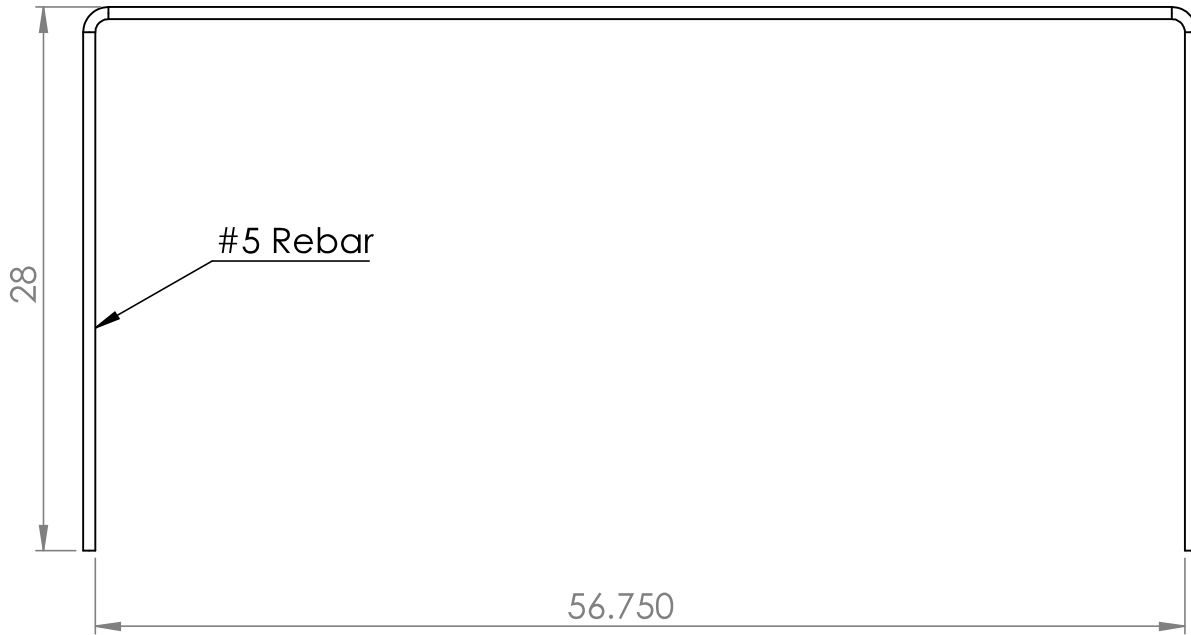

A

A

PROJECT: 1-26 69124988
 STRUCTURE: 4-61615
 JOB NUMBER: 26-1615



981 W. 7th Street
 Beaver Dam, KY
 42320
 P 270-363-2238
 F 270-363-2234
 iCastinc.com

DIMENSIONS ARE IN INCHES
 TOLERANCES:
 FRACTIONAL
 ANGULAR: MACH BEND
 TWO PLACE DECIMAL
 THREE PLACE DECIMAL

MATERIAL

FINISH

DO NOT SCALE DRAWING

	NAME	DATE
DRAWN	xxx	
CHECKED		
ENG APPR.		
MFG APPR.		
Q.A.		
COMMENTS:		

#5 Rebar C
 Shape

PROPRIETARY AND CONFIDENTIAL
 THE INFORMATION CONTAINED IN THIS DRAWING IS THE SOLE PROPERTY OF
 INFRASTRUCTURE PRECAST INC. (iCast). ANY REPRODUCTION IN PART OR
 AS A WHOLE WITHOUT THE WRITTEN PERMISSION OF iCast IS PROHIBITED.

SIZE A	DWG. NO. STA 64C	REV.
SCALE:1:50	WEIGHT:	SHEET 1 OF 1

2

1

2

1

B

B

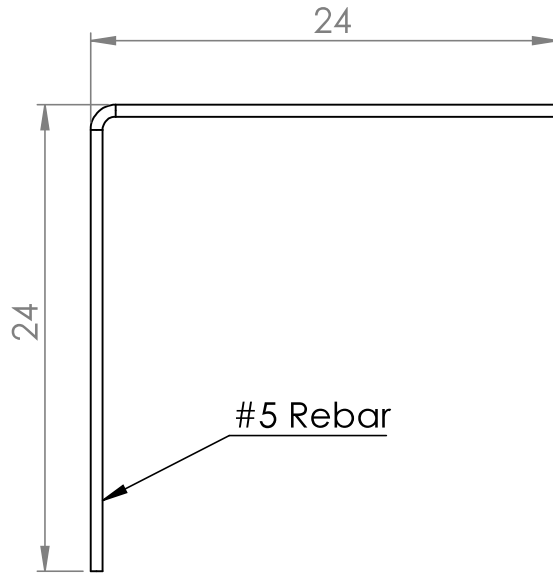

A

A

PROJECT: 1-26 69124988
 STRUCTURE: 4-61615
 JOB NUMBER: 26-1615



981 W. 7th Street
 Beaver Dam, KY
 42320
 P 270-363-2238
 F 270-363-2234
 iCastinc.com

DIMENSIONS ARE IN INCHES
 TOLERANCES:
 FRACTIONAL
 ANGULAR: MACH BEND
 TWO PLACE DECIMAL
 THREE PLACE DECIMAL

MATERIAL

FINISH

DO NOT SCALE DRAWING

	NAME	DATE
DRAWN	xxx	
CHECKED		
ENG APPR.		
MFG APPR.		
Q.A.		
COMMENTS:		

#5 Rebar L 24" x
 24"

PROPRIETARY AND CONFIDENTIAL
 THE INFORMATION CONTAINED IN THIS DRAWING IS THE SOLE PROPERTY OF
 INFRASTRUCTURE PRECAST INC. (iCast). ANY REPRODUCTION IN PART OR
 AS A WHOLE WITHOUT THE WRITTEN PERMISSION OF iCast IS PROHIBITED.

SIZE A	DWG. NO. STA 2424L	REV.
SCALE: 1:50	WEIGHT:	SHEET 1 OF 1

2

1

Job Number:

26-1615

Job Name:

1-26 691249488

Structure:

EFX-60 Stationary Vault

Note:

Nosing Kit To Be Shipped. See Chad Jarvis.