

Job Name: 26-1502 ADS Bluegrass Meadows Sec. 7A
 Job Location: Mount Washington, KY
 Contractor: ADS Advanced Drainage Systems, Inc.

Plant: Beaver Dam
 3/6/2026 1:36:45 PM

Tech: S. Felletter
 PC: C. Goff



Structure ID: 2

P4 MH096LD17-CON

MH FLAT TOP w/ 24" Conc. Hole F/G

- P5) 24" - CASTING HEIGHT - 7"
- P4) 96" - MH FLAT TOP w/ 24" Conc. Hole F/G - 17"
- P3) 96" - MH RISER Custom Ht T/G - 69"
- P2) 96" - MH RISER Custom Ht T/G - 69"
- P1) 96" - MH BASE Custom Ht T/n - 25"
- 1) ASSEMBLY REQUIRED - BRACKETS ONLY
- 1) CASTING - HOE MC-375 F/C Storm
- 3) 96" - Conseal CS-102 1.00" (Double)
- 2) Hole - 16

0 lb
 10473 lb
 16863 lb
 17189 lb
 13080 lb
 0 lb
 271 lb
 0 lb
 0 lb

Structure Total: 57876 lb

Structure Notes:

1. PER ASTM C478 SPECIFICATIONS.
 2. CONCRETE = 4,000 PSI AT 28 DAYS.
 3. CASTING BY ICAST (HOE MC-375 F/C "STORM").
 4. LIFTING ANCHORS TO BE INSTALLED ON THE OUTSIDE OF THE STRUCTURE.
 5. ASSEMBLY REQUIRED - BRACKETS ONLY.
- REINFORCING PER ASTM A615 (GRADE 60).
 - TOP SLAB (As .62) #5 BARS AT 6" C.C.E.W.
 - RISER/WALLS (As .24)
 - FLOOR (As .47) #5 BARS AT 8" C.C.E.W.

GENERAL NOTES:

1. MANUFACTURED TO ASTM C-478 (LATEST REVISION).
2. CONCRETE 5,000 PSI AT 28 DAYS.
3. WEIGHT: 10,473 LBS.
4. REINFORCING: TOP MAT: #4 BAR @ 18" C/C E.W.
 BOTTOM MAT: #5 BAR @ 12" C/C E.W.
 PER ASTM A615 (GRADE 60)

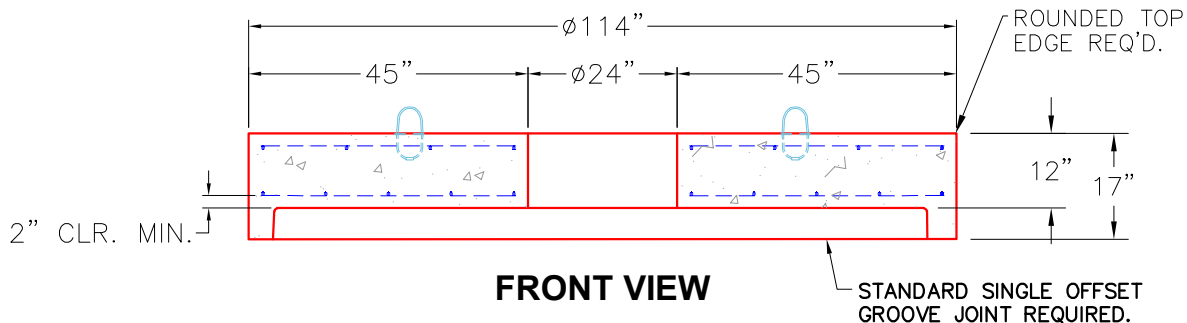
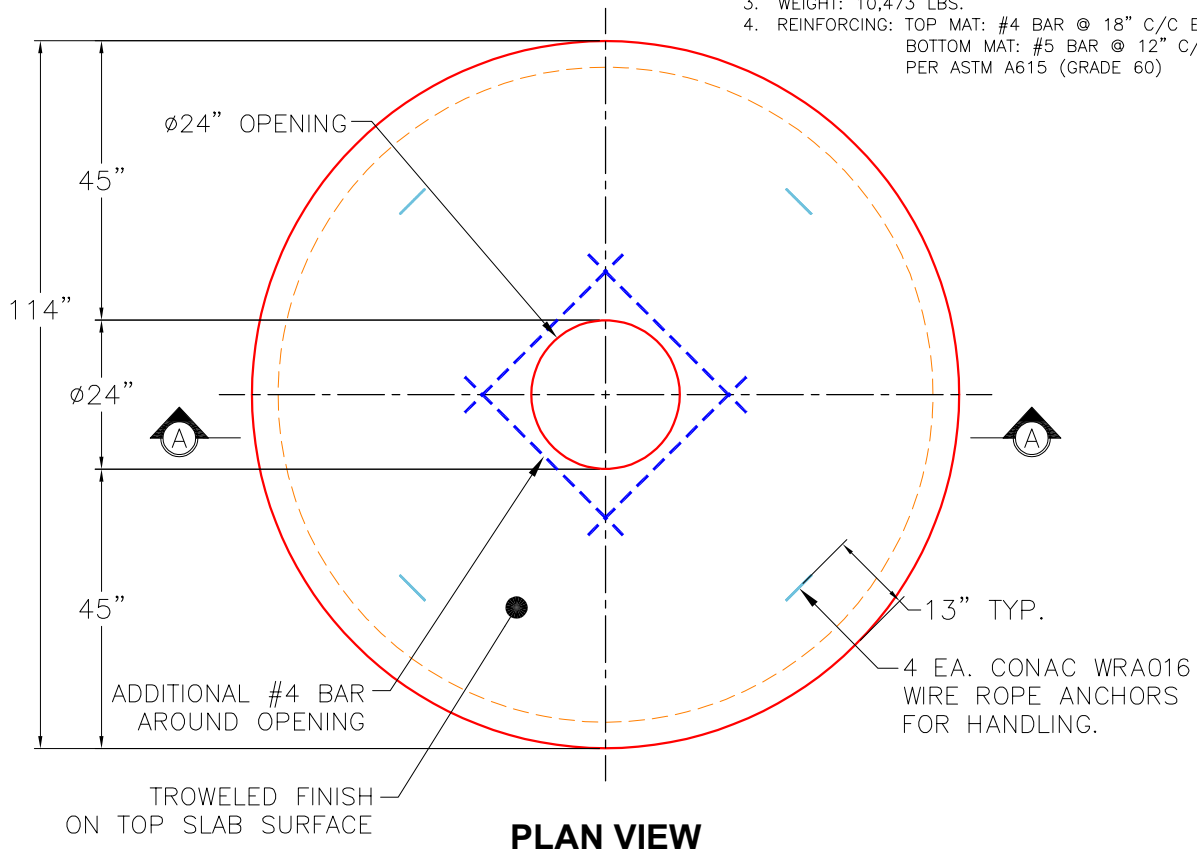

Coating (Int):
 Coating (Ext):

Seam Up: Flat
 Seam Dn: Groove

Wall Thickness: 9"

Height (Ext): 17"

Weight (Net): 10473 lb
 Volume (Net): 2.68cu.yd