

# Arcadia™ Hydrodynamic Separator Installation Guide

## Concrete Manhole Installation

This installation guide is a reference for installing the Arcadia Water Quality unit into a precast concrete structure. These directions assume the manhole base and riser have been assembled, and that the top slab has not been set.

*Note: Do not insert the inlet or outlet pipes until after the Arcadia internals have been installed. All pipes should sit flush inside the manhole. If pipes must be inserted in advance, the pipes should not protrude into the structure as they can interfere with installation of the Arcadia Internals.*

## Content

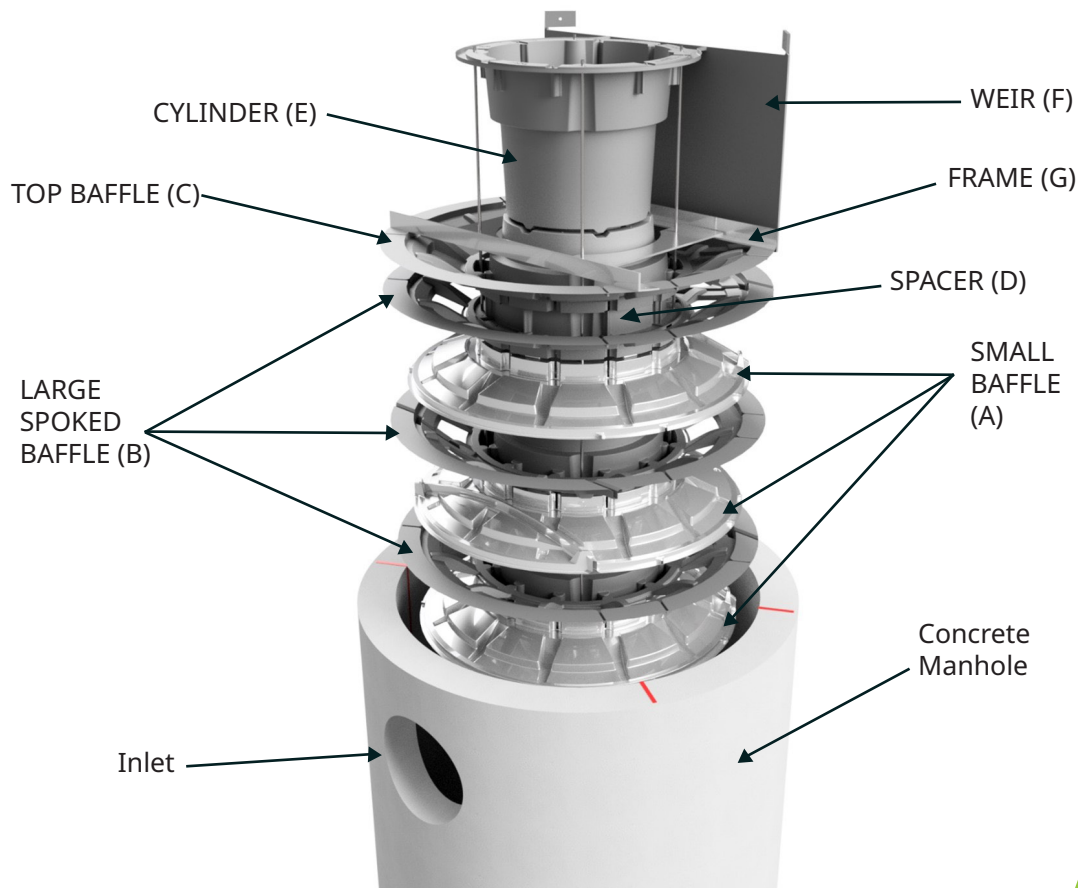
**Section 1:** Internal Components, Hardware & Tools

**Section 2:** Assembling Internal Components

**Section 3:** Mounting Brackets within Concrete Manhole Riser

**Section 4:** Transporting Assembled Arcadia Internals

**Section 5:** Installing Arcadia Internals into the Manhole – For Contactor/Jobsite



## Section 1: Internal Components, Hardware and Tools



SMALL BAFFLE (A) Qty: 3



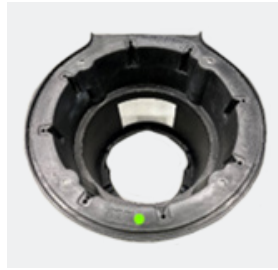
LARGE SPOKED BAFFLE (B)  
Qty: 3



TOP BAFFLE (C) Qty: 1



SPACER (D) Qty: 1



CYLINDER (E) Qty: 1



WEIR (F) Qty: 1



FRAME (G) Qty: 1

*Note: To separate baffles in shipping stack, pull from center of each baffle.*

### Hardware Provided by ADS



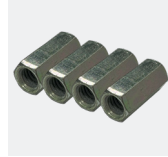
Threaded Rod  
(4 long and 4  
short) Qty: 8



Washers  
Qty: 12



Nuts  
Qty: 12



Threaded  
Coupling  
Qty: 4



Screws



Bolts for frame  
Assembly



Rod Caps  
Qty: 4



Threadlocker  
Capsules  
Qty: 2

**Please set aside the following items that will later be delivered to the jobsite along with the assembled Arcadia Unit.**

- Small Hardware package marked "Arcadia Installation, For Jobsite Contractor (Not for Precaster)".
- Conseal Roll(s).
- Copy of the Installation Guide

### Other Tools Needed

- $\frac{9}{16}$ " (14.28 mm) or  $\frac{3}{4}$ " (19.05 mm) Hand Wrench, depending on model size
- Phillips screwdriver or screw gun with Phillips bit
- 4 small hand clamps
- Pair of sawhorses

## Section 2: Assembling Internal Components

1. Suggested procedure to facilitate assembly:
  - Utilize a set of sawhorses to support the initial assembly.
  - Set the spacing between the sawhorses (outside distance, see **figure 1**) according to the table below.

Arcadia Model	Spacing in (mm)
AR3	10 (250)
AR4	15 (375)
AR5	17 (425)
AR6	19 (475)
AR8	25 (625)

2. Place one SMALL BAFFLE (A) on the saw horses with the molded word "UP" readable and facing upward."

*Note: Throughout this procedure, as you stack up the baffles, make sure to align the molded word UP for each layer. For each baffle, UP should be readable and aligned with previous layers shown in **figure 2**.*

3. Rotate the baffle as needed to ensure the word UP is aligned with that of the previous baffle, then slide one LARGE SPOKED BAFFLE (B) down the threaded rods until it rests on the previous part, as shown in **figure 3**. Each part mates with the previous part in only one orientation.
4. Place another SMALL BAFFLE (A) on top of the previous part, as shown in **figure 4**. There should now be a total of three (3) baffles in place (two SMALL BAFFLES (A) and one LARGE SPOKED BAFFLE (B)).

*Note: The long threaded rods will not reach up to the third baffle yet.*

5. One at a time, grasp each of the long threaded rods and feed / pull up through the three baffles until the washer end is tight against the underside of the bottom baffle. Place a hand clamp on each long threaded rod against the top-most baffle to hold it in position, as shown in **figures 5 and 6**.
6. Carefully lower the entire assembly to floor level. If picking up by hand, this is most easily done by grasping two of the long threaded rods in between baffles.
7. Once on the floor, remove all 4 clamps and allow long threaded rods to rest on the floor.

Scan the QR Code to watch the Arcadia installation video



Figure 1

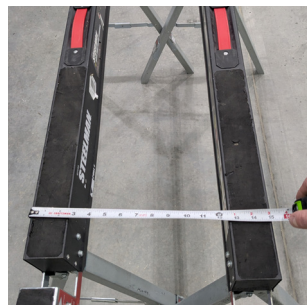


Figure 2



Figure 3



Figure 4



Figure 5

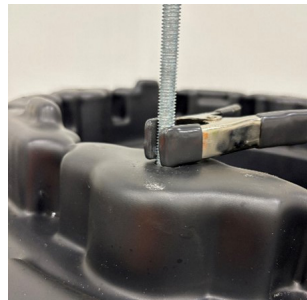


Figure 6



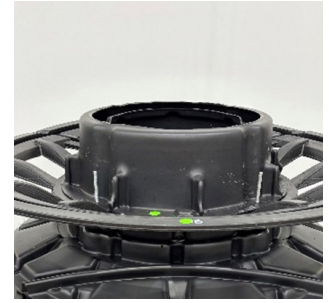
8. Repeat steps 2 & 3 once, then step 2 once more, such that two more LARGE SPOKED BAFFLE (B) and one more SMALL BAFFLE (A) have been added, for a total of six baffles, as shown in **figure 7**.
9. If SPACER (D) is supplied, slide it down the long threaded rods until it rests on the previous part. The SPACER (D) flange should be oriented down, as shown in **figure 8**.

*Note: there is no SPACER (D) provided for the 3' (0.9 m) diameter unit (AR3) and the 6' (1.8 m) diameter unit (AR6). For these two sizes, skip this step.*

**Figure 7**



**Figure 8**



10. Slide TOP BAFFLE (C) down the long threaded rods until it rests on the previous part, as shown in **figure 9**. Each part mates with the previous part in only one orientation. Check that the molded word UP, on the outer edge is readable, facing upward, and aligned with the word UP on the previous part before sliding down the rods into position.
11. Grasping each long threaded rod between baffles, push each rod up until the washer is once again snug at the bottom of the stack, as shown in **figure 10**. Hand snug a washer and nut to each long threaded rod with a wrench.

*Note: Recommended to hold the nut with the wrench and turn the threaded rod to snug.*

**Figure 9**



**Figure 10**



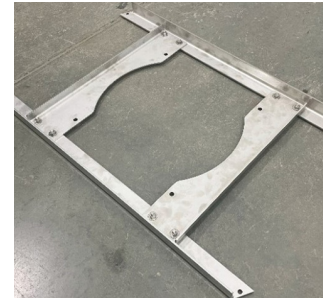
12. **Two people are needed for this step.** Assemble FRAME (G) by bolting the 4 metal pieces with provided short bolts, nuts & washers. As shown in **figure 11 and 12**.
13. Slide FRAME (G) onto the threaded rods until it rests flat on TOP BAFFLE (C). Orient FRAME (G) so that it aligns parallel to the flat portion of TOP BAFFLE (C), as shown in **figure 13**.

*Note: Make sure the frame is installed upright, with the angled bends pointing upward, as shown in figure 13.*

**Figure 11**

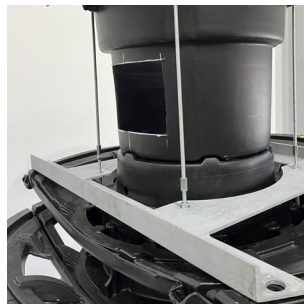


**Figure 12**



14. Add another washer and nut to each of the long threaded rods above FRAME (G). Do not screw the nut all the way down. Then, attach a threaded coupling at the top end of each long threaded rod. Screw it down until the top of the coupling is flush with the top of the threaded rod. Leave the nut just below the coupling, as shown in **figure 14**. (This is to facilitate step 17.)

**Figure 13**



**Figure 14**



15. Place a washer and nut onto the end of the four short threaded rods, screwing about 3" (75 mm) down. Orient CYLINDER (E) with the flange facing up, feed the rods from the top through the holes in the CYLINDER (E) until the nuts rest on top of the CYLINDER, as shown in **figure 15**.
16. Place CYLINDER (E) assembly on top of TOP BAFFLE (C). Each part mates with the previous part in only one orientation. Check that flat side of the flange of CYLINDER (E) is aligned with the flat side of the TOP BAFFLE (C) as shown in **figure 16**. Attach the bottom end of the 4 short threaded rods to each threaded coupling at the top of the 4 long threaded rods. Hand tighten snug by twisting the long and short threaded rods in opposite directions.
17. Secure CYLINDER (E) onto each of the 4 short threaded rods with a washer and nut at the top. Hand snug with wrench.
18. Slide WEIR (F) into top slot with the curved edge down. Ensure WEIR (F) is centered in the slot. To easily insert WEIR (F), push one end home and secure lower corner of WEIR (F) to TOP BAFFLE (C) with a screw, as shown in **figures 17 and 18**; then push the other end home and secure with screw. For the 8' (2.4 m) diameter unit (AR8), add additional screws into the slot and through the bottom of the weir at approximately the middle, 1/4, and 3/4 positions.
19. Screw down and hand snug the nuts to the steel FRAME (G) with a wrench. Also hand snug the nuts to the top of the CYLINDER (E), and to the top of the TOP BAFFLE (C) if they have loosened. Add a drop of Threadlocker to the rod threads near each nut before final tightening.
20. Secure the top of WEIR (F) with three screws into CYLINDER (E), as shown in **figure 19**.
21. Attach Rod Caps to the top of each threaded rod, on top of the unit.
22. The finished assembly should appear as shown in **figure 20**.

**Figure 15**



**Figure 16**



**Figure 17**



**Figure 18**



**Figure 19**



**Figure 20**



## Section 3: Mounting Brackets within Concrete Manhole Riser

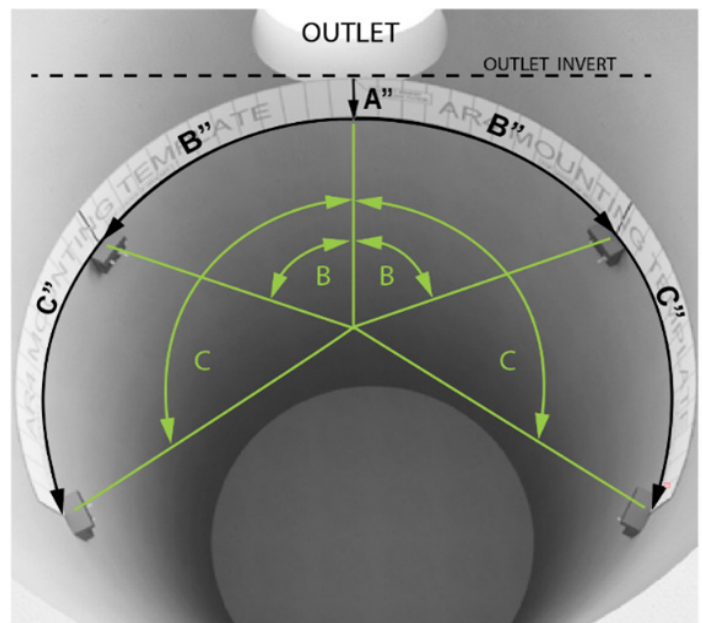
### Materials provided by ADS

- Mounting Template (Qty: 1)
- Brackets (Qty: 4)
- ¼" (6.35 mm) Diameter 20 thread size, 3 ¼" (82.55 mm) wedge anchors (Qty: 4)

### Other Tools Needed

- Drill
  - ¼" (6.35mm) Masonry drill bit
  - Hammer
  - 7/16" (11.11 mm) socket or wrench
  - Masking Tape
  - Rigging
1. Use one of the 3 methods below to locate and mark the elevation and center line for each of the 4 brackets.
    - a. Mounting Template Method:
      1. Position top of template to match the outlet pipe invert elevation.
      2. Align centerline of template with the center of the outlet pipe hole.
      3. Spread template along inner circumference of the manhole wall, maintaining level. Affix with tape as you proceed. Check level as you proceed.
      4. Mark bracket elevations and centerlines at bottom of template.
      5. Remove template.
    - b. Angular Dimensions Method:
      1. From the outlet invert, measure depth A (Table 1) and around B° and C° in each direction to locate the top of each bracket. Mark top of bracket.
    - c. Linear Dimensions Method:
      1. From the outlet invert, measure depth A (Table 2) and around the inside arc B" and C" in each direction to locate the top of each bracket. Mark top of bracket. Crosscheck outlet invert elevations from approved job specific drawings.

Figure 22



**Table 1: Angular Measurements**

Arcadia Model	A. Depth from Outlet Invert in (mm)	B. Angle from Outlet Center	C. Angle from Outlet Center
AR3	4 1/2 (114.3)	65°	115°
AR4	5 1/2 (139.7)	60°	120°
AR5	6 (150)	65°	115°
AR6	6 1/2 (165.1)	60°	120°
AR8	8 (200)	60°	120°

**Table 2: Linear Measurements**

Arcadia Model	A. Depth from Outlet Invert in (mm)	B. Measurement from Outlet Center in (mm)	C. Measurement from Outlet Center in (mm)
AR3	4 1/2 (114.3)	20 3/8 (517.5)	36 1/8 (917.6)
AR4	5 1/2 (139.7)	25 1/8 (638.1)	50 1/4 (1276.3)
AR5	6 (150)	34 (850)	60 1/8 (1527.2)
AR6	6 1/2 (165.1)	37 3/4 (958.8)	75 1/2 (1917.7)
AR8	8 (200)	50 1/4 (1276.3)	100 1/2 (2552.7)

2. Hold bracket in position in manhole at locations indicated. Mark anchor holes for each bracket as shown in **figure 23**.
3. Drill two 1/4" (6.35 mm) holes per bracket, 2 1/2" (63.5 mm) deep. Diagonal holes are recommended. Extra holes provided if needed as shown in **figure 24**.
4. Attach 4 brackets to manhole at positions marked, aligned with top of bracket. Lightly hammer the anchors in place. Tighten the locking nuts to firmly secure brackets to the concrete. Trim any excess anchor that extends beyond the bracket edge as shown in **figure 25**.
5. Extend center lines up the manhole wall to the top. Also extend lines across top edge. These center lines will be used by installers at the jobsite to align the unit during installation as shown in **figure 26**.

*Note: These center lines are part of the bracket installation and should be made with a suitable marking device that can be easily seen, such as a level and marker, or chalk line.*

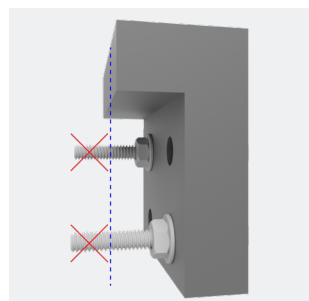
**Figure 23**



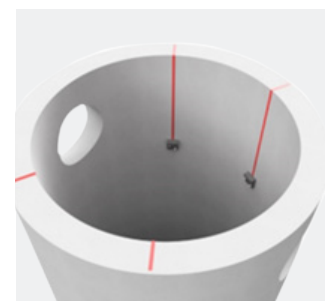
**Figure 24**



**Figure 25**



**Figure 26**



## Section 4: Transporting Assembled Arcadia Internals

Placing assembled Arcadia inside concrete manhole riser section; Most common.

1. Choosing a segment of precast concrete manhole riser or base.
  - For transport, choose a riser section that does not contain the mounting brackets, with the following minimum riser depths. This riser section will serve as shipping containment for the internals.
  - The Arcadia internals will be permanently installed onto the mounting brackets at the jobsite. See Section 5.
2. Rigging Arcadia Internals for lifting.
  - Use the stainless-steel frame arms as pick points for straps, chains or other qualified rigging. It is recommended to attach at diagonally opposite arms.
  - Appropriate rigging examples shown in **figures 27 and 28**.
3. Place Arcadia Internals within the riser segment using hoisting equipment.
4. Secure with strapping.
5. Along with the internals, be sure to also deliver the 3 additional items listed in the note below and seen in **figures 29 and 30**.

Minimum Depth Transport Riser Section ft (m)	Arcadia Model
3 (0.9)	AR3
4 (1.2)	AR4, AR5, AR6
5 (1.5)	AR8
6 (1.8)	AR10

Figure 27



Figure 28



Figure 29



Figure 30



*Note: Please deliver the following additional items to the jobsite along with the assembled Arcadia unit.*

- Small hardware package marked "Arcadia Installation, For Jobsite Contractor (NOT FOR PRECASTER)"
- Conseal roll(s)
- Copy of the Installation Guide

Transporting without a concrete riser?  
Contact ADS for guidance.

**Table 4:** Arcadia Separator Internals Weight Once Assembled

Arcadia Model	AR3	AR4	AR5	AR6	AR8	AR10
lbs (kg)	82 (37.1)	165 (74.8)	252 (411.3)	356 (161.4)	882 (400)	1306 (592.3)

## Section 5: Installing Arcadia Internals into the Manhole

These directions assume the manhole base and riser have not been assembled, and that the top slab has not been set.

Note: Do not insert the inlet or outlet pipes until after the Arcadia internals have been installed. If pipes must be inserted in advance, the pipes should not protrude into the structure as they can interfere with installation of the Arcadia Internals.

### Materials provided by ADS

- Arcadia Internals (Qty: 1)
- ¼" (6.35 mm) Diameter 20 thread count, 3 ¼" (82.55 mm) wedge anchors (Qty: 2)
- 5/16" (7.93 mm) Diameter 1 ½" (38.1 mm) hex head lag screws and washers (Qty: 4)
- ¼" (6.35 mm) high speed drill bit for drilling into steel brackets (only for AR8 model)
- Conseal Roll(s)

### Other Tools Needed

- Drill
  - ¼" (6.35 mm) Masonry Drill Bit
  - 3/16" (4.76 mm) Multi-Purpose Drill Bit
  - Hammer
  - 7/16" (11.11 mm) socket or wrench
  - Rigging
1. Before assembling the manhole base and riser(s), remove the assembled Arcadia unit from the precast segment that was used for protection during transport, if applicable. Rig the Arcadia internals for overhead lifting. Use the stainless-steel frame arms as pick points for straps, chains or other qualified rigging. It is recommended to attach diagonally to opposite arms. See **figures 31 and 32**. Set the Arcadia unit on level ground.
  2. Locate the concrete riser section with Arcadia Mounting Brackets installed.
  3. Check for bracket centerline markings inside and on top edge of the manhole. If no markings are present, find and extend the centerlines of each bracket along the inside of the riser all the way to the riser top edge as shown. These centerlines will be used to align the unit during installation. See **figure 33**.
  4. Rig Arcadia internals for overhead lifting. Use the stainless-steel frame arms as pick points for straps, chains or other qualified rigging. It is recommended to attach diagonally to opposite arms. See **figures 31 and 32**.

Figure 31



Figure 32



Figure 33

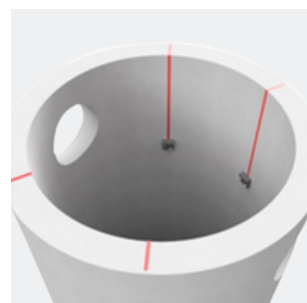
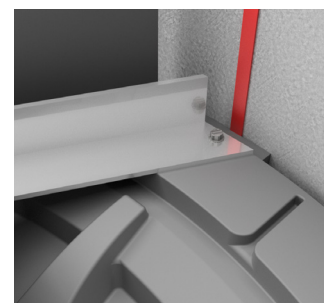


Figure 34



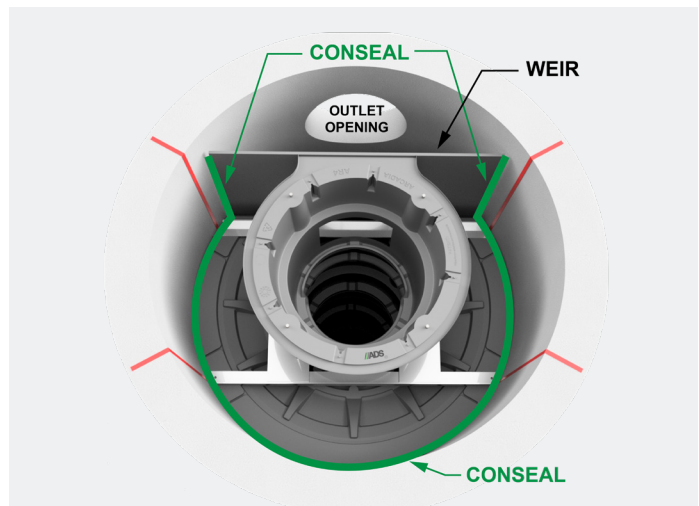
- a. Keep the WEIR (F) centered above the outlet pipe opening. See **figure 35**.
- b. Keep frame arms aligned with bracket centerlines during the entire lowering process. Failure to maintain alignment could result in damage to the unit. See **figure 36**.

5. Lift Arcadia internals at slow speed. Before lowering the unit into the manhole, check for proper alignment with the mounting brackets inside the manhole. Orientation is important throughout the entire installation process.
6. Once aligned, slowly lower Arcadia internals into manhole. Utilize a spotter to guide the alignment of the unit with tagline. Proceed until the stainless-steel frame arms are resting on the pre-installed mounting brackets within the manhole.
7. Affix Arcadia internals with provided lag screws and washers through the holes in the ends of the stainless-steel frame arms, through the top plastic of the unit and into the plastic brackets beneath. First pre-drill each with a 3/16" (4.76 mm) drill bit, or for AR8 use the provided 1/4" (6.35 mm) drill bit into steel brackets below. Use 7/16" (11.11 mm) socket to drive in lag screws until snug.
8. Affix WEIR (F) edges to manhole walls using concrete anchors. See **figures 37 and 38**.

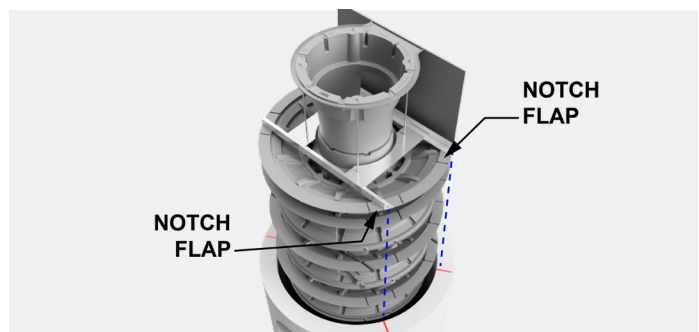
- a. Bend WEIR (F) installation tabs to the manhole wall as shown in **figure 37**.
- b. Mark holes for anchors, one hole per tab.
- c. Drill a 1/4" (6.35 mm) hole 2 1/2" (63.5 mm) deep at each marked hole.
- d. Bend WEIR (F) installation tabs to manhole wall.
- e. Insert anchors and lightly hammer in place to secure WEIR (F) to manhole wall.
- f. Tighten the locking nuts to firmly secure brackets to the manhole wall as shown in **figure 38**.

9. Finally, seal WEIR (F) & TOP BAFFLE (C) edges to manhole wall using conseal to fill any gaps. See **figure 35**.

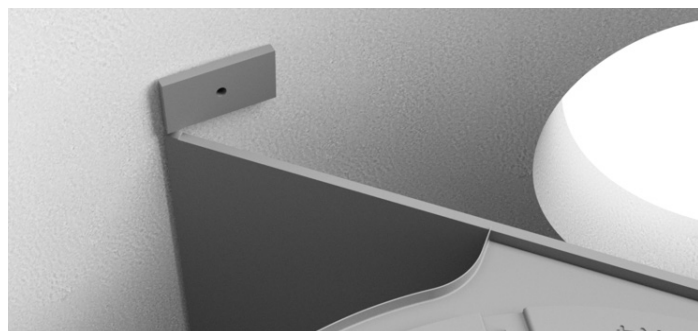
**Figure 35**



**Figure 36**



**Figure 37**



**Figure 38**

