

26-1451 - 852981 Auto Zone 9385

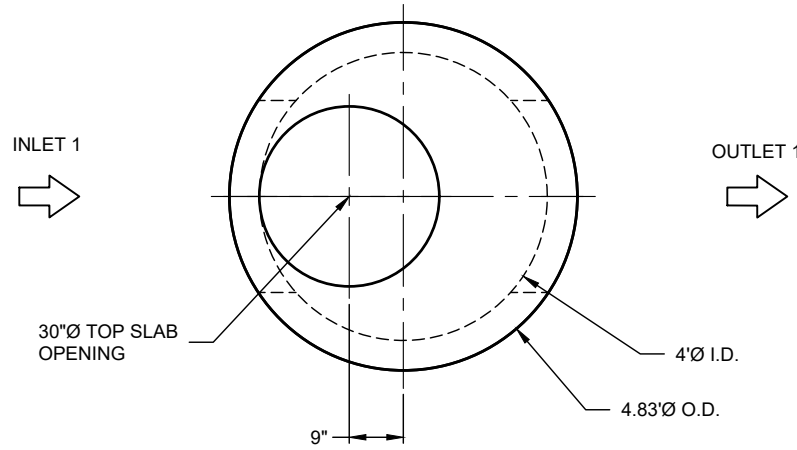

PLAN VIEW
INTERNALS NOT SHOWN

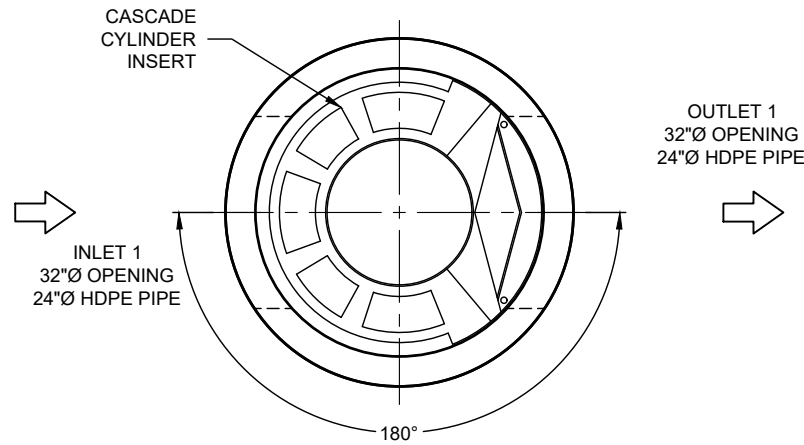

PLAN VIEW FOR PIPE ORIENTATION
TOP SLAB NOT SHOWN

10-CS-4
ICAST to fully pre-assemble internal materials prior to shipment

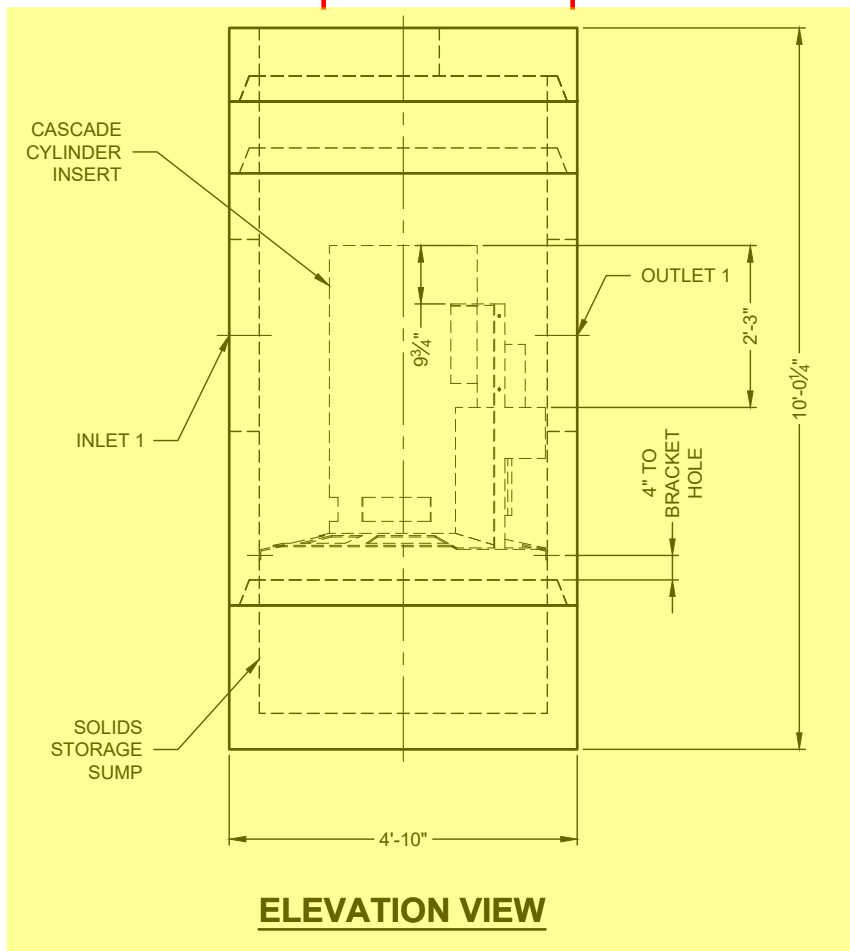

ELEVATION VIEW

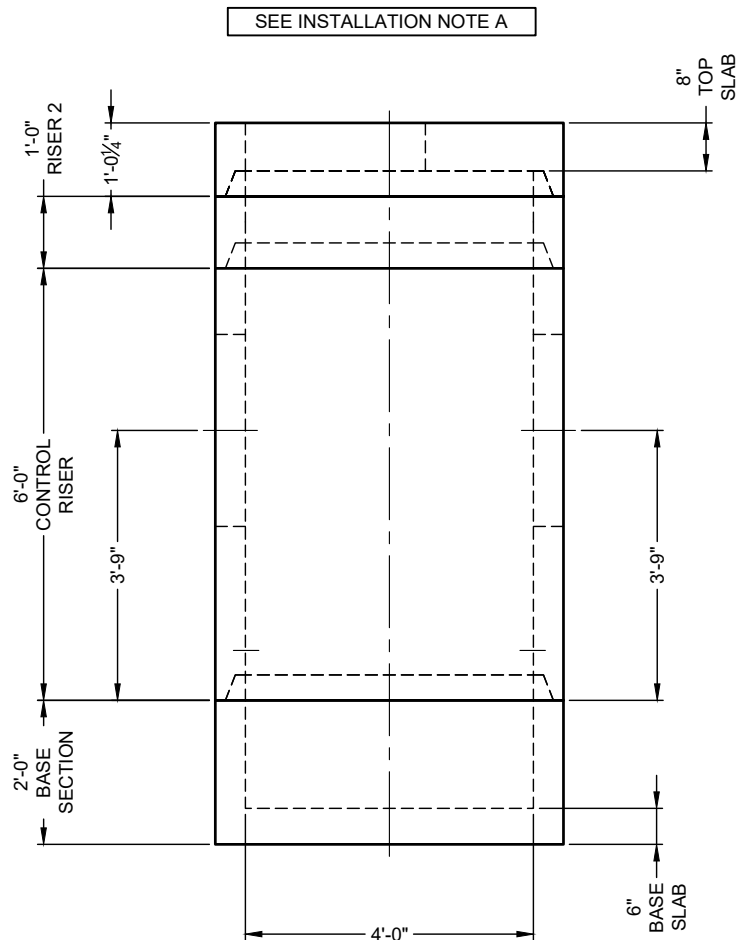

PRECAST COMPONENTS
INTERNALS NOT SHOWN

ICAST
5888 / 757440
LAYOUT 1A
4.85TS

CONTECH
FABRICATION
DRAWING

MATERIAL LIST

COUNT	DESCRIPTION	PART NUMBER	PROVIDED BY	INSTALLED BY
1	CS-4 CYLINDER INSERT, STD.	325-003949	CONTECH	PRECASTER
4	CS-4 ALUMINUM INSTALLATION BRACKETS	325-003956	CONTECH	PRECASTER
1	CS-4 HARDWARE KIT	325-003955	CONTECH	PRECASTER
1	SEALANT FOR JOINTS		PRECASTER	CONTRACTOR
1	30"Ø X 4" FRAME AND COVER, EJ #41600483, OR EQUIV.	325-000332	CONTECH	CONTRACTOR

GENERAL NOTES

- DESIGN LOADING - AASHTO HS-20
- ALL PRECAST CONCRETE MANUFACTURED PARTS SHALL CONFORM TO ASTM C-478, WITH MINIMUM CONCRETE STRENGTH OF 4000 PSI AT 28 DAYS
- JOINT SEALANT SHALL CONFORM TO ASTM C-990 OR ASTM C-443
- GROUND WATER ELEVATION ASSUMED AT OUTLET INVERT
- MANUFACTURING TOLERANCE = +/- 1/2-INCH
- SOME HIDDEN LINES MAY BE OMITTED FOR CLARITY

INSTALLATION NOTES

- PRECASTER TO SHIP ACCESS CASTINGS WITH STRUCTURE
- REFER TO CONTECH ASSEMBLY INSTRUCTIONS FOR ADDITIONAL INFORMATION.
- PRECASTER TO INSTALL INTERNAL COMPONENTS PRIOR TO SHIPPING UNLESS INSTRUCTED OTHERWISE BY CONTECH
- PIPE OPENINGS SHALL BE STENCILED "INLET" OR "OUTLET" AS APPROPRIATE
- APPLYING ALIGNMENT MARKS ON ALL PIECES OF MULTIPLE PIECE ASSEMBLIES IS ENCOURAGED
- IF STRUCTURE IS DELIVERED IN MULTIPLE SECTIONS, EACH PIECE SHALL BE LABELED WITH THE CONTECH PROJECT NUMBER, SEQUENCE NUMBER AND SITE DESIGNATION

SITE INFORMATION

RIM ELEV. = 455.5+/-
TOP OF STRUCTURE = 454.67
INLET PIPE 1 INVERT ELEV. = 449.40
INLET PIPE 1 DIAMETER AND MATERIAL = 24"Ø HDPE
OUTLET PIPE INVERT ELEV. = 449.40
OUTLET PIPE DIAMETER AND MATERIAL = 24"Ø HDPE
OUTSIDE BOTTOM OF STRUCTURE ELEV. = 444.65

STRUCTURE WEIGHT

APPROXIMATE HEAVIEST PICK = 5500 LBS.
STRUCTURE IS DELIVERED IN 4 PIECES

TOP SLAB = 2000 LBS.
RISER 2 = 1000 LBS.
CONTROL RISER = 5500 LBS.
BASE SECTION = 5500 LBS.

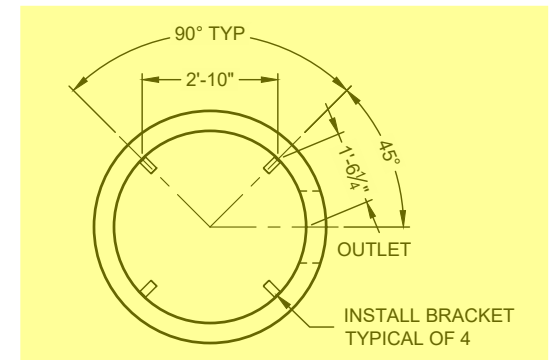

SUPPORT BRACKET LAYOUT PLAN VIEW

The design and information shown on this drawing is the property of CONTECH Construction Products Inc. or one of its affiliated companies ("CONTECH"). Neither this drawing, nor any part thereof, may be used, reproduced, or transmitted in any form or by any means, electronic or mechanical, including photocopying, recording, or by any information storage and retrieval system, without the express written consent of CONTECH. Failure to comply with these terms and conditions shall constitute a breach of contract and shall constitute a disclaimer of any liability or responsibility for such use.

If discrepancies between the supplied information upon which the drawing is based and actual field conditions are encountered as site work progresses, these are to be immediately reported to the design engineer. CONTECH shall not be held responsible for any design errors, omissions, or incomplete or inaccurate information supplied by others.

MARK	DATE	REVISION DESCRIPTION	BY

CS-4 - 852981-10
AUTO ZONE #9385
LOUISVILLE, KY
SITE DESIGNATION: SWQU 1-1

CONTECH
ENGINEERED SOLUTIONS LLC
A CONTECH COMPANY

810 Centre Pointe Dr., Suite 403, West Chester, OH 45380
800.338.1122 513.645.7000 513.665.7803 FAX

CASCADE
separator

FOR PATENT INFORMATION, GO TO www.contech.com/IP

DATE: 1/6/2025	
DESIGNED: MDB	DRAWN: MDB
CHECKED: CEU	APPROVED: MDB
PROJECT No.: 852981	SEQUENCE No.: 10
SHEET: 1	OF 1

I:\QUIKRETE.NET\CONTECH\MERLIN\PROJECTS\TACTIVE\852981\852981-10-CASCADE\EDR\DRAWINGS\852981-10-CS-4-CONFAB.DWG 2/19/2025 5:13 PM

26-1451 - 852981 Auto Zone 9385

1810B4 V1600-4 Assembly

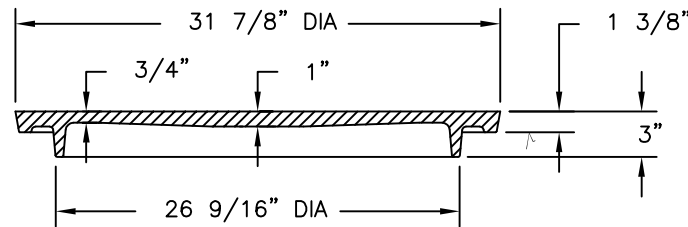
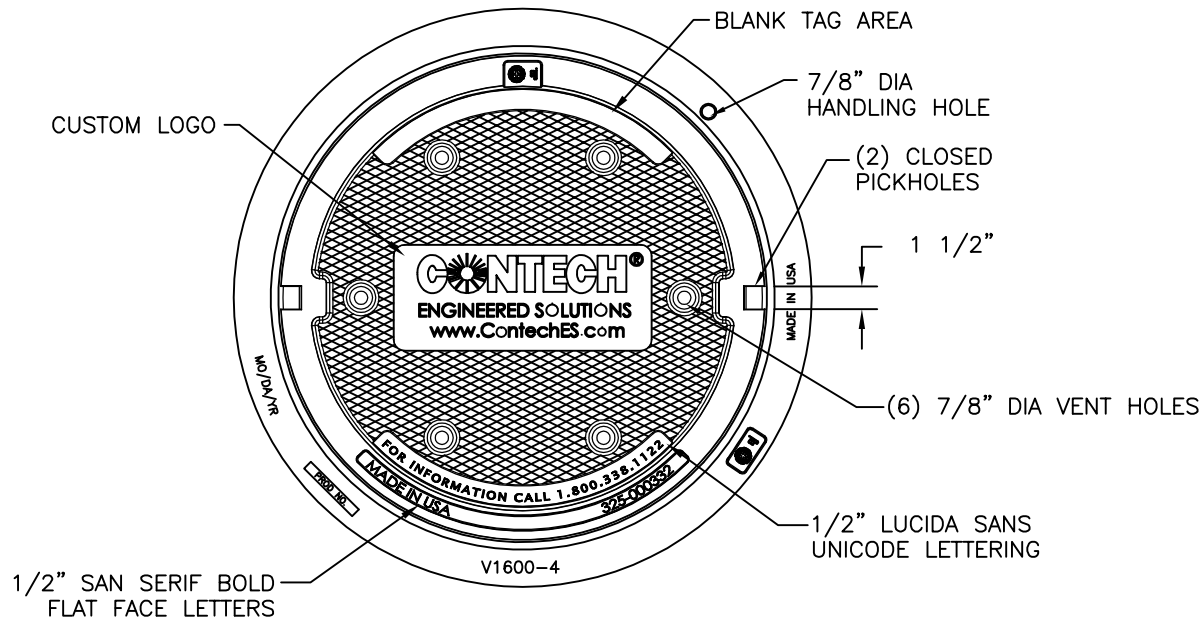

COVER SECTION

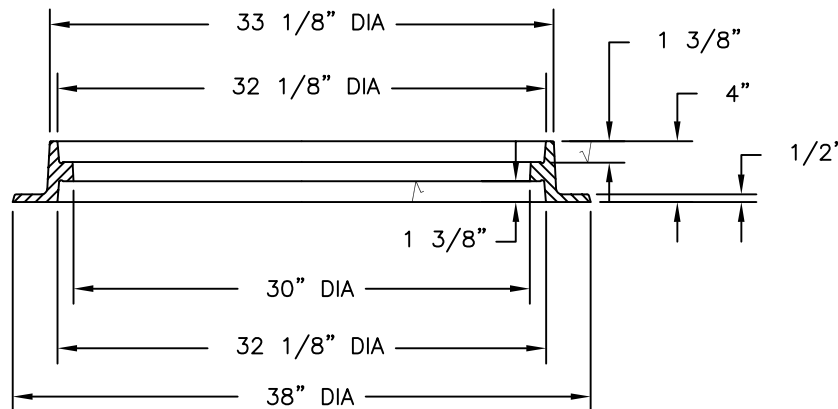

FRAME SECTION

Product Number
41600483

Design Features

- Materials
 - Cover Gray Iron (CL35B)
 - Frame Gray Iron (CL35B)

- Design Load
 - Heavy Duty
- Open Area
 - n/a
- Coating
 - Undipped
- √ Designates Machined Surface

Certification

- ASTM A48
- Country of Origin: USA

Major Components

00180783
41600410

Drawing Revision

05/09/2007 Designer: SMH
6/26/2017 Revised By: DAE

Disclaimer

Weights (lbs./kg) dimensions (inches/mm) and drawings provided for your guidance. We reserve the right to modify specifications without prior notice.

CONFIDENTIAL: This drawing is the property of EJ GROUP, Inc., and embodies confidential information, registered marks, patents, trade secret information, and/or know how that is the property of EJ GROUP, Inc. Copyright © 2012 EJ GROUP, Inc. All rights reserved.

Contact

800 626 4653
ejco.com

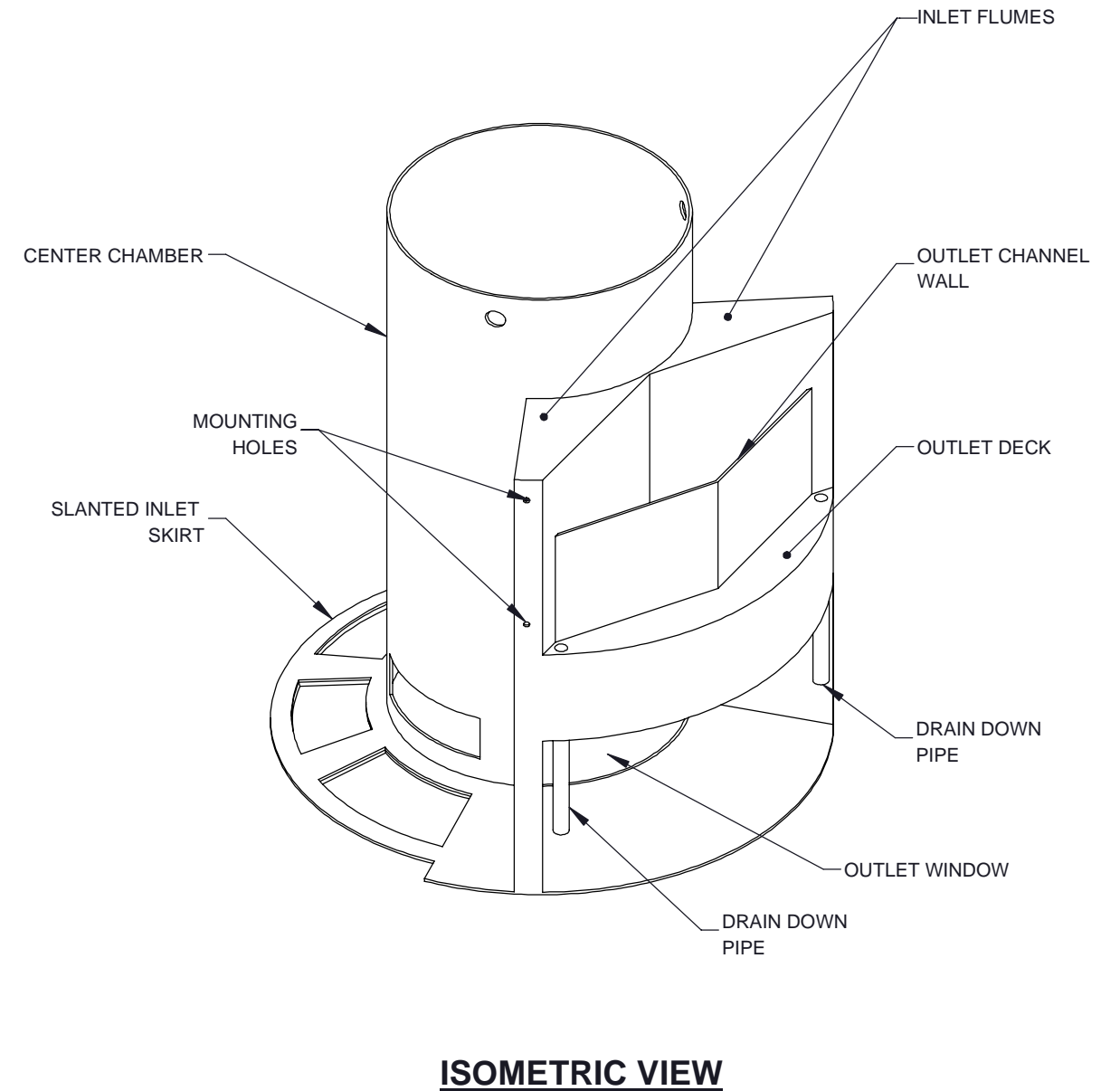
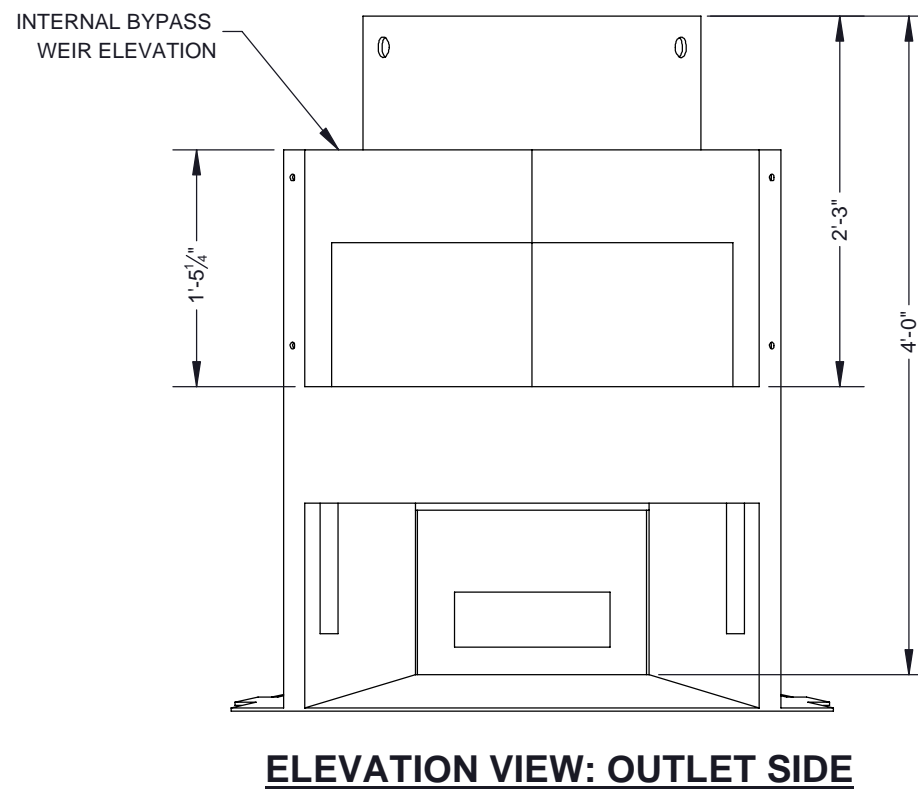
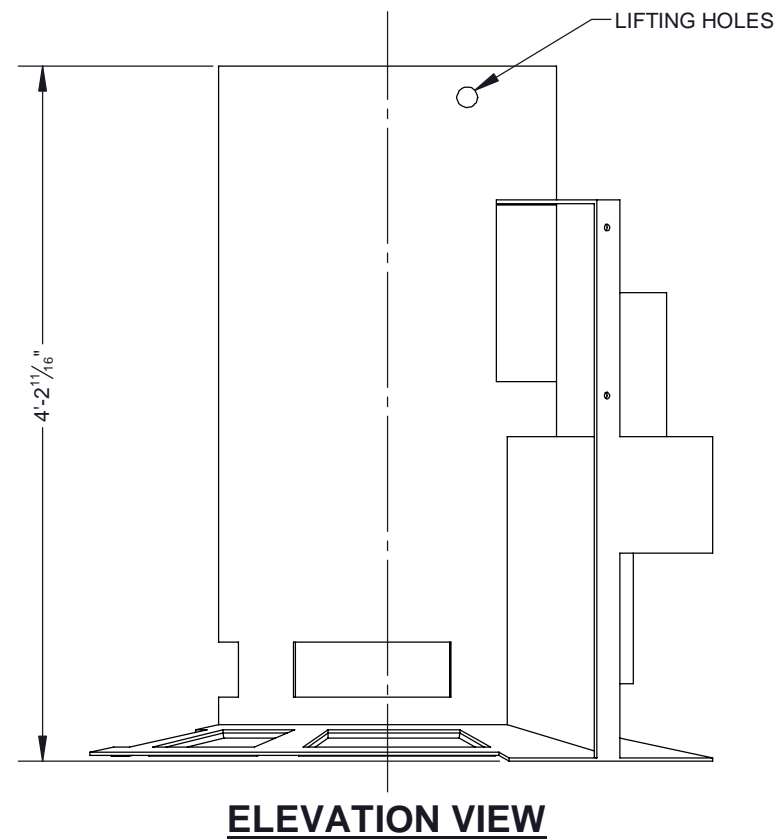
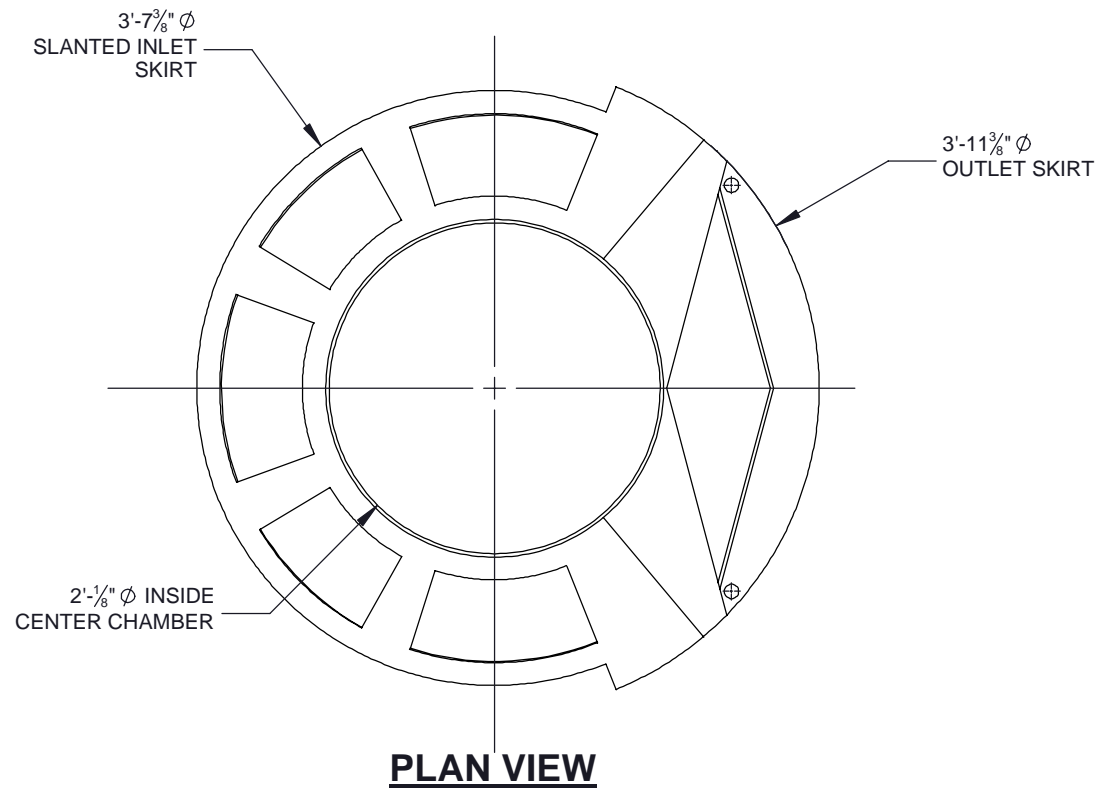

- NOTES:
 1. SEE CASCADE SEPARATOR INSTALLATION GUIDE FOR ADDITIONAL INFORMATION

The design and information shown on this drawing is provided as a service to the project owner, engineer and contractor by Contech Engineered Solutions LLC, or one of its affiliated companies ("Contech"). Neither this drawing, nor any part thereof, may be used, reproduced or modified in any manner without the prior written consent of Contech. Failure to comply is done at the user's own risk and Contech expressly disclaims any liability or responsibility for such use.

If discrepancies between the supplied information upon which the drawing is based and actual field conditions are encountered as site work progresses, these discrepancies must be reported to Contech immediately for re-evaluation of the design. Contech accepts no liability for designs based on missing, incomplete or inaccurate information supplied by others.

CASCADE
separator™

CONTECH
ENGINEERED SOLUTIONS LLC

www.ContechES.com
 9025 Centre Pointe Dr., Suite 400, West Chester, OH 45069
 800-338-1122 513-645-7000 513-645-7993 FAX

REFERENCE DETAIL
 INTERNALS CS-4
 CASCADE SEPARATOR

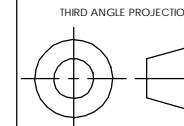

UNLESS OTHERWISE SPECIFIED
 DIMENSIONS ARE IN INCHES

TOLERANCES:
 FRACTIONAL ± 1/16
 ANGLES ± 1 DEGREE
 TWO PLACE DECIMAL ± 0.06
 THREE PLACE DECIMAL ± 0.030

PART NUMBER: 325-003949		
APPROVED BY: M. BROOKS	DRAWN BY: M. BROOKS	
APPROVED BY DATE: 2021.10.21	DRAWN BY DATE: 2021.09.14	REV: B
SCALE: N/A	SHEET 1 OF 1	