

Job Name: 26-1450 836600 South English Station
 Job Location: Louisville, KY
 Contractor: Contech Engineering Solutions

Plant: Beaver Dam
 3/2/2026 2:41:36 PM

Tech: S. Felletter
 PC: T. Sekula



Structure ID: 10-CS-5

P2 MH060RS72

MH RISER T/G

- P5) 30" - CASTING HEIGHT - 4"
- P4) 60" - MH FLAT TOP SPEC. (30" ECC HOLE) F/G - 13"
- P3) 60" - MH RISER T/G - 12"
- P2) 60" - MH RISER T/G - 72"
- P1) 60" - MH BASE T/h - 18"
- 1) CVSTENCILING
- 1) ASSEMBLY REQUIRED
- 3) 60" - Conseal CS-102 1.00"
- 3) Hole - 16

0 lb
 2589 lb
 1253 lb
 7207 lb
 4612 lb
 0 lb
 0 lb
 0 lb
 0 lb
 0 lb
 Structure Total: 15661 lb

Structure Notes:
 4" CASTING BY OTHERS
 LIFTING ANCHORS TO BE INSTALLED ON THE OUTSIDE OF THE STRUCTURE
 ICAST TO INSTALL THE INTERNALS
 CONTECH'S LOGO AS WELL AS THE INLET AND OUTLET MUST BE STENCILED ONTO THE STRUCTURE

Rim: 705.6' Rim to Invert: 6.1' Slack: 11.2" Sump: 57" Step Position:

Position	Elev	Angle	Ext. (cw)	Pipe	Pipe OD	Connector	Hole	Horz Size	Up ()	Offset
Invert 1	699.5'	270°	169.646"	12" HDPE	14.5"	Hole 16	16"	16.196"	32.25"	0"
Invert 2	699.5'	60°	37.699"	12" HDPE	14.5"	Hole 16	16"	16.196"	32.25"	0"
Invert 3	699.5'	208°	123.649"	12" HDPE	14.5"	Hole 16	16"	16.708"	32.25"	-6.996"
Invert 4										
Invert 5										
Invert 6										
Invert 7										
Invert 8										

RIGHT-SIDE UP VIEW (int. dimensions)

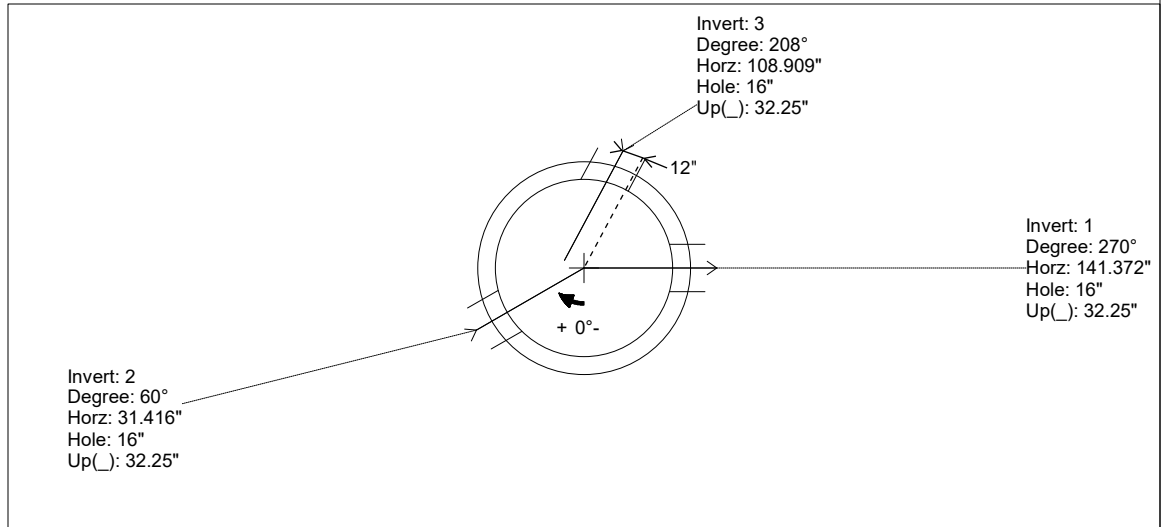
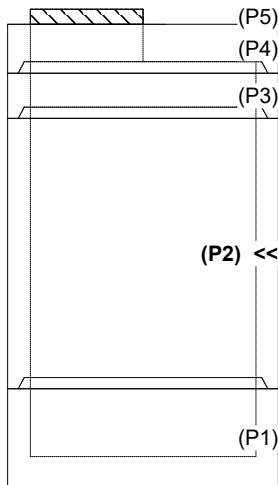

INSIDE WALL DIMENSIONS

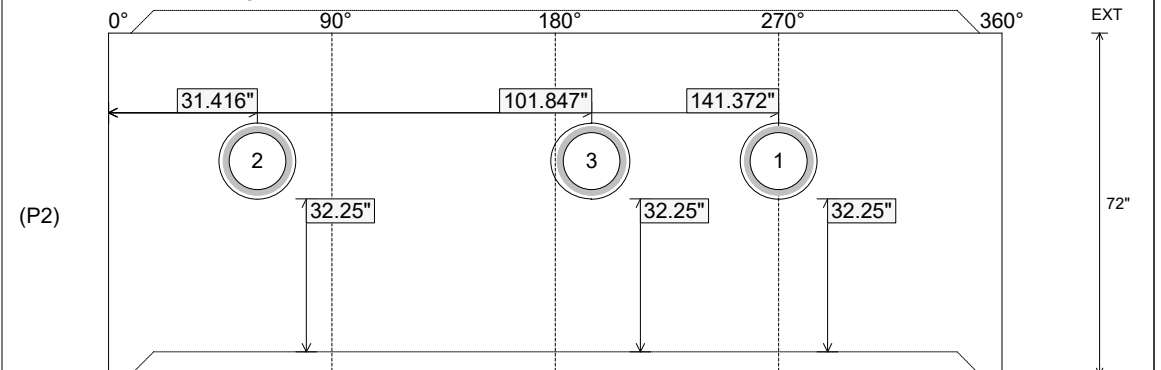

Coating (Int):
 Coating (Ext):

Seam Up: Tongue
 Seam Dn: Groove

Wall Thickness: 6"
 Floor Height: 0"

Height (Int): 72"
 Height (Ext): 72"

Weight (Net): 7207 lb
 Volume (Net): 1.84cu.yd