

Job Name: 26-1423 - JBI Office
 Job Location: Evansville, IN 47725
 Contractor: JBI Construction

Plant: 100

3/30/2026 2:51:25 PM

Tech: Jared - A

PC: Andy Chambers



Structure ID: CI-502-3 ST-CI

P1 BX2436-06BVF

BOX BASE 6inW, 6inF, Variable Ht F/n

- P2) 24" x 36" - CASTING HEIGHT - 4"
- P1) 24" x 36" - BOX BASE 6inW, 6inF, Variable Ht F/n - 55"
- 1) CASTING - HOE 525 LV SET (F/G/H)
- 1) 24" x 36" - Conseal CS-102 1.00"
- 2) Hole - 22
- 1) Hole - 10

0 lb
 4415 lb
 442 lb
 0 lb
 0 lb
 0 lb

 Structure Total: 4857 lb

- Structure Notes:**
1. PER ASTM C-913 SPECIFICATIONS
 2. CONCRETE: 4,000 PSI AT 28 DAYS
 3. REINFORCEMENT: #5 BAR @ 12" C.C. E.W. (GRADE 60) - 2" MIN. REBAR CLEARANCE (TYP)
 4. NO STORM INVERT
 5. NO STEPS
 6. HOE-525-LV FRAME, L-VANE GRATE, & CURB HOOD SUPPLIED BY ICAST
 7. INVERT 3 OFFSET 13" FROM CENTER OF WALL

Rim: 415' Rim to Invert: 4.77' Slack: 0.49" Sump: 2.25" Step Position:

| Position | Elev | Angle | Ext. (cw) | Pipe | Pipe OD | Connector | Hole | Horz Size | Up () | Offset |
|----------|---------|-------|-----------|----------------|---------|-----------|------|-----------|--------|--------|
| Invert 1 | 410.23' | 0° | 18" | 15" RCP B WALL | 19.5" | Hole 22 | 22" | 22" | 0" | 0" |
| Invert 2 | 410.23' | 120° | 27.5" | 15" RCP B WALL | 19.5" | Hole 22 | 22" | 25.403" | 0" | -6" |
| Invert 3 | 410.86' | 270° | 37" | 6" ADS N-12 | 6.9" | Hole 10 | 10" | 10" | 9.375" | 13" |
| Invert 4 | | | | | | | | | | |
| Invert 5 | | | | | | | | | | |
| Invert 6 | | | | | | | | | | |
| Invert 7 | | | | | | | | | | |
| Invert 8 | | | | | | | | | | |

RIGHT-SIDE UP VIEW (int. dimensions)

UPSIDE-DOWN VIEW (int. dimensions)

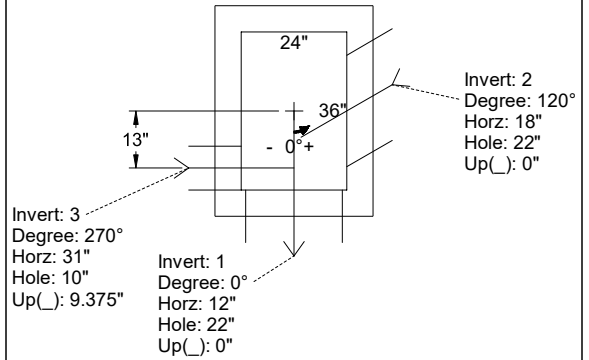
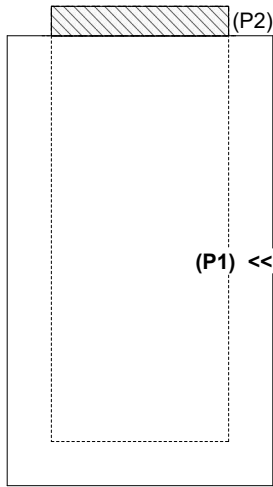

INSIDE WALL DIMENSIONS

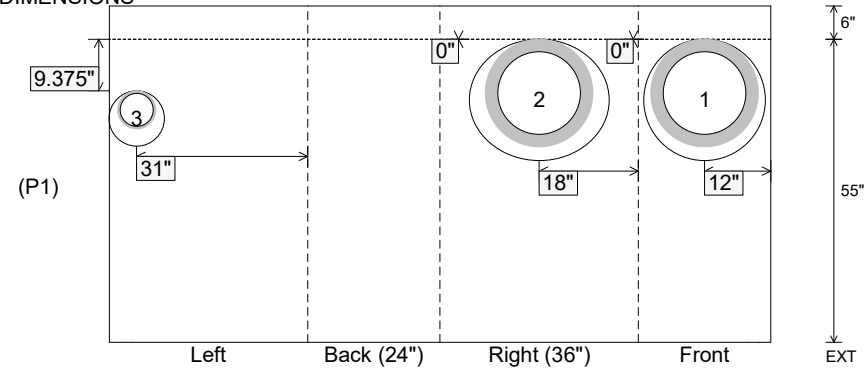

| | | | | |
|----------------------------------|-------------------------------|--|--|--|
| Coating (Int): Coating (Ext): | Seam Up: Flat Seam Dn: n/a | Wall Thickness: 6" Floor Height: 6" | Height (Int): 55" Height (Ext): 61" | Weight (Net): 4415 lb Volume (Net): 1.13cu.yd |
|----------------------------------|-------------------------------|--|--|--|