

981 W. 7th Street  
 Beaver Dam, KY 42320  
 270-363-2234

Structure: Meter MH  
 Job Number:  
 Job Name: 12th Street Vault  
 Job Location:

infrastructure precast, inc.

Specification: 72" Storm Base w/ANY  
 Contractor:

Based on:

Take Off By: 11/30/2018 Nathan

<b>Design Build Height</b>		<b>Stack Build Height</b>		<b>Manufacture Date:</b>	
Top of Casting	+ 100.00'	Eccentric Slab	+ 1.25'	<b>Ship Date:</b>	
Floor Elevation	- 93.75'	Base	+ 5.00'	<b>Hatch:</b>	36"x36" USF Hatch
<b>Design Height</b>	= <b>6.25'</b>	<b>Design Height</b>	= <b>6.25'</b>	<b>Grate/Cover:</b>	
		Floor Thickness	+ 0.00'	<b>Channel:</b>	No Channel
		<b>Outside Height</b>	= <b>6.25'</b>	<b>Coating:</b>	
				<b>Notes:</b>	

**Openings**

ID	To/From	Invert	Pipe Size	Connector	Hole Size	Hole Ref.	Angle	Dist.
#1		95.75' CL	2" PVC Schd 80	Mortar	8.00" Ø	20.0"	0°	0"
#2		95.75' CL	4" Ductile Iron	Mortar	8.00" Ø	20.0"	0°	0"
#3		95.75' CL	4" Ductile Iron	Mortar	8.00" Ø	20.0"	180°	9'-5" 1/8
#4		95.75' CL	2" PVC Schd 80	Mortar	8.00" Ø	20.0"	180°	9'-5" 1/8

**Elevation (View A-A)**

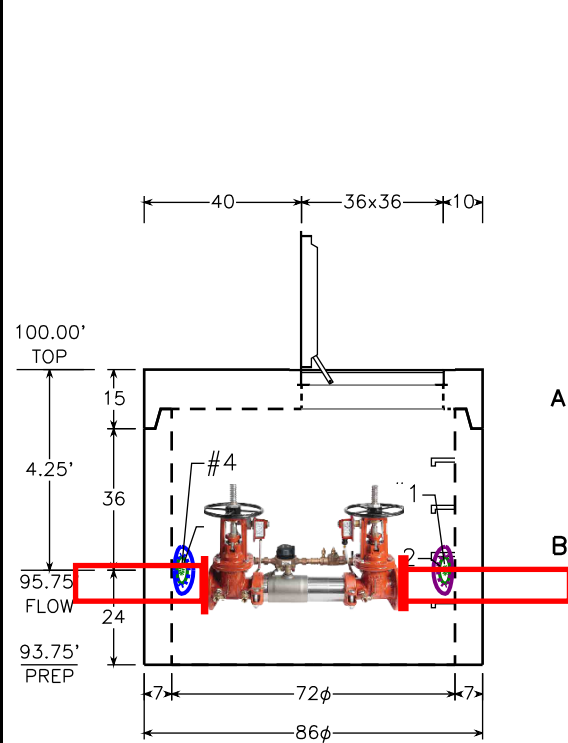

**Plan View**

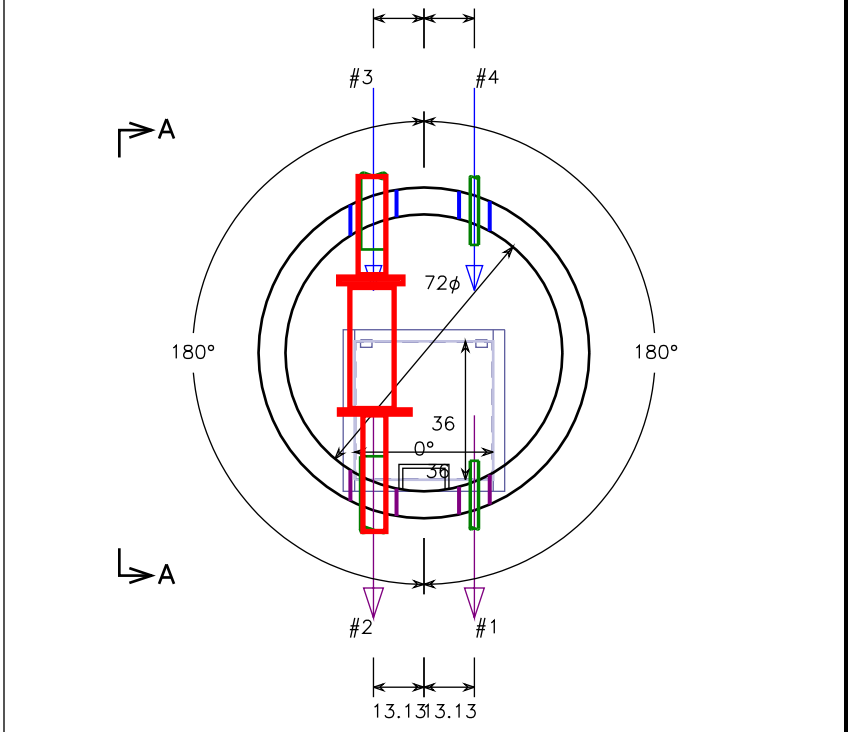

**BOM For Stack**

ID	Description	Qty.	Weight
Fr	36"x36" USF Hatch (Cast into top piece)	1	
	Step	4	
	Joint Seal 72" CS-102B	1	
A	72" Flat Top 36x36 Ecc 10T 15.0H w/36"x36" USF Hatch	1	4,394
B	72" Mono Base 0F 60.0H	1	9,069
<b>Totals (precast, lbs)</b>		<b>2</b>	<b>13,463</b>

**"Special Note Concerning Section Heights**  
 Section Heights subject to vary from information shown on BOM for Stack due to availability of Riser Inventory at the time of order placement or requested delivery date by the Customer."

# SERIES S1R ACCESS DOOR



www.HallidayProducts.com  
 Phone 800-298-1027  
 Fax 407-298-4534  
 Sales@HallidayProducts.com

## STANDARD FEATURES:

- AUTO-LOCK T-316 STAINLESS STEEL HOLD OPEN ARM WITH RELEASE HANDLE
- T-316 STAINLESS STEEL HINGES AND ATTACHING HARDWARE
- NON-CORROSIVE PADLOCK BAR
- SINGLE LEAF CONSTRUCTION
- 300 LBS. PER SQ. FT. LOAD RATING (1464 KG. PER SQ. METER LOAD RATING)
- EXTRUDED ALUMINUM FRAME
- RECESSED LIFTING HANDLE
- LIFETIME GUARANTEE

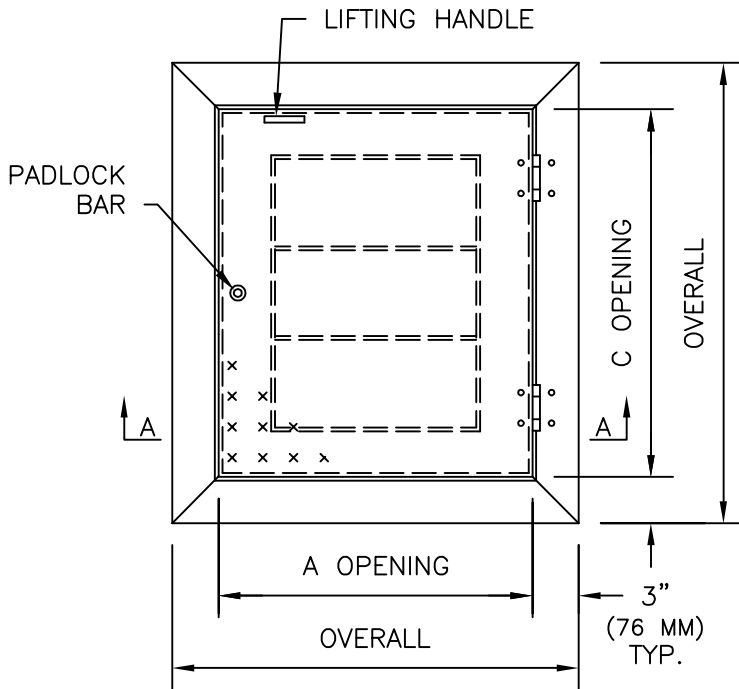

STANDARD SIZES				
QTY.	MODEL NO.	A DIM. INCHES (MM)	C DIM. INCHES (MM)	UNIT WT. LBS. (KG.)
	S1R2424	24 (610)	24 (610)	37 (17)
	S1R2430	24 (610)	30 (762)	42 (19)
	S1R2436	24 (610)	36 (914)	48 (22)
	S1R2442	24 (610)	42 (1067)	55 (25)
	S1R2448	24 (610)	48 (1219)	61 (28)
	S1R3030	30 (762)	30 (762)	49 (22)
	S1R3036	30 (762)	36 (914)	57 (26)
	S1R3042	30 (762)	42 (1067)	64 (29)
	S1R3048	30 (762)	48 (1219)	71 (32)
	S1R3054	30 (762)	54 (1372)	79 (36)
	S1R3060	30 (762)	60 (1524)	87 (39)
	S1R3636	36 (914)	36 (914)	65 (25)
	S1R3642	36 (914)	42 (1067)	79 (36)
	S1R3648	36 (914)	48 (1219)	85 (39)
	S1R3654	36 (914)	54 (1372)	91 (41)
	S1R3660	36 (914)	60 (1524)	100 (45)
	S1R3666	36 (914)	66 (1676)	109 (49)
	S1R3672	36 (914)	72 (1829)	116 (53)
	S1R4242	42 (1067)	42 (1067)	93 (42)

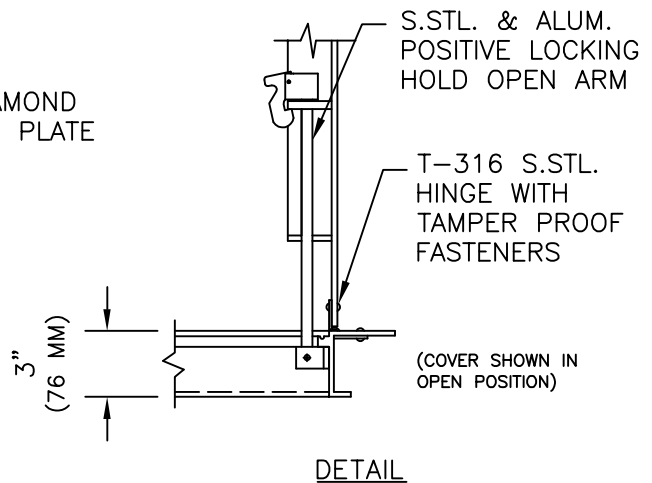
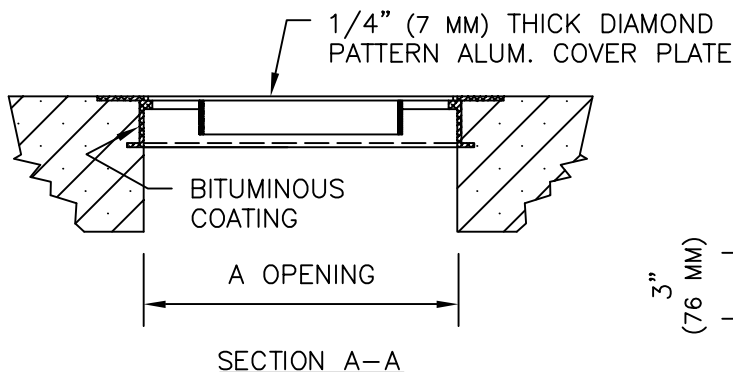

## Engineering Specification

Job Name \_\_\_\_\_

Contractor \_\_\_\_\_

Job Location \_\_\_\_\_

Approval \_\_\_\_\_

Engineer \_\_\_\_\_

Contractor's P.O. No. \_\_\_\_\_

Approval \_\_\_\_\_

Representative \_\_\_\_\_

# Series C300, C300N

## Double Check Detector Assemblies

2½" – 10"

Series C300 and C300N Double Check Detector assemblies are designed to protect drinking water supplies from dangerous cross-connections in accordance with national plumbing codes and water authority requirements for non-potable service applications such as irrigation, fire line, or industrial processing. These assemblies may be installed under continuous pressure service and may be subjected to backpressure for non-toxic applications. The series is used primarily on fire line sprinkler systems when it is necessary to monitor unauthorized use of water, and are for use in non-health hazard applications. The OS&Y model includes an option for an integrated supervisory switch on each gate valve.

### Features

- Extremely compact design
- 70% Lighter than traditional designs
- 304 (Schedule 40) Stainless steel housing & sleeve
- Groove fittings allow integral pipeline adjustment
- Patented Tri-Link Check provides lowest pressure loss
- Unmatched ease of serviceability
- Available with grooved butterfly valve shutoffs
- May be used for horizontal, vertical or N pattern installations
- Replaceable check disc rubber
- Includes an integrated supervisory switch as an option on each gate valve of the OS&Y model

### ⚠ WARNING

It is illegal to use this product in any plumbing system providing water for human consumption, such as drinking or dishwashing, in the United States. Before installing standard material product, consult your local water authority, building and plumbing codes.

### NOTICE

The information contained herein is not intended to replace the full product installation and safety information available or the experience of a trained product installer. You are required to thoroughly read all installation instructions and product safety information before beginning the installation of this product.

Inquire with governing authorities for local installation requirements.



C300-BFG



C300-OSY with supervisory switches

### Specification

The Colt C300, C300N Double Check Detector assemblies shall consist of two independent Tri-Link Check modules within a single housing, sleeve access port, four test cocks, and two drip tight shutoff valves. Tri-Link Check shall be removable and serviceable, without the use of special tools. The housing shall be constructed of 304 (Schedule 40) stainless steel pipe with groove end connections. Tri-Link Checks shall have reversible elastomer discs and in operation shall produce drip tight closure against the reverse flow of liquid caused by backpressure or backsiphonage. The bypass assembly shall consist of a meter, which registers in either gallon or cubic measurement, a double check valve assembly, and required test cocks.

The integrated supervisory tamper switch, an option on the OS&Y model, shall have continuity with the valve fully open and activate within two (2) turns from open. The device consists of two SPDT switches and is designed to send a tamper signal when the valve is closed and when the switch is removed from the valve. In the neutral position, the switch indicates the valve is fully open. Closing the valve causes the switch rod to come out of the valve stem groove, activating the switch. Removing the tamper switch also activates the switch. Assembly shall be a Colt C300, C300N as manufactured by Ames Fire & Waterworks.

Ames Fire & Waterworks product specifications in U.S. customary units and metric are approximate and are provided for reference only. For precise measurements, please contact Ames Fire & Waterworks Technical Service. Ames Fire & Waterworks reserves the right to change or modify product design, construction, specifications, or materials without prior notice and without incurring any obligation to make such changes and modifications on Ames Fire & Waterworks products previously or subsequently sold.



## Configurations

- Horizontal
- Vertical up
- “N” pattern horizontal

## Materials

Housing & Sleeve	304 (Schedule 40) stainless steel
Elastomers	EPDM, silicone, and Buna ‘N’
Tri-Link Checks	Noryl®, stainless steel
Check Discs	Reversible silicone or EPDM
Test Cocks	Lead Free* bronze body
Pins & Fasteners	300 Series stainless steel
Springs	Stainless steel

## Model/Option

OSY	UL Classified and FM Approved outside stem and yoke resilient seated gate valves
TS-OSY	Integrated supervisory switch (UL Certified, Safety Signaling, Control No. 3L38) on outside stem and yoke resilient seated gate valve
BFG	UL Classified and FM Approved grooved gear operated butterfly valves with tamper switch
OSY FxG**	Flanged inlet gate connection and grooved outlet gate connection
OSY GxF**	Grooved inlet gate connection and flanged outlet gate connection
OSY GxG**	Grooved inlet gate connection and grooved outlet gate connection

## Pressure – Temperature

Temperature Range: 33°F – 140°F (0.5°C – 60°C)  
 Maximum Working Pressure: 175 psi (12.1 bar)

## Dimensions – Weights

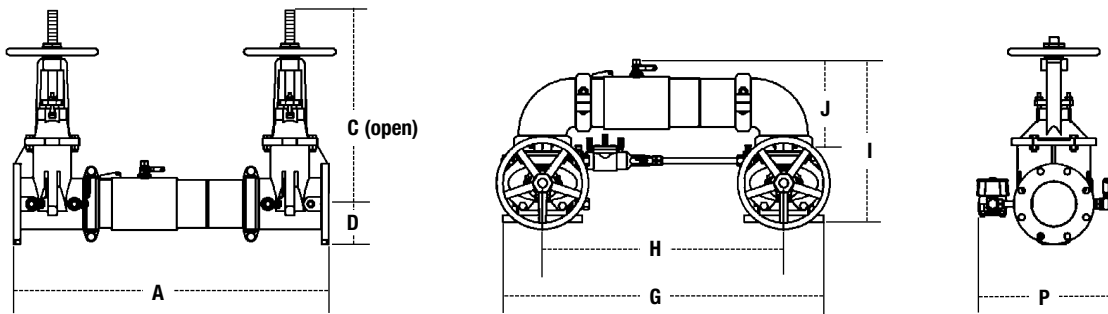

### C300, C300N

SIZE	DIMENSIONS												WEIGHT							
	A		C (OSY)		D		G		H		I		J		P		C300		C300N	
in.	in.	mm	in.	mm	in.	mm	in.	mm	in.	mm	in.	mm	in.	mm	in.	mm	lb	kg	lb	kg
2½	30¾	781	16⅞	416	3½	89	29⅞	738	21½	546	15½	393	8⅜	223	13⅞	335	144	65	152	69
3	31¾	806	18⅞	479	3⅞	94	30¼	768	22¼	565	17⅞	435	9⅜	233	14½	368	164	74	177	80
4	33¾	857	22¾	578	4	102	33	838	23½	597	18½	470	9⅝	252	15⅞	386	180	81	203	92
6	43½	1105	30⅞	765	5½	140	44¾	1137	33¼	845	23⅞	589	13⅞	332	19	483	314	142	355	161
8	49¾	1264	37¾	959	6⅞	170	54⅞	1375	40⅞	1019	27⅞	697	15⅞	399	21⅞	538	499	226	574	260
10	57¾	1467	45¾	1162	8⅞	208	66	1676	49½	1257	32½	826	17⅞	440	24	610	800	363	970	440

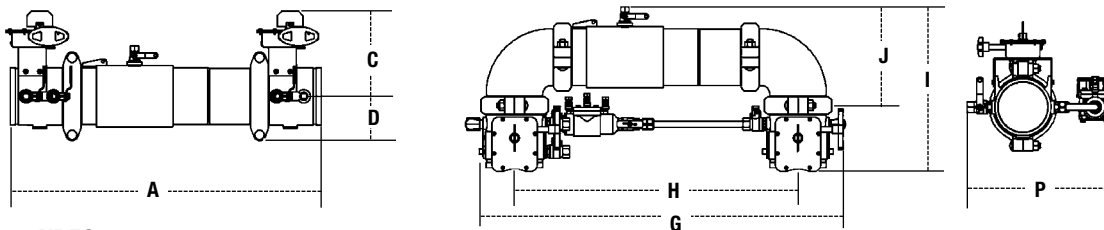

### C300BFG, C300NBFG

SIZE	DIMENSIONS												WEIGHT							
	A		C		D		G		H		I		J		P		C300BFG		C300NBFG	
in.	in.	mm	in.	mm	in.	mm	in.	mm	in.	mm	in.	mm	in.	mm	in.	mm	lb	kg	lb	kg
2½	27¾	705	8	203	3½	89	29⅞	759	21½	546	14⅝	379	8⅜	223	13	330	70	32	78	35
3	28¼	718	8⅝	211	3⅞	94	30⅞	779	22¼	565	15⅞	392	9⅜	233	13½	343	68	31	81	37
4	29	737	8⅝	227	3⅞	94	31⅝	811	23½	597	16¼	412	9⅝	252	14	356	75	34	98	44
6	36½	927	10	254	5	127	43⅞	1097	33¼	845	19⅞	500	13⅞	332	14½	368	131	59	171	78
8	42¾	1086	12¼	311	6½	165	51⅞	1297	40⅞	1019	23⅞	592	15⅞	399	18⅞	462	275	125	351	159

Noryl is a registered trademark of SHPP Global Technologies B.V.

\*\* Consult factory for the following: Grooved NRS gate valves, post indicator plate and operating nut, dimensions

# Approvals

- Approved by the Foundation for Cross-Connection Control and Hydraulic Research at The University of Southern California (FCCCHR-USC)
- AWWA C510-97

For additional approval information, contact the factory or check Ames Fire & Waterworks at watts.com.



Flow capacity chart identifies valve performance based upon rated water velocity up to 25 fps.

- Service Flow is typically determined by a rated velocity of 7.5 fps based upon Schedule 40 pipe.
- Rated Flow identifies maximum continuous duty performance determined by AWWA.
- UL Flow Rate is 150% of Rated Flow and is not recommended for continuous duty.
- AWWA Manual M22 (Appendix C) recommends that the maximum water velocity in services be not more than 10 fps.

## Capacity

UL and FM Certified Flow Characteristics  
Flow characteristics collected using butterfly shutoff valves

—— Horizontal    —— Vertical    - - - - - N-Pattern

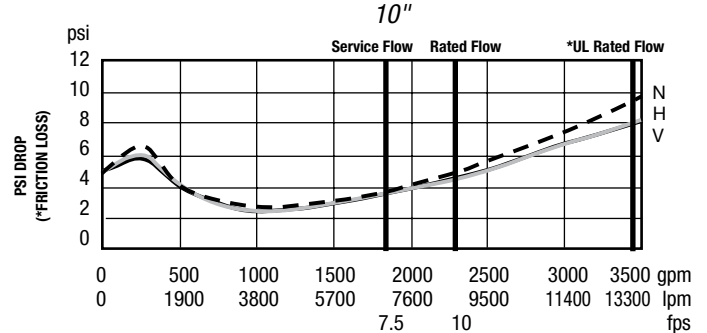
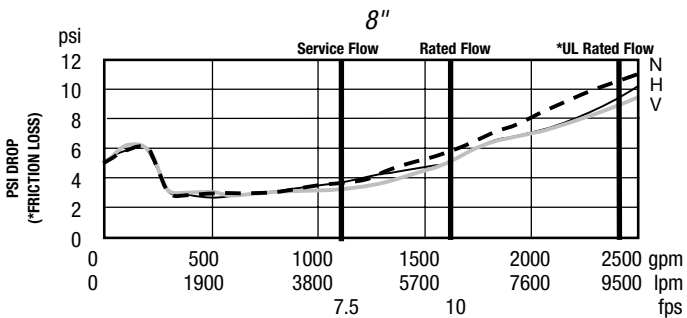
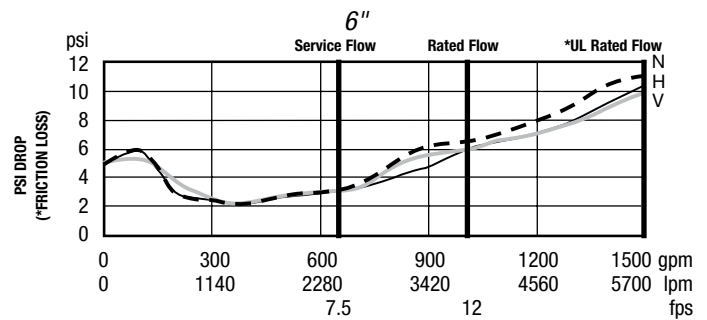
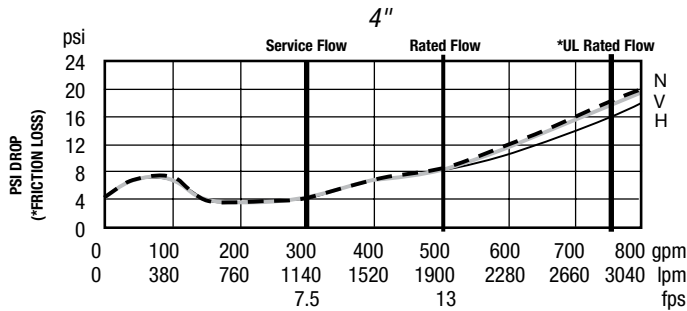
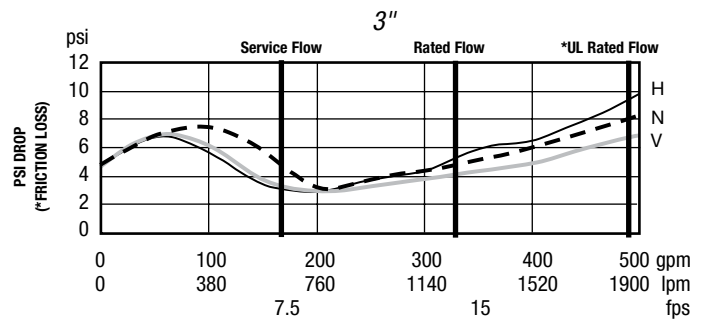
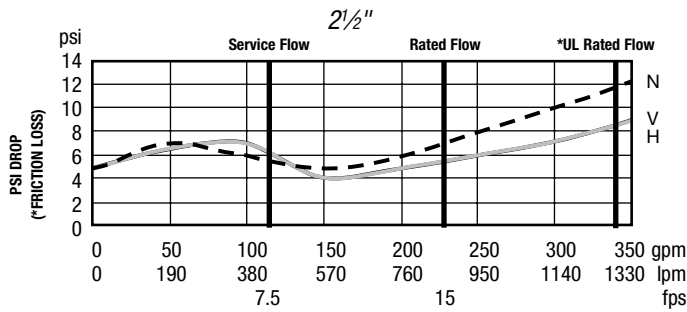

A WATTS Brand

USA: Backflow T: (978) 689-6066 • AmesFireWater.com  
 USA: Control Valves T: (713) 943-0688 • AmesFireWater.com  
 Canada: T: (888) 208-8927 • AmesFireWater.ca  
 Latin America: T: (52) 55-4122-0138 • AmesFireWater.com