

Job Name: 26-1393 - Dry Run WWTP Material
 Job Location: Shelbyville, KY 40601
 Contractor: Smith Contractors, Inc.

Plant: 100
 3/12/2026 7:45:04 PM

Tech: Jared - F
 PC: E. Bradley



Structure ID: PS-8-5 SS-MH

P1 MH048BA24

MH BASE T/n

P4) 24" - CASTING HEIGHT - 7"

P3) 24" - GRADE RING F/F - 4"

P2) 48" - MH FLAT TOP w/ 24" ECC Hole F/G - 12"

P1) 48" - MH BASE T/n - 24"

1) JOINT WRAP - 0.065"x6"x50' CONSEAL CS212

1) JOINT WRAP PRIMER - CONSEAL CS-75 (1 gal.)

1) 48" - MH INVERT CHANNEL - FULL HEIGHT

1) CASTING - HOE MC-350 F/C Sanitary

1) 48" - Conseal CS-102 1.00" (Double)

3) PSX - 12M NYLO

1) PSX - 8QRS-S NYLO

0 lb
 270 lb
 1561 lb
 2842 lb
 0 lb
 0 lb
 1440 lb
 305 lb
 0 lb
 24 lb
 6 lb

 6448 lb

Structure Total: 6448 lb

Structure Notes:

1. PER ASTM C478 SPECIFICATIONS.
2. CONCRETE = 4,000 PSI AT 28 DAYS.
3. NO STEPS.
4. CASTING BY ICAST (HOE MC-350 F/C SANITARY).

REINFORCING PER ASTM A615 (GRADE 60).
 - TOP SLAB = H2O LOADING.
 - RISER/WALLS (As .12)
 - FLOOR (As .31) #5 BARS AT 12" C.C.E.W.

Rim: 730.62' Rim to Invert: 3.81' Slack: 0.72" Sump: 2" Step Position:

Position	Elev	Angle	Ext. (cw)	Pipe	Pipe OD	Connector	Hole	Horz Size	Up ()	Offset
Invert 1	726.81'	0°	0"	8" DI	9"	PSX 12M NYLO	12"	12.129"	0"	0"
Invert 2	727'	90°	45.5"	8" DI	9"	PSX 12M NYLO	12"	12.129"	2.25"	0"
Invert 3	726.88'	180°	91.125"	8" DI	9"	PSX 12M NYLO	12"	12.129"	0.875"	0"
Invert 4	727'	135°	68.375"	4" DI	4.75"	PSX 8QRS-S NYLO	8"	8.038"	2.25"	0"
Invert 5										
Invert 6										
Invert 7										
Invert 8										

RIGHT-SIDE UP VIEW (int. dimensions)

UPSIDE-DOWN VIEW (int. dimensions)

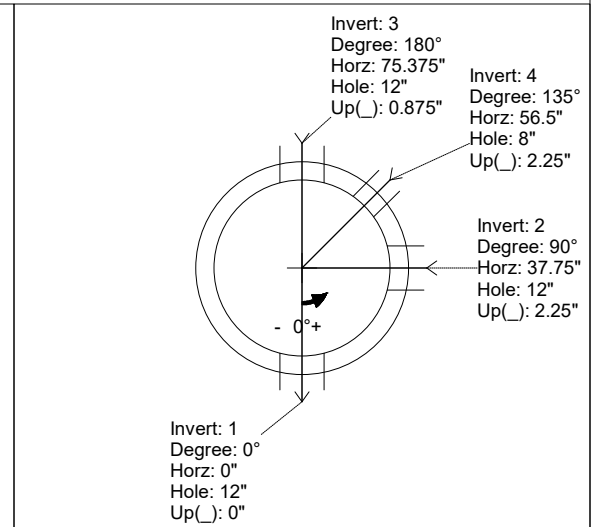
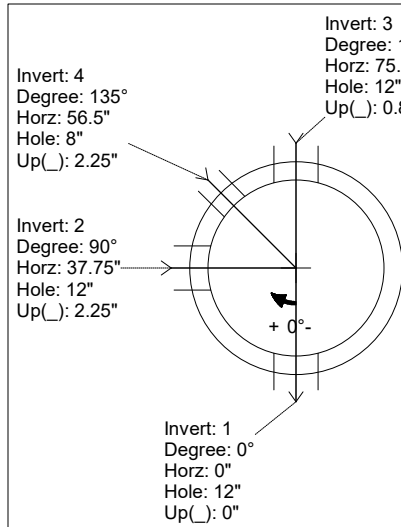
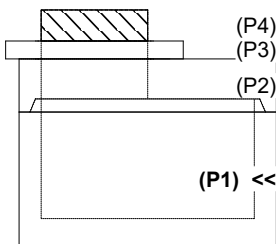

INSIDE WALL DIMENSIONS

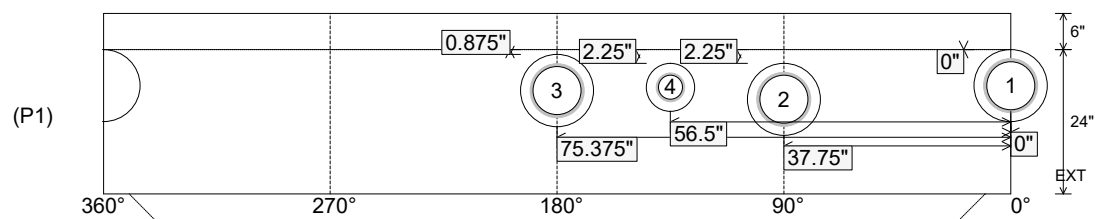

Coating (Int):
 Coating (Ext):

Seam Up: Tongue
 Seam Dn: n/a

Wall Thickness: 5"
 Floor Height: 6"

Height (Int): 24"
 Height (Ext): 30"

Weight (Net): 2842 lb
 Volume (Net): 0.73cu.yd

Job Name: 26-1393 - Dry Run WWTP Material
 Job Location: Shelbyville, KY 40601
 Contractor: Smith Contractors, Inc.

Plant: 100
 3/12/2026 7:45:04 PM

Tech: Jared - F
 PC: E. Bradley



Structure ID: PS-8-5 SS-MH

P1 MH048BA24

MH BASE T/n

- P4) 24" - CASTING HEIGHT - 7"
- P3) 24" - GRADE RING F/F - 4"
- P2) 48" - MH FLAT TOP w/ 24" ECC Hole F/G - 12"
- P1) 48" - MH BASE T/n - 24"
- 1) JOINT WRAP - 0.065"x6"x50' CONSEAL CS212
- 1) JOINT WRAP PRIMER - CONSEAL CS-75 (1 gal.)
- 1) 48" - MH INVERT CHANNEL - FULL HEIGHT**
- 1) CASTING - HOE MC-350 F/C Sanitary
- 1) 48" - Conseal CS-102 1.00" (Double)
- 3) PSX - 12M NYLO
- 1) PSX - 8QRS-S NYLO

0 lb
 270 lb
 1561 lb
 2842 lb
 0 lb
 0 lb
 1440 lb
 305 lb
 0 lb
 24 lb
 6 lb

 Structure Total: 6448 lb

Structure Notes:
 1. PER ASTM C478 SPECIFICATIONS.
 2. CONCRETE = 4,000 PSI AT 28 DAYS.
 3. NO STEPS.
 4. CASTING BY ICAST (HOE MC-350 F/C SANITARY).

 REINFORCING PER ASTM A615 (GRADE 60).
 - TOP SLAB = H2O LOADING.
 - RISER/WALLS (As .12)
 - FLOOR (As .31) #5 BARS AT 12" C.C.E.W.

Rim: 730.62' Rim to Invert: 3.81' Slack: 0.72" Sump: 2" Step Position:

Position	Elev	Angle	Ext. (cw)	Pipe	Pipe OD	Connector	Hole	Horz Size	Up ()	Offset
Invert 1	726.81'	0°	0"	8" DI	9"	PSX 12M NYLO	12"	12.129"	0"	0"
Invert 2	727'	90°	45.5"	8" DI	9"	PSX 12M NYLO	12"	12.129"	2.25"	0"
Invert 3	726.88'	180°	91.125"	8" DI	9"	PSX 12M NYLO	12"	12.129"	0.875"	0"
Invert 4	727'	135°	68.375"	4" DI	4.75"	PSX 8QRS-S NYLO	8"	8.038"	2.25"	0"
Invert 5										
Invert 6										
Invert 7										
Invert 8										

RIGHT-SIDE UP VIEW (int. dimensions)

UPSIDE-DOWN VIEW (int. dimensions)

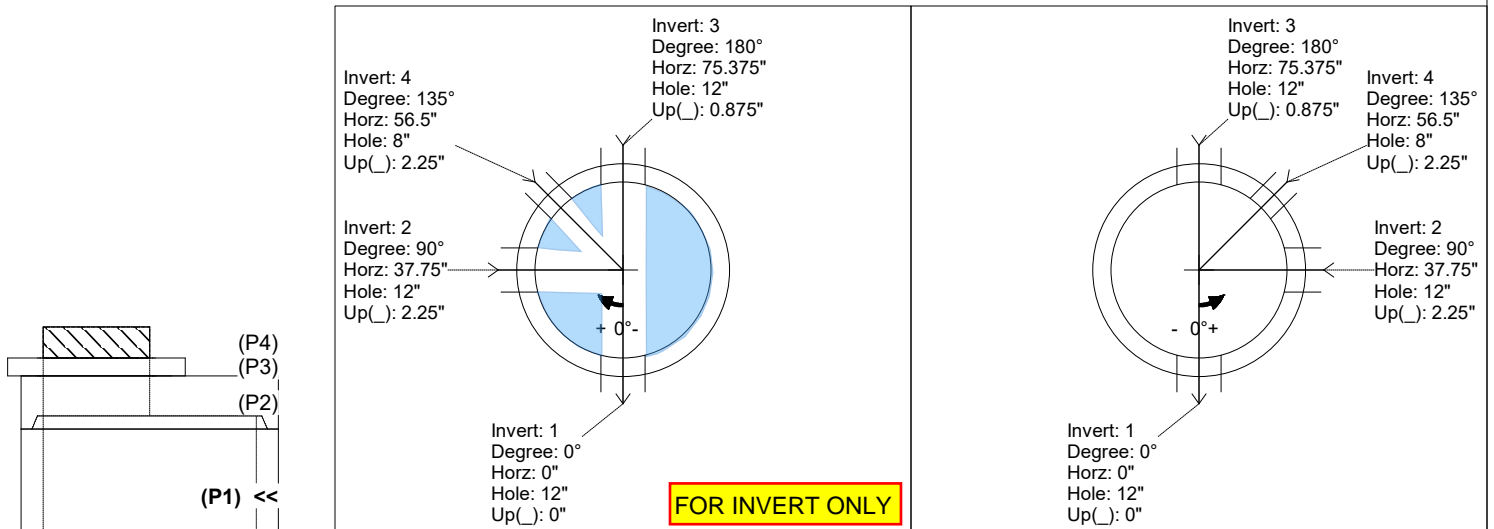

INSIDE WALL DIMENSIONS

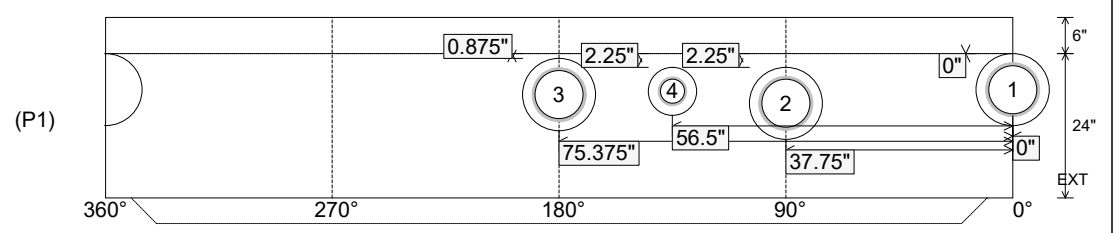

Coating (Int): Coating (Ext):	Seam Up: Tongue Seam Dn: n/a	Wall Thickness: 5" Floor Height: 6"	Height (Int): 24" Height (Ext): 30"	Weight (Net): 2842 lb Volume (Net): 0.73cu.yd
----------------------------------	---------------------------------	--	--	--