

Job Name: 26-1370 833973 Cedar Creek Connector  
 Job Location: Louisville, KY  
 Contractor: Contech Engineering Solutions

Plant: Beaver Dam  
 3/12/2026 9:48:30 AM

Tech: S. Felletter  
 PC: T. Sekula



**Structure ID: 15-CS-4**

**P2 MH048RS60**

**MH RISER T/G**

- P5) 30" - CASTING HEIGHT - 4"
- P4) 48" - MH FLAT LID w/30in ECC Hole F/G - 12"
- P3) 48" - MH RISER T/G - 12"
- P2) 48" - MH RISER T/G - 60"
- P1) 48" - MH BASE T/h - 18"
- 1) CVSTENCILING
- 1) ASSEMBLY REQUIRED
- 3) 48" - Conseal CS-102 1.00"
- 2) Hole - 20

0 lb  
 1413 lb  
 838 lb  
 3853 lb  
 2588 lb  
 0 lb  
 0 lb  
 0 lb  
 0 lb  
 -----  
 Structure Total: 8693 lb

**Structure Notes:**  
 4" CASTING BY OTHERS  
 LIFTING ANCHORS TO BE INSTALLED ON THE OUTSIDE OF THE STRUCTURE  
 ICAST TO INSTALL THE INTERNALS  
 CONTECH'S LOGO AS WELL AS THE INLET AND OUTLET MUST BE STENCILED ONTO THE STRUCTURE

Rim: 684.75' Rim to Invert: 4.8' Slack: 2.6" Sump: 51" Step Position:

| Position | Elev    | Angle | Ext. (cw) | Pipe     | Pipe OD | Connector | Hole | Horz Size | Up ( ) | Offset |
|----------|---------|-------|-----------|----------|---------|-----------|------|-----------|--------|--------|
| Invert 1 | 679.95' | 0°    | -13.48"   | 16" HDPE | 18"     | Hole 20   | 20"  | 27.739"   | 26.75" | -13"   |
| Invert 2 | 679.95' | 0°    | 13.48"    | 16" HDPE | 18"     | Hole 20   | 20"  | 27.739"   | 26.75" | 13"    |
| Invert 3 |         |       |           |          |         |           |      |           |        |        |
| Invert 4 |         |       |           |          |         |           |      |           |        |        |
| Invert 5 |         |       |           |          |         |           |      |           |        |        |
| Invert 6 |         |       |           |          |         |           |      |           |        |        |
| Invert 7 |         |       |           |          |         |           |      |           |        |        |
| Invert 8 |         |       |           |          |         |           |      |           |        |        |

**RIGHT-SIDE UP VIEW (int. dimensions)**

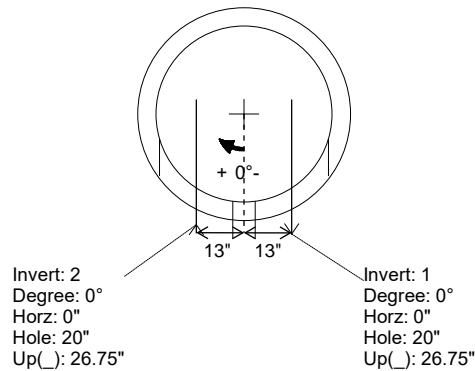
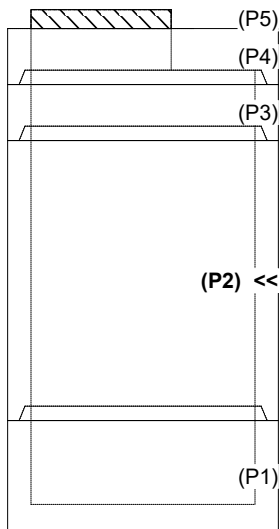

**INSIDE WALL DIMENSIONS**

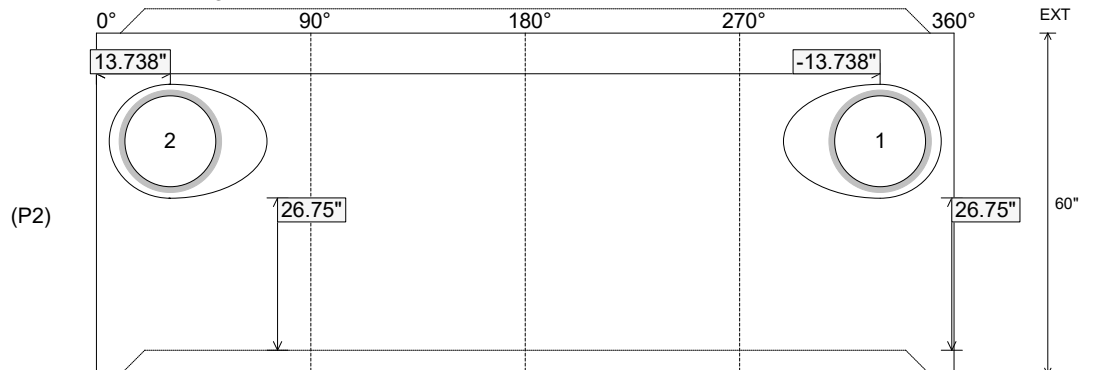

Coating (Int):  
 Coating (Ext):

Seam Up: Tongue  
 Seam Dn: Groove

Wall Thickness: 5"  
 Floor Height: 0"

Height (Int): 60"  
 Height (Ext): 60"

Weight (Net): 3853 lb  
 Volume (Net): 0.98cu.yd