

THIS DRAWING IS INTENDED TO BE PRINTED IN COLOR.

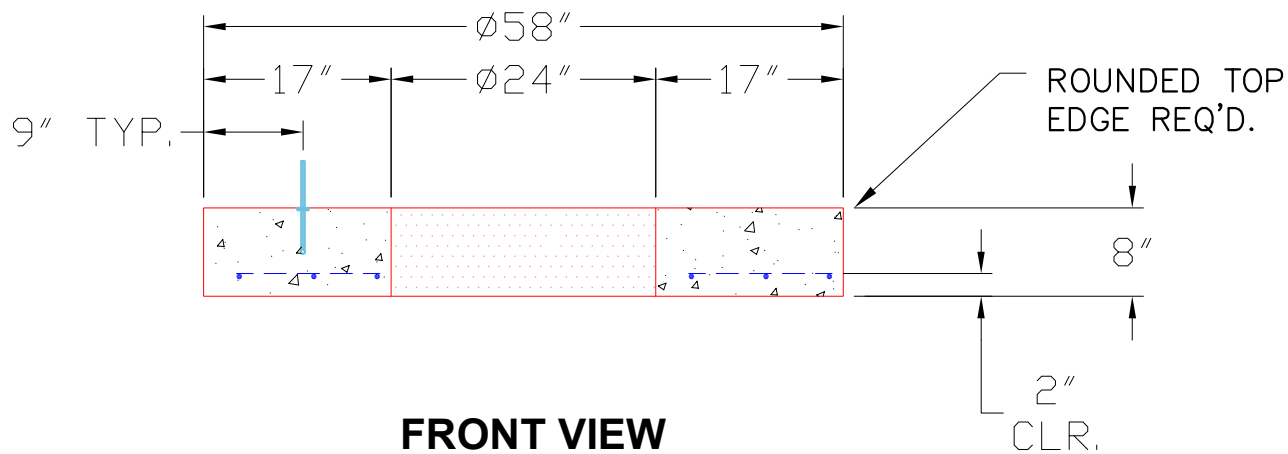
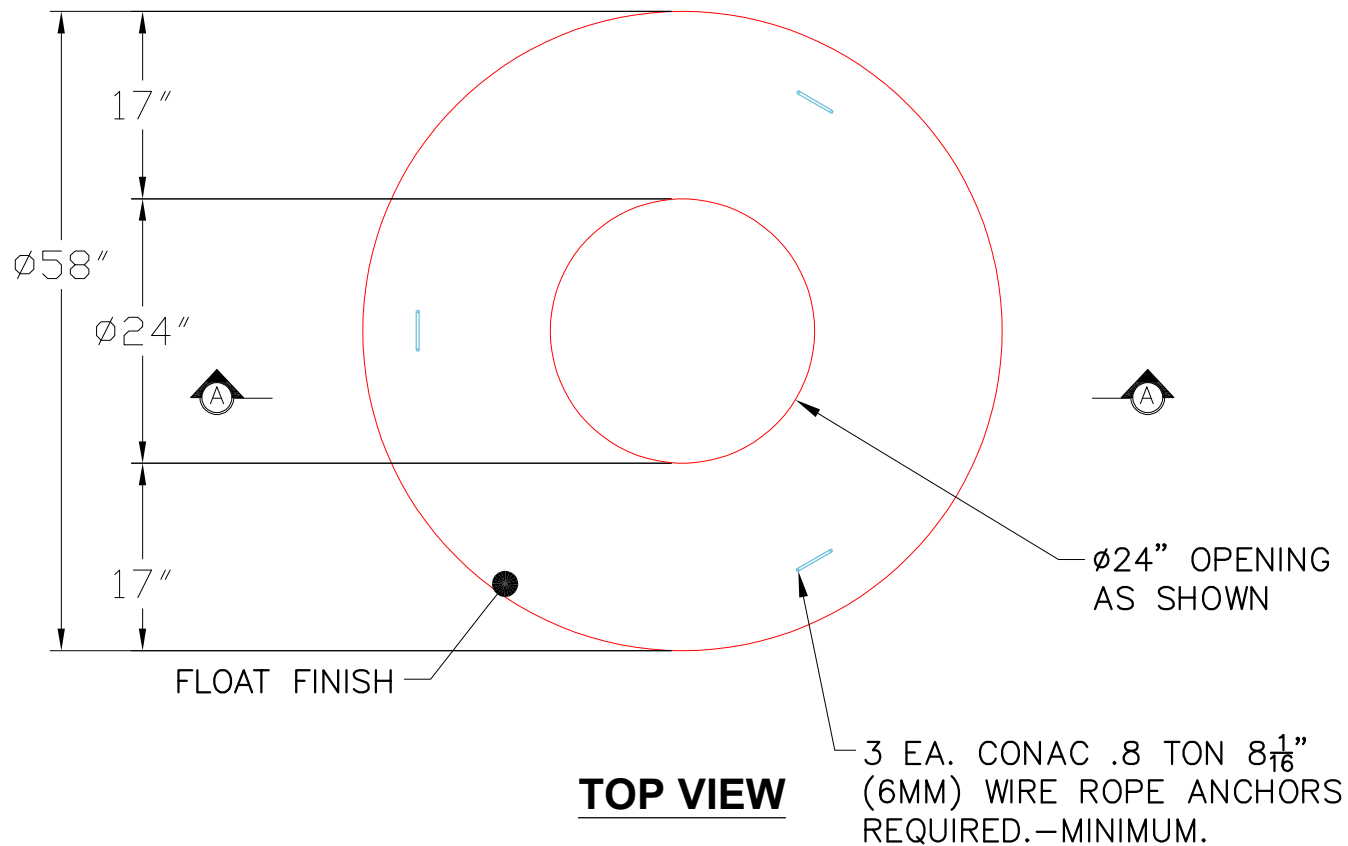

**NOTES:**

1. MANUFACTURED TO ASTM C-478 (LATEST REVISION).
2. CONCRETE: 5,000 PSI AT 28 DAYS.
3. REINFORCING: #4 BAR @ 9" O.C. E.W. (GRADE 60).

<b>PRODUCTION WORK ORDER</b>		PRODUCT I.D.: MH06LD08CC	DESCRIPTION: 48"ø X 8" MH TOP SLAB W/ ø24" CONCENTRIC OPENING	
	<b>QUALITY CONTROL CHECKLIST</b>		PRODUCT VIEW: RIGHT SIDE UP	
	<input type="checkbox"/> ALL DIMENSIONS CORRECT.		CUSTOMER: ADS ADVANCED DRAINAGE SYSTEMS, INC.	
	<input type="checkbox"/> LIFTERS INSTALLED.		PLANT: BEAVER DAM, KY.	
	<input type="checkbox"/> HOLE LOCATION CORRECT.		PROJECT: COFFEE CO RURAL OIL COLLECTION FACILITY	
	<input type="checkbox"/> REINFORCING CORRECT.		STRUCTURE: 2 TOP SLAB	
<input type="checkbox"/> FINISH ON SLAB SURFACE UNIFORM.		TOP SECTION JOINT: N/A		
<input type="checkbox"/> QUOTE/SALES ORDER NO: 26-1362		QUOTE/SALES ORDER NO: 26-1362		
<input type="checkbox"/> OUTSIDE TOP EDGE TROWELLED.		BASE SECTION JOINT: N/A		
<input type="checkbox"/> PC: C. GOFF		DRAWING: S. FELLETTA		
<input type="checkbox"/> FLAT BOTTOM.		QC CHECK INITIALS:		
DATE: 02/20/26		SCALE: NTS		
PG. 1 of 1				