

# Arcadia™ Hydrodynamic Separator Installation Guide

## AR10 Specific instructions

### Concrete Manhole Installation

This installation guide is a reference for installing the Arcadia Water Quality unit into a precast concrete structure. These directions assume the manhole base and riser have been assembled, and that the top slab has not been set.

*Note: Do not insert the inlet or outlet pipes until after the Arcadia internals have been installed. All pipes should sit flush inside the manhole. If pipes must be inserted in advance, the pipes should not protrude into the structure as they can interfere with installation of the Arcadia Internals.*

### Content

**Section 1:** Internal Components, Hardware, & Tools

**Section 2:** Baffle Pre-assembly

**Section 2A:** Small Baffle (A)

**Section 2B:** Large Spoked Baffle (B)

**Section 2C:** Top Baffle (C)

**Section 3:** Assembling Internal Components

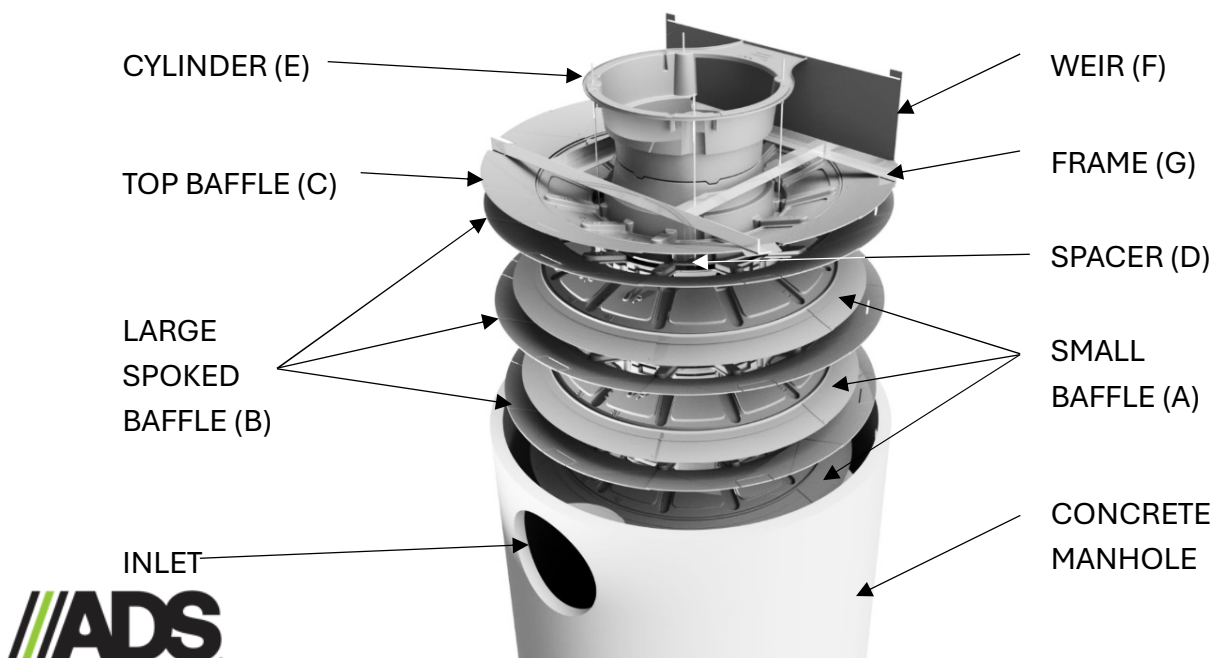
**Section 3A:** Rigging and Safety Methods

**Section 3B:** Assembling Internals

**Section 4:** Mounting Brackets within Concrete Manhole Riser

**Section 5:** Transporting Assembled Arcadia Internals

**Section 6:** Installing Arcadia Internals into the Manhole – For Contactor/Jobsite



# Section 1: Internal Components, Hardware and Tools



**SMALL BAFFLE (A)**  
Qty:3



**LARGE SPOKED BAFFLE (B)**  
Qty: 3



**TOP BAFFLE (C)**  
Qty: 1



**SPACER (D)**  
Qty: 1



**CYLINDER (E)** Qty: 1



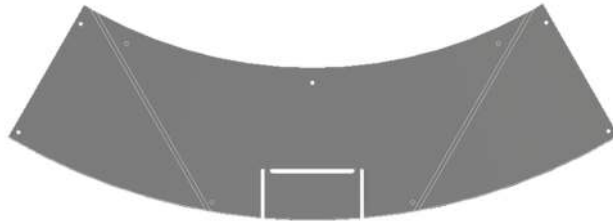
**WEIR (F)** Qty: 1



**FRAME (G)** Qty: 1



**10" wide plate QTY: 18**



**16" wide plate QTY: 23**

*Note: To separate baffles in shipping stack, pull from center of each baffle.*

## Hardware Provided by ADS



**Threaded Rod**  
(4 long and 4 short) Qty: 8



**Washers**  
Qty: 12



**Nuts**  
Qty: 12



**Threaded Coupling**  
Qty: 4



**Screws**



**Bolts for Frame Assembly**



**Rod Caps**  
Qty:4



**Threadlocker Capsules**  
Qty: 2



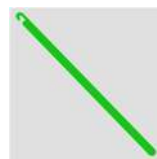
**Bolts for plates And baffles**  
Qty: 130



**Nuts**  
Qty: 130



**Washers**  
Qty: 260



**All-Thread Alignment Tool**  
QTY:2

**Please set aside the following items that will later be delivered to the jobsite along with the assembled Arcadia Unit.**

- Small Hardware package marked “Arcadia Installation, For Jobsite Contractor (Not for Precaster).”
- Conseal Roll(s).
- Copy of the Installation Guide

**Other Tools Needed**

- $\frac{9}{16}$ " (14.28 mm) or  $\frac{3}{4}$ " (19.05 mm) Hand Wrench, depending on model size
- 7/16" wrench and socket
- Phillips screwdriver or screw gun with Phillips bit
- Drill and  $\frac{5}{16}$ " , and  $\frac{1}{2}$ " drill bit
- 14 long lifting straps, guy ropes, or any appropriate lifting equipment

## Section 2: Baffle Pre-Assembly

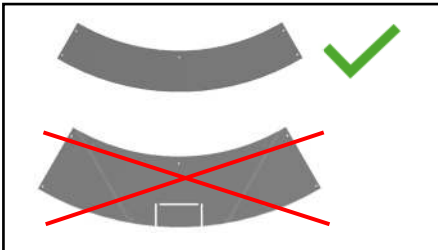
### 2A: Small Baffle (A)

1. Place small baffle on ground with small “UP” (circled) letters reading correctly (Figure 1). Note the location of the weir slot (line). You will need to assemble 3 of these baffles.

Note: Ignore backwards “UP” on these baffles at this time.

2. Get one of the small plates (Figure 2) (10” wide, no flap cutout). The hole numbers in Figure 2 will be referred to in the following steps.

Note: Ignore backwards “UP” on these baffles at this time.



3. Starting opposite the weir slot, place the small plate in the recessed area. There is a registration mark (circled) on the baffle to help you align the center. It is near the manufactured date wheels on the part. Align Hole 2 with the registration mark (Figure 3).

4. The entire plate should be centered in the recessed portion of the baffle. Push and bend the plate to match the baffle edge. (Figure 4)

Figure 1

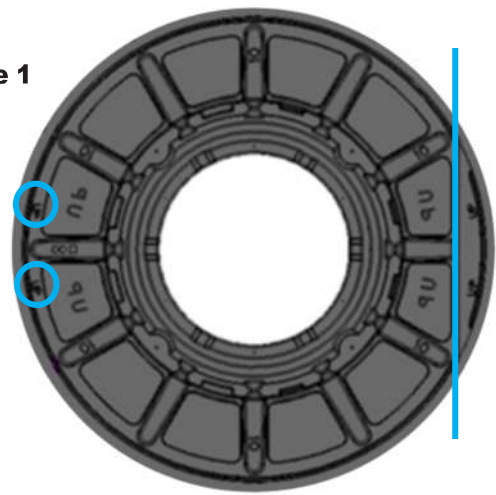


Figure 2

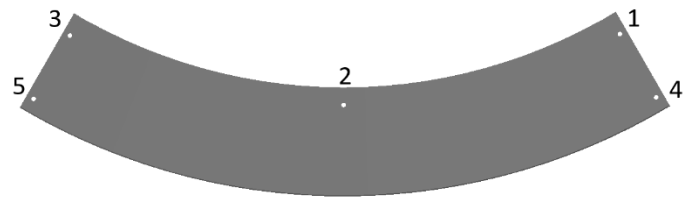
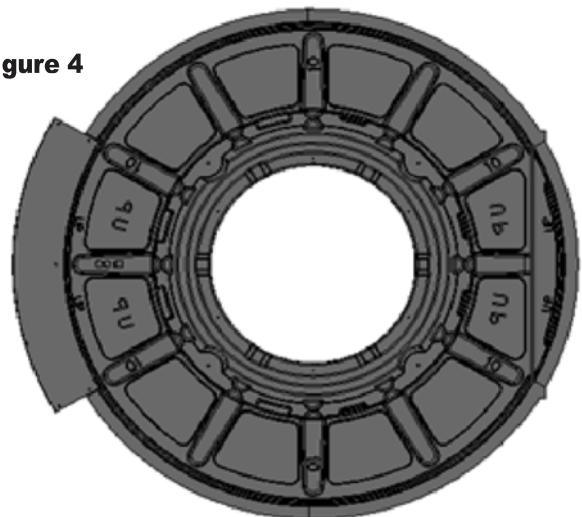


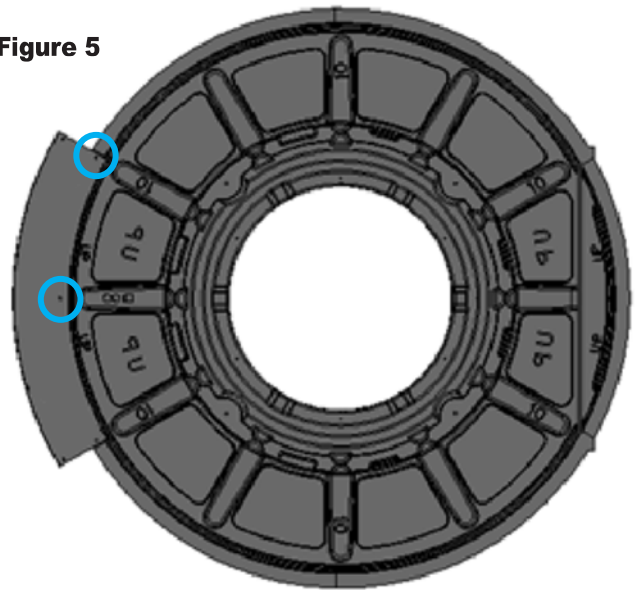
Figure 3



Figure 4

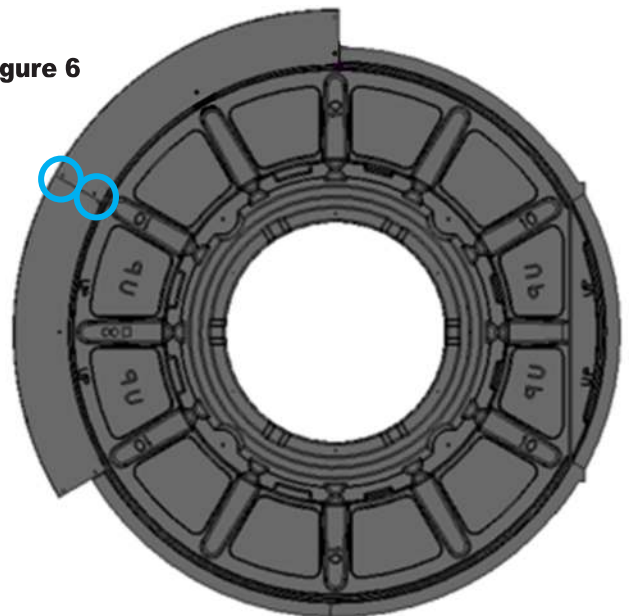


**Figure 5**



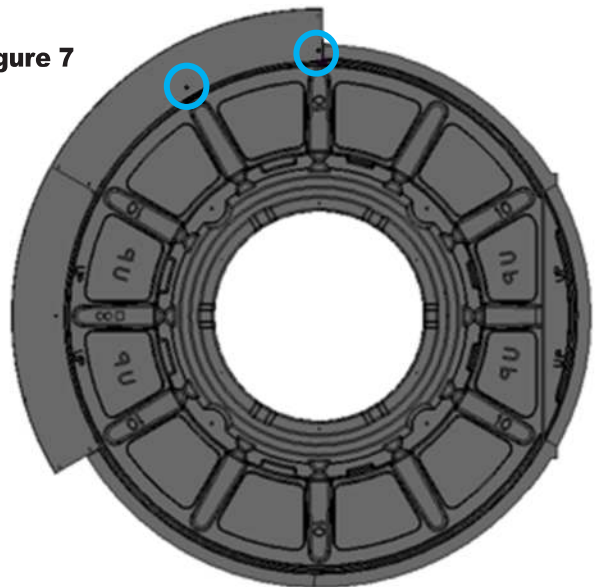
5. Drill the 2 hole locations as shown (Figure 5).
  1. Start with hole 2. Use a  $\frac{5}{16}$ " drill to drill hole through baffle, using plate as a guide.
  2. Bolt with  $\frac{1}{4}$ " x 1.5" bolt, washers, and nut.
  3. Flex plate to match the radius of the baffle.
  4. Drill hole at location 3. **Do not** bolt yet.

**Figure 6**



6. Add a second plate. The second plate will overlap **on top** of the first plate. Line up plates and bolt holes 5 (of plate 1) & 4 (of plate 2) together, as shown (Figure 6). Bolt holes 3 (of plate 1) & 1 (of plate 2) and the baffle together.

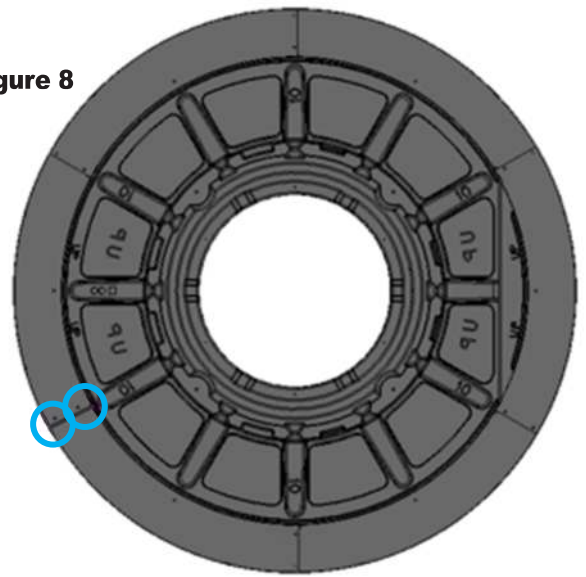
**Figure 7**



7. Drill holes 2 & 3 on the second plate. Bolt hole 2. (Figure 7)

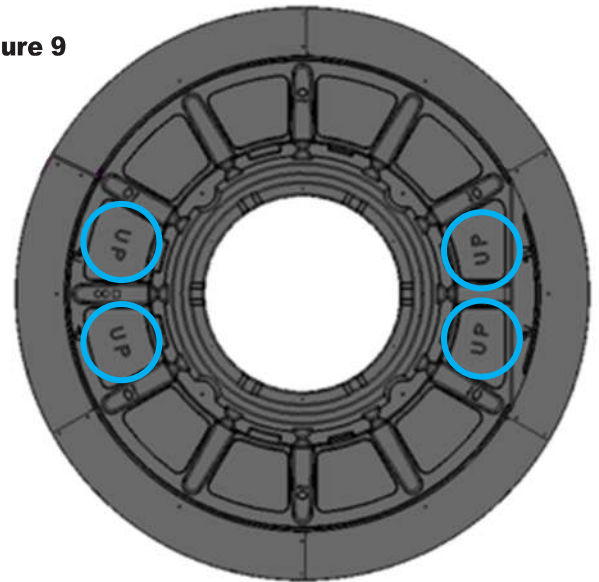
8. The third plate slides under the second plate. Continue the pattern all the way around the baffle. Bolt the plates and baffle together until it is one complete piece (Figure 8). When you get to bolting the last plate in place, align holes 3 and 5 of the last plate with holes 1 and 4 of the first plate. If the final alignment is not perfect, you may run the drill through the holes to finish installing these last two bolts.

**Figure 8**



9. This baffle is now done. It must be flipped over so that the large "UP" (Figure 9, circled) is now reading correctly. With a second person, grab, lift, and flip the baffle assembly.

**Figure 9**



10. The assembly of the Arcadia unit can begin as soon as the first baffle is complete. Skip to **SECTION 3 STEP 1** to begin assembly.

## 2B: Large Spoked Baffle (B)

1. Place a Large Spoked Baffle (B) on the ground with small "UP" (circled) letters reading correctly (Figure 10). Note the location of the weir slot (line). You will need to assemble 3 of these baffles.

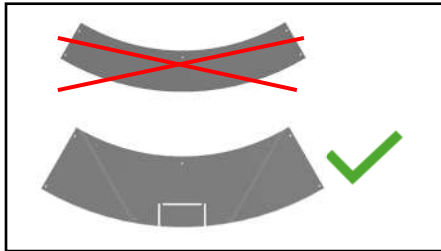
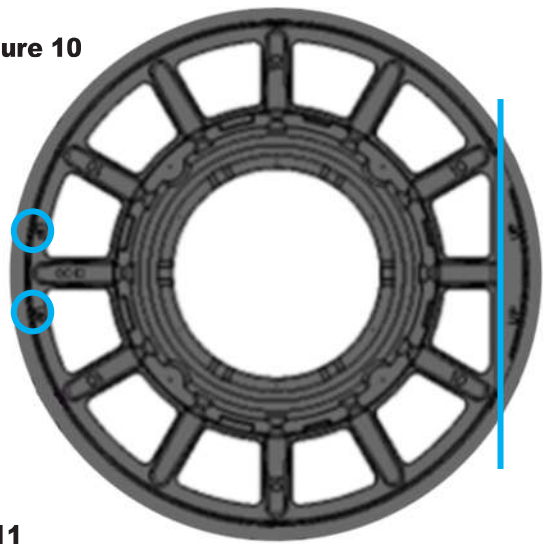
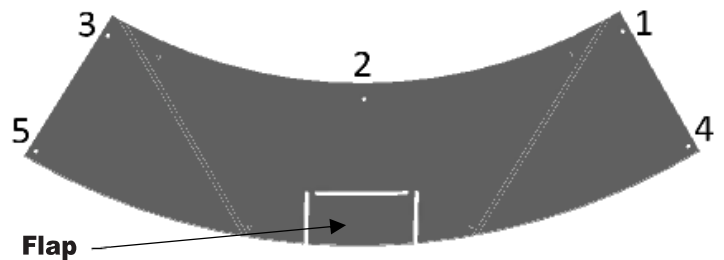


Figure 10



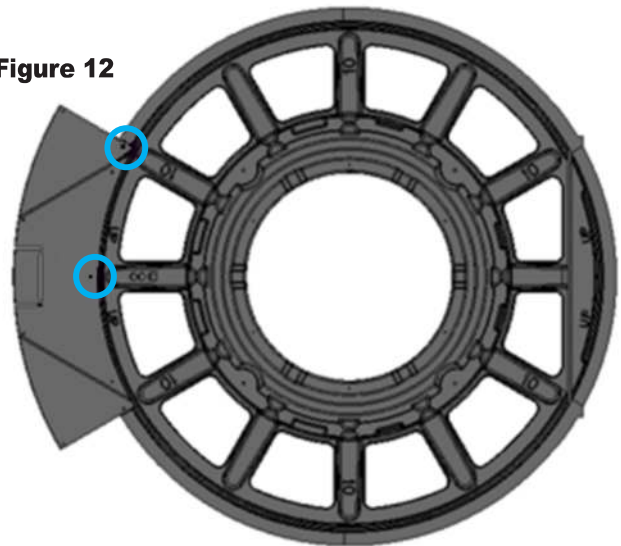
2. Get one of the large plates (Figure 11) (16" wide, with flap cutout). The hole numbers in Figure 11 will be referred to in the following

Figure 11



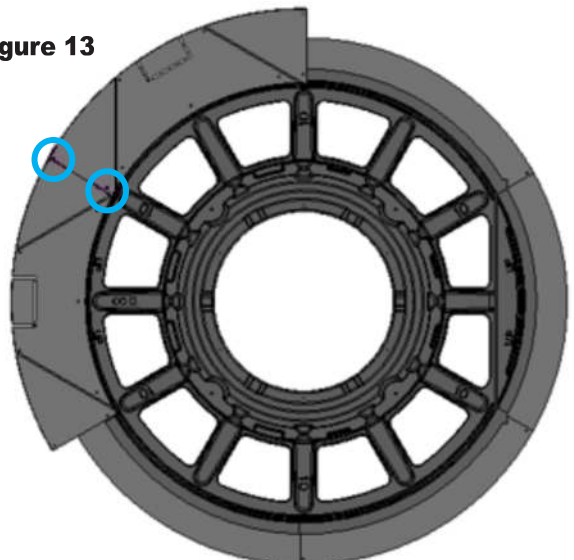
3. Starting opposite the weir slot, place the large plate in the recessed area. There is a registration mark, similar to the one shown in Figure 3, on the baffle to help you align the center. It is near the manufactured date wheels on the part. Hole 2 aligns with the registration mark. The entire plate should be centered in the recessed portion of the baffle. Push and bend plate to match the baffle edge.

Figure 12



4. Drill the 2 holes as shown (Figure 12).
  - a. Start with hole 2. Use  $\frac{5}{16}$ " drill to drill hole through baffle, using plate as a guide.
  - b. Bolt with  $\frac{1}{4}$ " x 1.5" bolt, washers, and nut.
  - c. Flex plate to match the radius of the baffle.
  - d. Drill hole at location 3. **Do not** bolt yet.

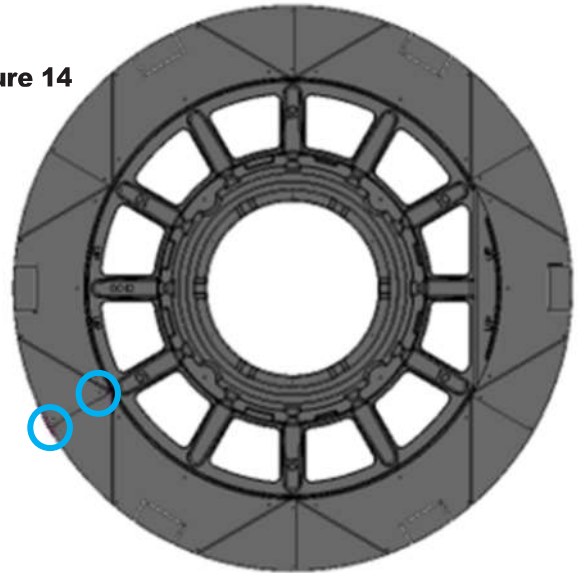
Figure 13



5. Add a second plate. The second plate will overlap **on top** of the first plate. Line up plates and bolt holes 5 (of plate 1) & 4 (of plate 2) together, as shown (Figure 13). Bolt holes 3 (of plate 1) & 1 (of plate 2) and the baffle together.

6. Drill hole 2 & 3 on the second plate. Bolt hole 2.
7. The third plate slides **under** the second plate. Continue the pattern all the way around the baffle. Bolt the Plates and Baffle together until it is one complete piece (Figure 14). When you get to bolting the last plate in place, align holes 3 and 5 of the last plate with holes 1 and 4 of the first plate. If the final alignment is not perfect, you may run the drill through the holes to finish installing these last two bolts.

**Figure 14**

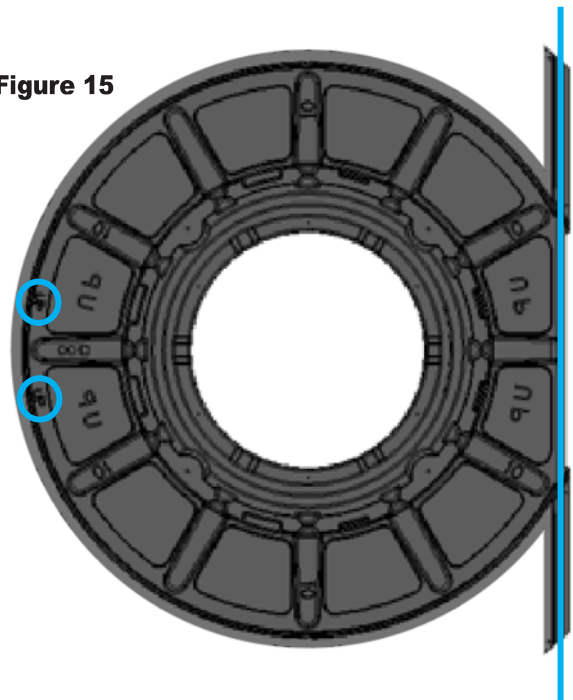


8. This baffle is now done. It does NOT need to be flipped over; it is already facing up. The assembly of the Arcadia unit can continue as each baffle is completed. Skip to SECTION2 STEP 5 to continue assembly.

## 2C: Top Baffle (C)

1. Place Top Baffle (C) on ground with small “UP” (circled) letters reading correctly (Figure15). Note the location of the weir slot (line). You will need to assemble 1 of these baffles.

**Figure 15**



2. Get one of the large plates (Figure 16) (16” wide, flap cutout). The hole numbers in Figure 16 will be referred to in the following steps.

**Figure 16**

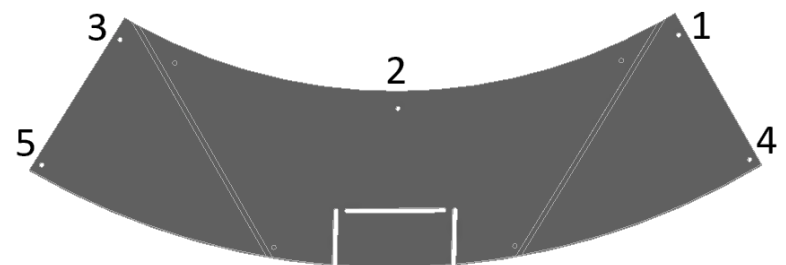
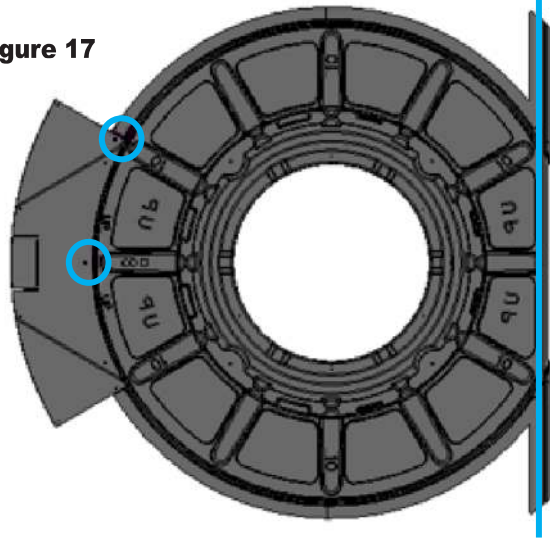


Figure 17

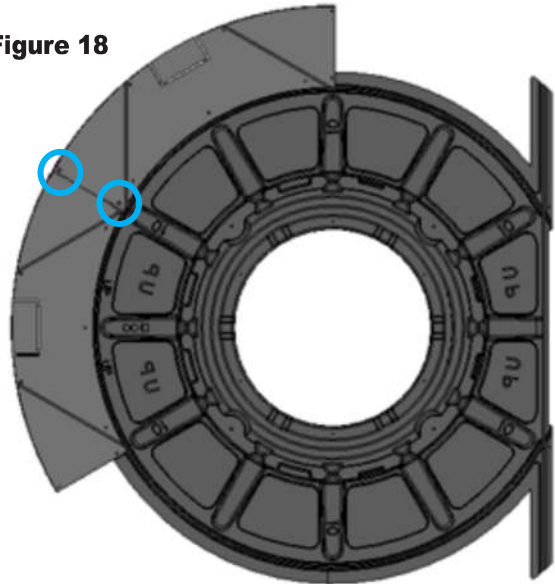


3. Starting opposite the weir slot, place the large plate in the recessed area. There is a registration mark, similar to the one shown in Figure 3, on the baffle to help you align the center. It is near the manufactured date wheels on the part. Hole 2 aligns with the registration mark. The entire plate should be roughly centered in the recessed portion of the baffle. Push and bend plate to match the baffle edge.

4. Drill the 2 holes as shown (Figure 17).

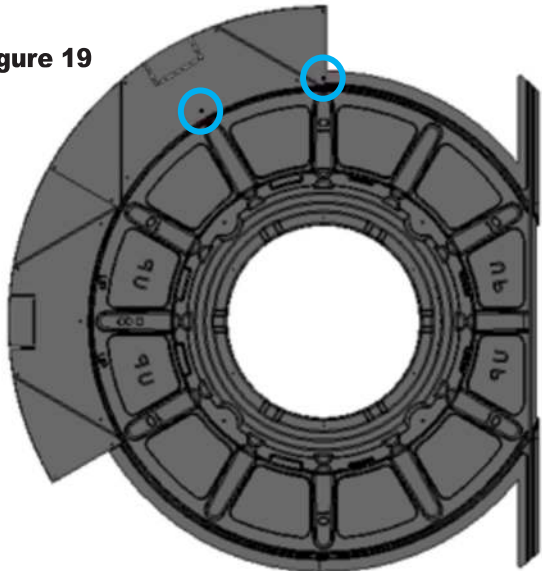
- a. Start with hole 2. Use  $\frac{5}{16}$ " drill to drill hole through baffle, using plate as a guide.
- b. Bolt with  $\frac{1}{4}$ " x 1.5" bolt, washers, and nut.
- c. Flex plate to match the radius of the baffle.
- d. Drill hole at location 3. **Do not** bolt yet.

Figure 18



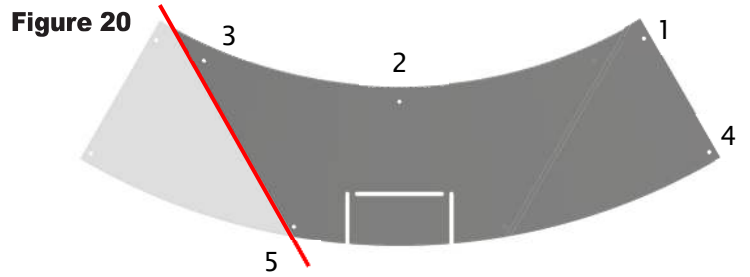
5. Add a second plate. The second plate will overlap **on top** of the first plate. Line up plates and bolt holes 5 (of plate 1) & 4 (of plate 2) together as shown (Figure 18). Bolt holes 3 (of plate 1) & 1 (of plate 2) and the baffle together.

Figure 19



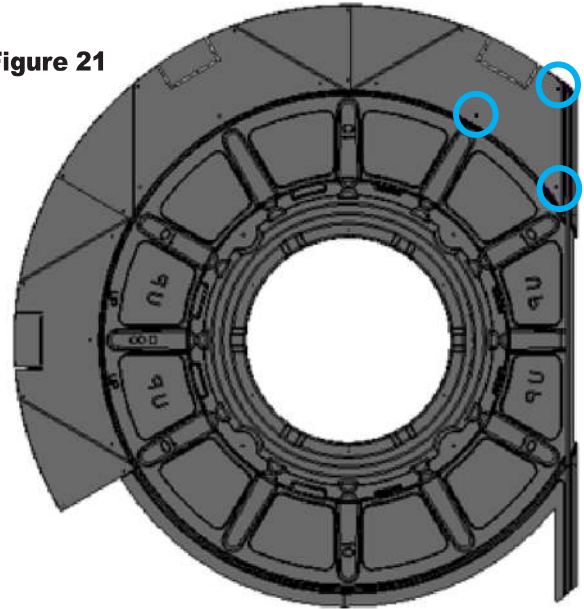
6. Drill hole 2 & 3 on the second plate. Bolt hole 2. (Figure 19)

- Cut a large plate on the pre-marked line as shown (Figure 20). Use the hole number guide in Figure 20 for this part. Note: Holes 3 and 5 are in a different location compared to the uncut plate.



- The third plate slides under the second plate. Line up plates and bolt holes 5 (of plate 2) & 4 (of plate 3) together as shown (Figure 21). Bolt holes 3 (of plate 2) & 1 (of plate 3) and the baffle together.

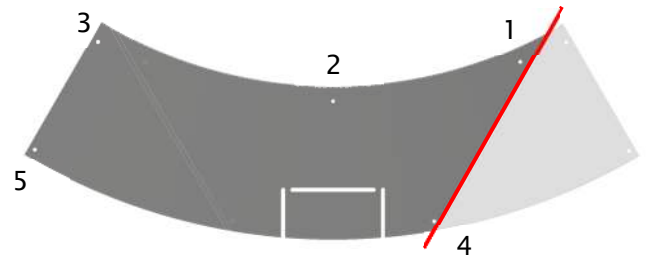
Figure 21



- Push this third plate into position. Drill and bolt holes 2, 3 & 5 to the baffle (Figure 21). Bolt positions 3 & 5 are pre-marked, but not pre-drilled.

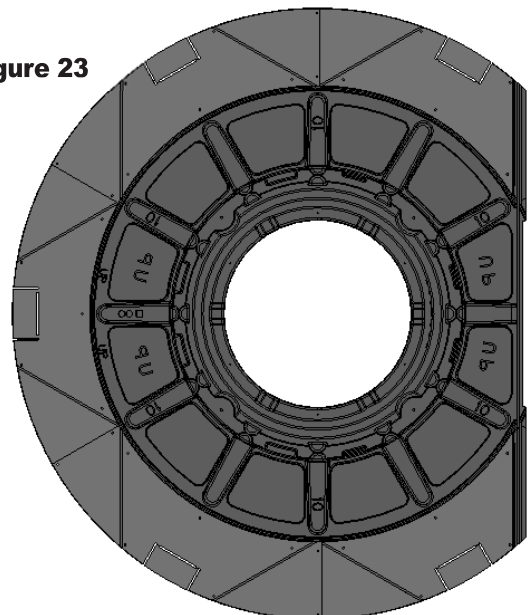
- Cut a large plate on the pre-marked line as shown (Figure 22). Use this hole number guide for this part. Note: Holes 1 and 4 are in a different location compared to the uncut plate.

Figure 22



- Add the last 2 plates in the same manner as steps 5,6, and 8. The final assembly will appear as shown (Figure 23).

Figure 23



- The Top Baffle (C) is now complete. It does **NOT** need to be flipped over; it is already facing up. The assembly of the Arcadia unit can continue as each baffle is completed.

## Section 3: Assembling Internal Components

### 3A: Rigging and Safety Methods:

1. Small Baffle (A)
  - a. Use minimum 14' long straps passed through the center hole and around the baffle edges. (Figure 24)
  - b. Alternately pass lifting straps between plates and baffle, leaving two bolts between pass-through locations. (Figure 25, 26)
  - c. Guy ropes or more straps may be needed to keep baffle horizontal while lifting.
2. Possible rigging method for Large Spoked Baffle (B) (Figure 27): Rig with lifting straps at least 14' long, looped through the baffle as shown. Guy ropes or more straps may be needed to keep baffle horizontal while lifting.
3. Rigging for TOP BAFFLE (C) is similar to the small baffles.
4. Arcadia All-Thread Alignment Tool (Figure 28). Use this to safely reach and adjust all-thread into the baffle holes as a baffle is lowered into place (see Figure 29). Do not work under suspended loads.

Figure 29

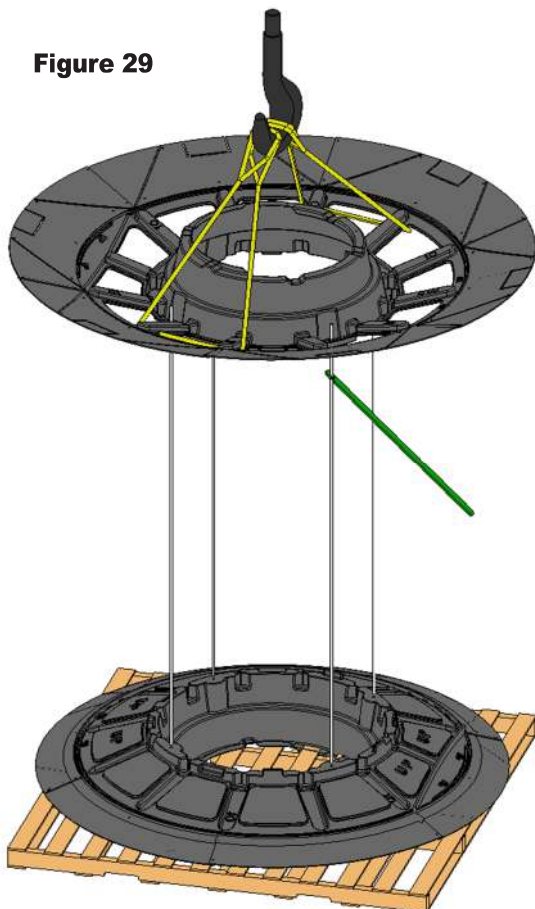


Figure 24

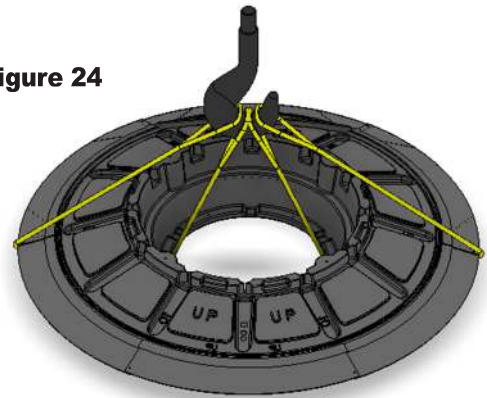


Figure 25



Figure 26



Figure 27

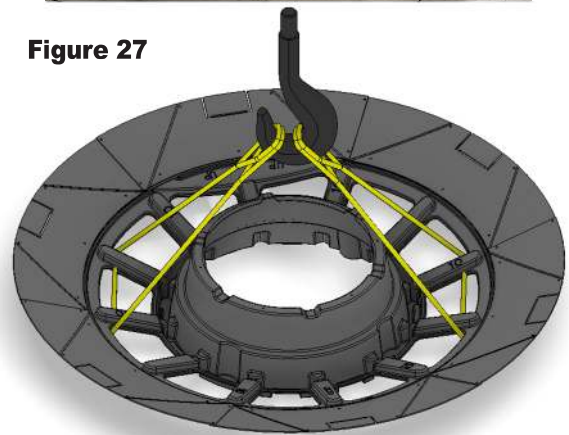
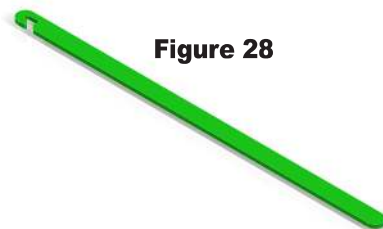


Figure 28



## Section 3B: Assembling Internals

*Note: Throughout this procedure, as you stack up the baffles, make sure to align the molded word UP for each layer. For each baffle, UP should be readable and aligned with previous layers shown in **Figure 30**.*

1. Suggested procedure to facilitate assembly:
  - Utilize shipping pallet to support the initial assembly.
  - This step utilizes the Cylinder (E) as a template. Place Cylinder (E) on pallet with flanged side down. Align the 4 holes so they each fall on the wood pallet surface. (see Figure 31).
  - Drill four 1/2" holes into the pallet. Set Cylinder aside for later steps.

*Note: Before beginning the next step, note that the correct orientation of the Small Baffle is indicated in Section 2A Step 9 (large "UP" reading correctly).*

### Figure 9

2. Rotate the first SMALL BAFFLE (A) onto its side and insert the 4 long threaded rods through the holes in the Baffle from the bottom side. The welded washer ends should be down when the baffle is rotated back to its upright orientation.
3. Place this SMALL BAFFLE (A) on the pallet with the molded word "UP" readable and facing upward.
4. Move the threaded rods so the bottom stub drops into the holes in the pallet that were drilled in step 1. This helps keep the threaded rods standing vertically.
5. Rotate one Large Spoked Baffle (B) as needed to ensure the word "UP" is aligned with the Small Baffle (A) as shown in Figure 30. Slide the Large Spoked Baffle (B) down the threaded rods until it rests on the Small Baffle (A) as shown in Figure 33. Each part mates with the previous part in only one orientation.
6. Rotate one Small Baffle (A) as needed to ensure the word "UP" is aligned with the Large Spoked Baffle (B) as shown in Figure 30. Slide the Small Baffle (A) down the threaded rods until it rests on the Large Spoked Baffle (B) as shown in Figure 33.
7. Repeat steps 5, then 6, then 5 again such that one more Small Baffle (A) and two more Large Spoked Baffles (B) have been added. The assembly should now have 6 total Baffles installed as shown in Figure 33.

**Figure 30**



**Figure 31**



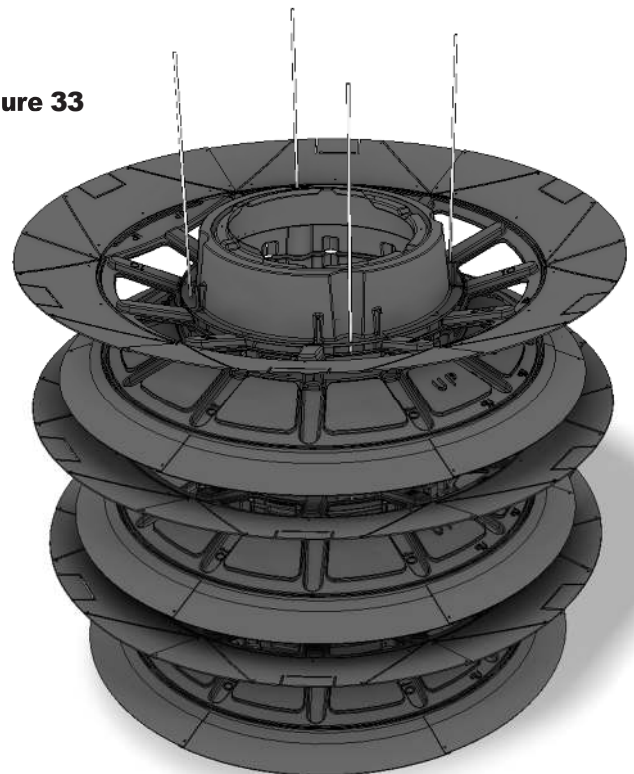
**Figure 32**



*Note: Throughout this procedure, as you stack up the baffles, use the All-Thread Alignment Tool to reach in and align the rod to pass through the baffle holes.*

**Figure 27.**

**Figure 33**



8. Slide SPACER (D) down the long threaded rods until it rests on the stack of 6 Baffles. The SPACER (D) flange should be oriented down, as shown in Figure 34.
9. Slide TOP BAFFLE (C) down the long threaded rods until it rests on the previous part, as shown in Figure 35. Each part mates with the previous part in only one orientation. Check that the molded word UP, on the outer edge is readable, facing upward, and aligned with the word UP on the previous part before sliding down the rods into position.
10. Grasping each long threaded rod between baffles, push each rod up until the washer is once again snug at the bottom of the stack, as shown in Figure 36. Hand snug a washer and nut to each long threaded rod with a wrench.

*Note: Recommended to hold the nut with the wrench and turn the threaded rod to snug.*

11. Add a nut and washer to each threaded rod. Top of washer shall be 12.75" above plastic baffle surface (Figure 37).
12. Two people are needed for this step. Assemble FRAME (G) by bolting the 4 metal pieces with provided short bolts, nuts, & washers, as shown in Figures 38 and 39.

*Note: Make sure the frame is installed upright, with the angled bends pointing upward, as shown in Figure 39.*

13. Slide FRAME (G) onto the threaded rods until it rests flat on nuts and washers added in Step 11. Orient FRAME (G) so that it aligns parallel to the flat portion of TOP BAFFLE (C), as shown in Figure 40.
14. Add another washer and nut to each of the long threaded rods above FRAME (G). Tighten. Then, attach a threaded coupling at the top end of each long threaded rod. Screw it down until the top of the coupling is flush with the top of the threaded rod. The hardware goes on as shown in Figure 41.

**Figure 34**



**Figure 35**



**Figure 36**



**Figure 37**



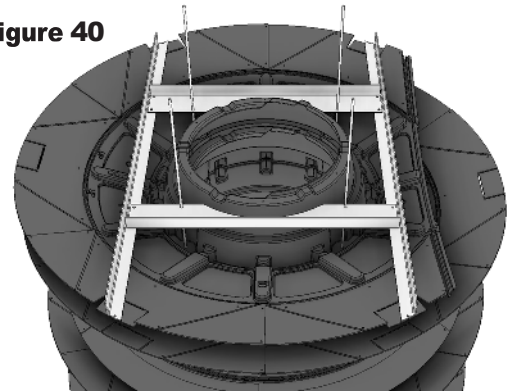
**Figure 38**



**Figure 39**



**Figure 40**



**Figure 41**



15. Place a washer and nut onto the end of the four short threaded rods, screwing about 3" (75 mm) down. Orient CYLINDER (E) with the flange facing up; feed the rods from the top through the holes in the CYLINDER (E) until the nuts rest on top of the CYLINDER, as shown in Figure 42.
16. Place CYLINDER (E) assembly on top of TOP BAFFLE (C). Each part mates with the previous part in only one orientation. Check that flat side of the flange of CYLINDER (E) is aligned with the flat side of the TOP BAFFLE (C) as shown in Figure 43. Attach the bottom end of the 4 short threaded rods to each threaded coupling at the top of the 4 long threaded rods. Hand tighten snug by twisting the long and short threaded rods in opposite directions.
17. Secure CYLINDER (E) onto each of the 4 short threaded rods with the washer and nut at the top. Hand snug with wrench.
18. Slide WEIR (F) into top slot with the curved edge down. Ensure WEIR (F) is centered in the slot. To easily insert WEIR (F), push one end home and secure lower corner of WEIR (F) to TOP BAFFLE (C) with a screw, as shown in Figures 44 and 45; then push the other end home and secure with screw. Add additional screws into the slot and through the bottom of the weir at approximately the middle, 1/4, and 3/4 positions.
19. Check and hand snug the nuts to the steel FRAME (G) with a wrench. Also hand snug the nuts to the top of the CYLINDER (E), and to the top of the TOP BAFFLE (C). Add a drop of Threadlocker to the rod threads near each nut before final tightening.
20. Secure the top of WEIR (F) with three screws into CYLINDER (E), as shown in Figure 46.
21. Attach Rod Caps to the top of each threaded rod, on top of the unit.
22. The finished assembly should appear as shown in Figure 47.

**Figure 42**



**Figure 43**



**Figure 44**



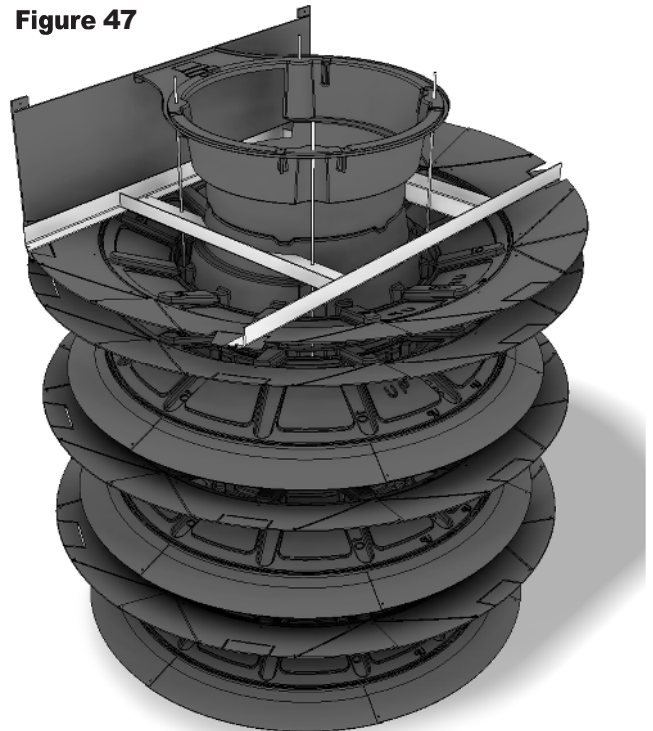
**Figure 45**



**Figure 46**



**Figure 47**



## Section 4: Mounting Brackets within Concrete Manhole Riser

Materials provided by ADS

- Brackets (Qty: 4)
- 3/8" (6.35 mm) Diameter 20 tpi, 3 1/4" (82.55 mm) wedge anchors (Qty: 4)

Other Tools Needed

- Drill
- 3/8" (6.35mm) Masonry drill bit
- Hammer
- 9/16" socket or wrench
- Masking Tape
- Rigging

1. Use one of the 2 methods below to locate and mark the elevation and center line for each of the 4 brackets.

a. Angular Dimensions Method:

From the outlet invert, measure depth A (Table 1) and around B° and C° in each direction to locate the top of each bracket. Mark top of bracket.

b. Linear Dimensions Method:

From the outlet invert, measure depth A (Table 2) and around the inside arc B" and C" in each direction to locate the top of each bracket. Mark top of bracket.

Crosscheck outlet invert elevations from approved job specific drawings.

Figure 48

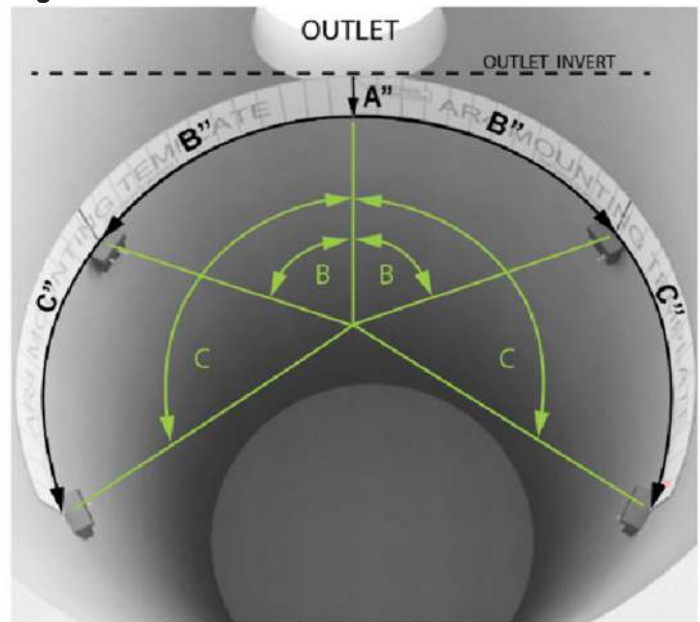


Table 1: Angular Measurements

Arcadia Model	A. Depth from Outlet Invert, in (mm)	B. Angle from Outlet Center, degrees	C. Angle from Outlet Center, degrees
AR10	9 (228.6)	60	120

Table 2: Linear Measurements

Arcadia Model	A. Depth from Outlet Invert, in (mm)	B. Measurement from Outlet Center, in (mm)	C. Measurement from Outlet Center, in (mm)
AR10	9 (228.6)	62 3/4 (1595.9)	125 5/8 (3191.9)

2. Hold bracket in position in manhole at locations indicated. Mark anchor holes for each bracket as shown in Figure 49.
3. Drill two 3/8" holes per bracket, 2½" (63.5 mm) deep. Diagonal holes are recommended. Extra holes provided if needed as shown in Figure 50.
4. Attach 4 brackets to manhole at positions marked, aligned with top of bracket. Lightly hammer the anchors in place. Tighten the locking nuts to firmly secure brackets to the concrete.

Trim any excess anchor that extends beyond the bracket edge as shown in Figure 51.

5. Extend center lines up the manhole wall to the top. Also extend lines across top edge. These center lines will be used by installers at the jobsite to align the unit during installation as shown in Figure 52.

*Note: These center lines are part of the bracket installation and should be made with a suitable marking device that can be easily seen, such as a level and marker, or chalk line.*

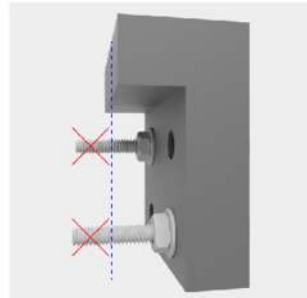
**Figure 49**



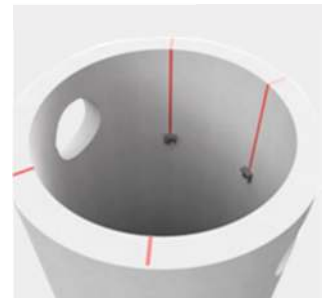
**Figure 50**



**Figure 51**



**Figure 52**



## Section 5: Transporting Assembled Arcadia Internals

Placing assembled Arcadia inside concrete manhole riser section for transportation.

1. Choosing a segment of precast concrete manhole riser or base.
  - For transport, choose a riser section that does not contain the mounting brackets, minimum riser depth shown in Table 3. This riser section will serve as shipping containment for the internals.
  - The Arcadia internals will be permanently installed onto the mounting brackets at the jobsite. See Section 6.

**Table 3: Angular Measurements**

Minimum Depth Transport Riser Section ft (m)	Arcadia Model
6 (1.8)	AR10

2. Rigging Arcadia Internals for lifting.
  - Use the stainless-steel frame arms as pick points for straps, chains, or other qualified rigging. It is recommended to attach at diagonally opposite arms.
  - Appropriate rigging examples are shown in Figures 53 and 54.
3. Place Arcadia Internals within the riser segment using hoisting equipment.
4. Secure with strapping.
5. Along with the internals, be sure to also deliver the 3 additional items listed in the note to the right and seen in Figures 55, 56, and 57.

**Figure 53**



**Figure 54**



**Figure 55**



**Figure 56**



**Figure 57**



*Note: Please deliver the following additional items to the jobsite along with the assembled Arcadia unit.*

- Small hardware package marked "Arcadia Installation, For Jobsite Contractor (NOT FOR PRECASTER)"
- Con Seal roll(s)
- Copy of this Installation Guide

**Table 4: Arcadia Separator Internals Weight Once Assembled**

Arcadia Model	AR10
lbs (kg)	1306 (592.3)

## Section 6: Installing Arcadia Internals into the Manhole – For Contractor/Jobsite

These directions assume the manhole base and riser have not been assembled, and that the top slab has not been set.

Note: Do not insert the inlet or outlet pipes until after the Arcadia internals have been installed. If pipes must be inserted in advance, the pipes should not protrude into the structure as they can interfere with installation of the Arcadia Internals.

### Materials provided by ADS

- Arcadia Internals (Qty: 1)
- 3/8" Diameter 20 tpi, 3 1/4" (82.55 mm) wedge anchors (Qty: 2)
- 1/4" (6.35 mm) Diameter 1 1/2" (38.1 mm) long hex head lag screws and washers (Qty: 4)
- 1/4" (6.35 mm) high speed drill bit for drilling into steel brackets
- Conseal Roll(s)

### Other Tools Needed

- Drill
- 3/8" Masonry Drill Bit
- 3/16" (4.76 mm) Multi-Purpose Drill Bit
- Hammer
- 3/8" socket or wrench
- Rigging

1. Before assembling the manhole base and riser(s), remove the assembled Arcadia unit from the precast segment that was used for protection during transport, if applicable. Rig the Arcadia internals for overhead lifting. Use the stainless-steel frame arms as pick points for straps, chains, or other qualified rigging. It is recommended to attach diagonally to opposite arms. See Figures 58 and 59. Set the Arcadia unit on level ground.
2. Locate the concrete riser section with Arcadia Mounting Brackets installed.
3. Begin installation of concrete manholes up to and including the section identified in Step 2.
4. For the section identified in Step 2, check for bracket centerline markings inside and on top edge of the manhole. If no markings are present, find and extend the centerlines of each bracket along the inside of the riser all the way to the riser top edge as shown. These centerlines will be used to align the unit during installation. See Figure 60.
5. Rig Arcadia internals for overhead lifting. Use the stainless-steel frame arms as pick points for straps, chains, or other qualified rigging. It is

Figure 58



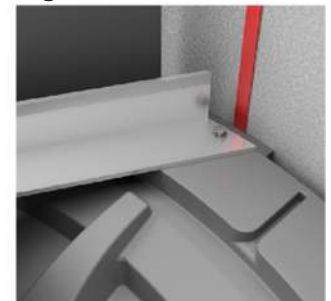
Figure 59



Figure 60



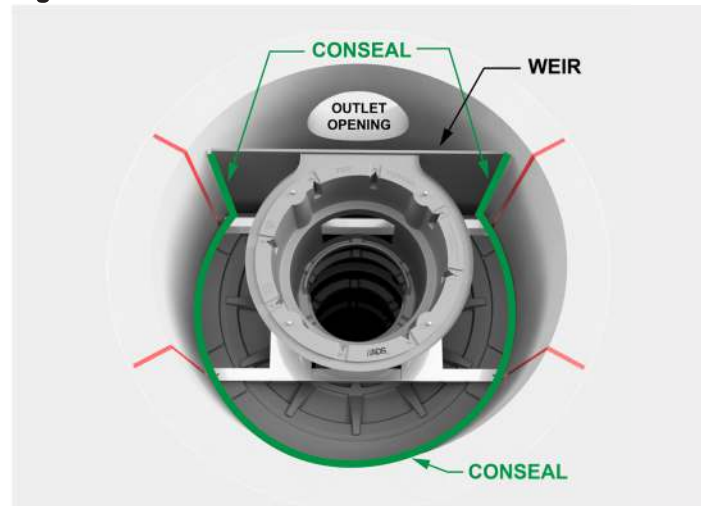
Figure 61



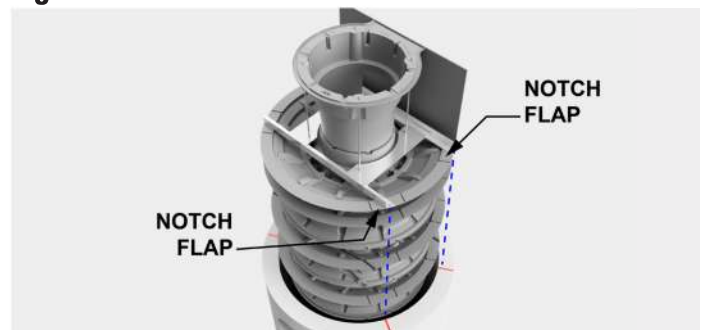
recommended to attach diagonally to opposite arms. See Figures 58 and 59.

6. Lift Arcadia internals at slow speed. Before lowering the unit into the manhole, check for proper alignment with the mounting brackets inside the manhole. Orientation is important throughout the entire installation process.
  - a. Keep the WEIR (F) centered above the outlet pipe opening. See Figure 62.
  - b. Keep frame arms aligned with bracket centerlines during the entire lowering process. Failure to maintain alignment could result in damage to the unit. See Figure 63.
7. Once aligned, slowly lower Arcadia internals into manhole. Utilize a spotter to guide the alignment of the unit with tagline. Proceed until the stainless- steel frame arms are resting on the pre-installed mounting brackets within the manhole.
8. Use the provided 1/4" (6.35 mm) drill bit to make a pilot hole in steel brackets. Affix Arcadia internals with provided lag screws and washers through the holes in the ends of the stainless-steel frame arms, through the top plastic of the unit and into the metal brackets beneath. Use 3/8" socket to drive in lag screws until snug (Figure 61).
9. Affix WEIR (F) edges to manhole walls using concrete anchors. See Figures 64 and 65.
10. Bend WEIR (F) installation tabs to the manhole wall as shown in Figure 64.
11. Mark holes for anchors, one hole per tab.
12. Drill a 3/8" hole 2 1/2" (63.5 mm) deep at each marked hole.
13. Bend WEIR (F) installation tabs to manhole wall.
14. Insert anchors and lightly hammer in place to secure WEIR (F) to manhole wall.
15. Tighten the locking nuts to firmly secure brackets to the manhole wall as shown in Figure 65.
16. Finally, seal WEIR (F) & TOP BAFFLE (C) edges to manhole wall using conseal to fill any gaps. See Figure 62.

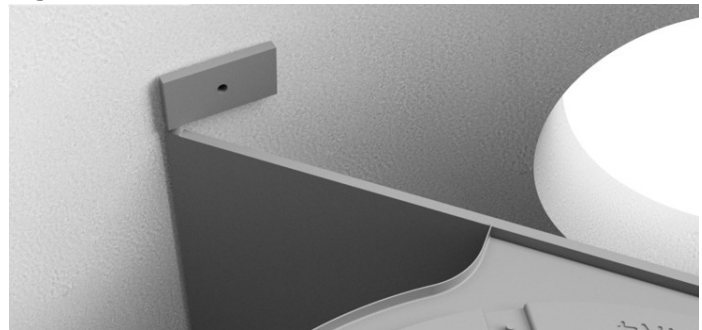
**Figure 62**



**Figure 63**



**Figure 64**



**Figure 65**

