

Structure ID: WQU5-6

P3 MH120RS96

MH RISER T/G

P6) 24" - CASTING HEIGHT - 7" P5) 120" - MH FLAT LID w/24in CON Hole F/G - 18" P4) 120" - MH RISER Custom Ht T/G - 44" P3) 120" - MH RISER T/G - 96" P2) 120" - MH RISER T/G - 96" P1) 120" - MH BASE T/n - 24" 1) ASSEMBLY REQUIRED - BRACKETS 1) CASTING - HOE MC-375 F/C Storm 4) 120" - Conseal CS-102 1.00" (Double) 2) Hole - 34	0 lb 16678 lb 16714 lb 34772 lb 36468 lb 25064 lb 0 lb 271 lb 0 lb 0 lb <hr style="width: 50%; margin-left: auto; margin-right: 0;"/> Structure Total: 129967 lb
---	--

Structure Notes:

1. PER ASTM C478 SPECIFICATIONS.
2. CONCRETE = 4,000 PSI AT 28 DAYS.
3. CASTING BY ICAST (HOE MC-375 F/C "STORM").
4. LIFTING ANCHORS TO BE INSTALLED ON THE OUTSIDE OF THE STRUCTURE.

REINFORCING PER ASTM A615 (GRADE 60).

- TOP SLAB (As .62) #5 BARS AT 6" C.C.E.W..
- RISER/WALLS (As .36)
- FLOOR (As .47) #5 BARS AT 8" C.C.E.W.

Rim: 606.51' Rim to Invert: 10.26' Slack: 0.12" Sump: 162" Step Position:

Position	Elev	Angle	Ext. (cw)	Pipe	Pipe OD	Connector	Hole	Horz Size	Up ()	Offset
Invert 1	596.25'	0°	0"	24" RCP B WALL	30"	Hole 34	34"	34.472"	33"	0"
Invert 2	596.25'	174°	215.618"	24" RCP B WALL	30"	Hole 34	34"	34.472"	33"	0"
Invert 3										
Invert 4										
Invert 5										
Invert 6										
Invert 7										
Invert 8										

RIGHT-SIDE UP VIEW (int. dimensions)

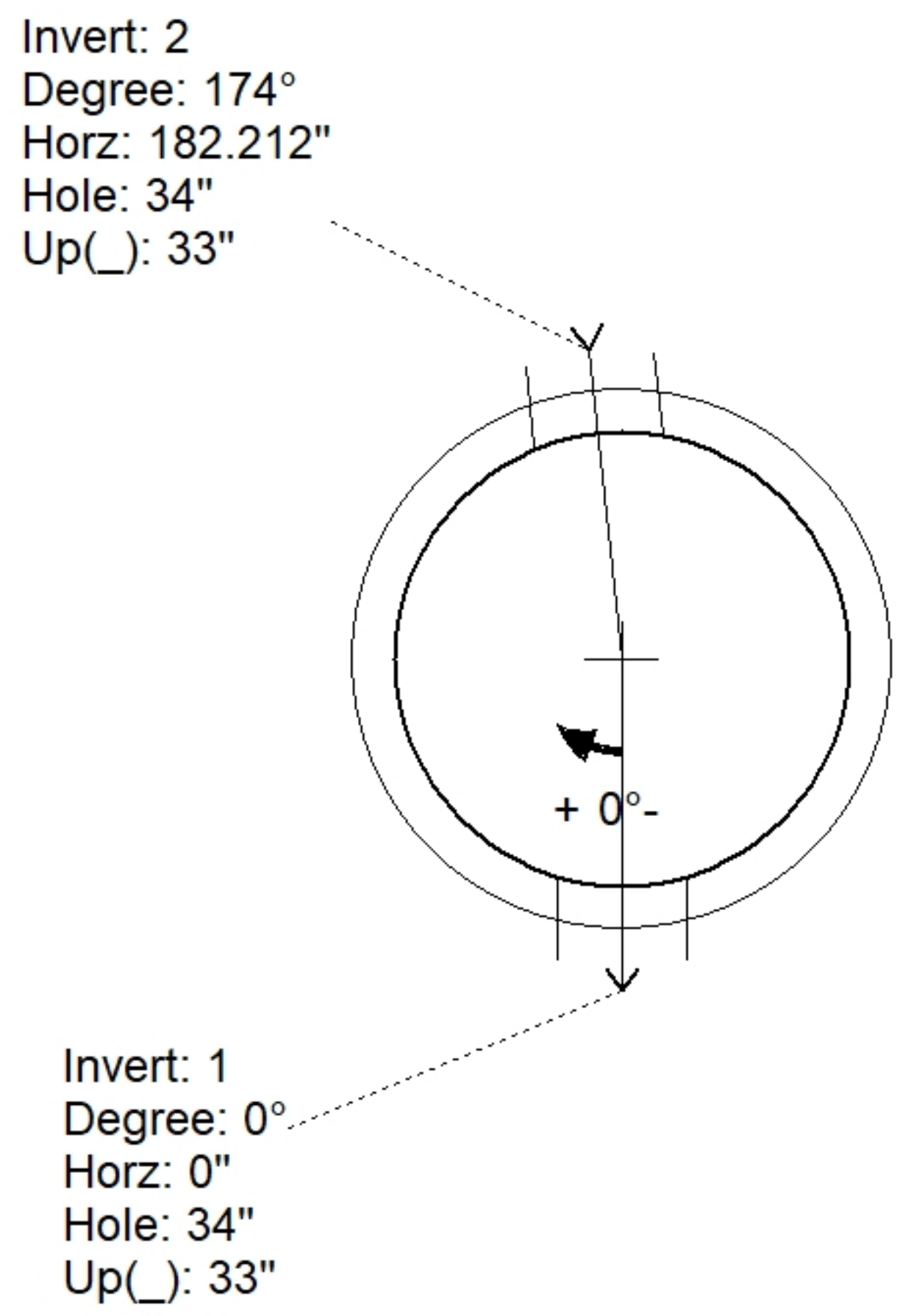
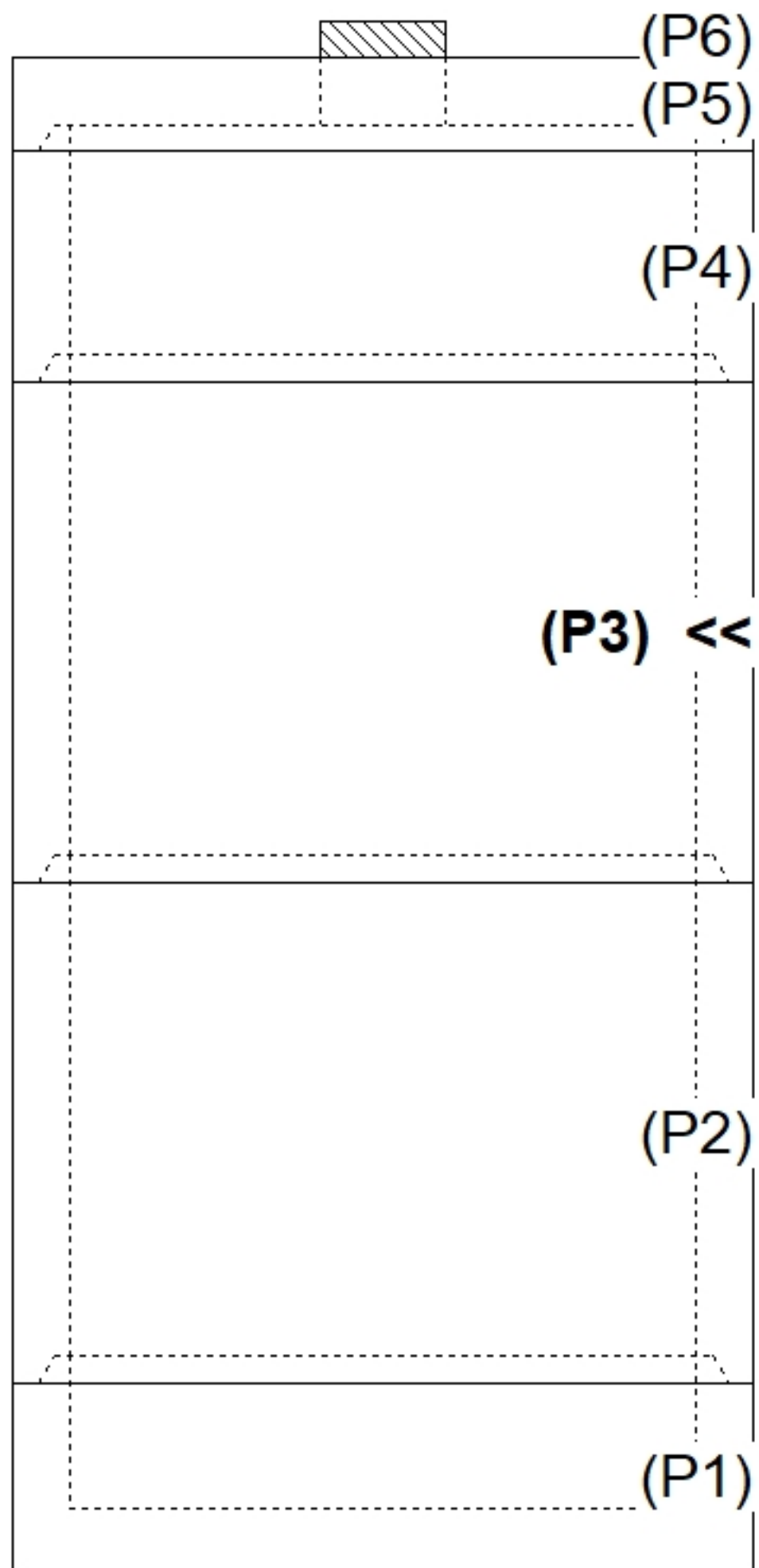

INSIDE WALL DIMENSIONS

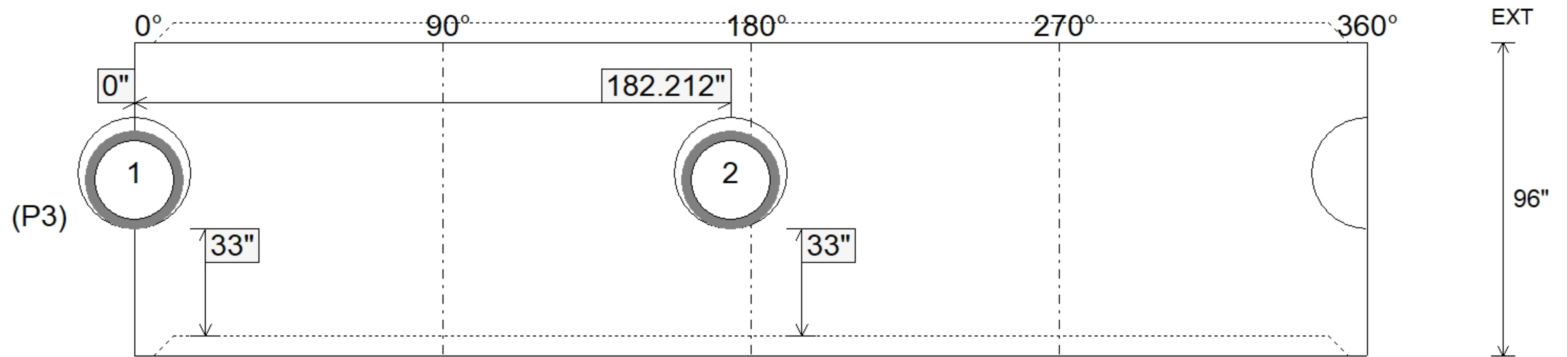

Coating (Int):	Seam Up: Tongue Seam Dn: Groove	Wall Thickness: 11" Floor Height: 0"	Height (Int): 96" Height (Ext): 96"
Coating (Ext):			Weight (Net): 34772 lb Volume (Net): 8.88cu.yd