

**Structure ID: WQU3-4**

**P2 MH048RS36**

**MH RISER T/G**

P5) 24" - CASTING HEIGHT - 7" P4) 48" - MH FLAT TOP w/ 24" Center Hole F/G - 12" P3) 48" - MH RISER T/G - 72" P2) 48" - MH RISER T/G - 36" P1) 48" - MH BASE T/n - 18" 1) ASSEMBLY REQUIRED 1) CASTING - HOE MC-375 F/C Storm 3) 48" - Conseal CS-102 1.00" (Double) 2) Hole - 26	0 lb 1580 lb 4563 lb 2515 lb 2588 lb 0 lb 271 lb 0 lb 0 lb ----- Structure Total: 11517 lb
---	--

**Structure Notes:**

1. PER ASTM C478 SPECIFICATIONS.
2. CONCRETE = 4,000 PSI AT 28 DAYS.
3. CASTING BY ICAST (HOE MC-375 F/C "STORM").
4. LIFTING ANCHORS TO BE INSTALLED ON THE OUTSIDE OF THE STRUCTURE.
5. P2 & P3 RISERS TO BE MECHANICALLY ATTACHED BEFORE INTERNAL INSTALLATION/DELIVERY.

REINFORCING PER ASTM A615 (GRADE 60).

- TOP SLAB (As .62) #5 BARS AT 6" C.C.E.W..
- RISER/WALLS (As .12)
- FLOOR (As .31) #5 BARS AT 12" C.C.E.W.

Rim: 617.87'    Rim to Invert: 5.85'    Slack: 6.2"    Sump: 81"    Step Position:

Position	Elev	Angle	Ext. (cw)	Pipe	Pipe OD	Connector	Hole	Horz Size	Up ( )	Offset
Invert 1										
Invert 2										
Invert 3										
Invert 4										
Invert 5										
Invert 6										
Invert 7										
Invert 8										

**RIGHT-SIDE UP VIEW (int. dimensions)**

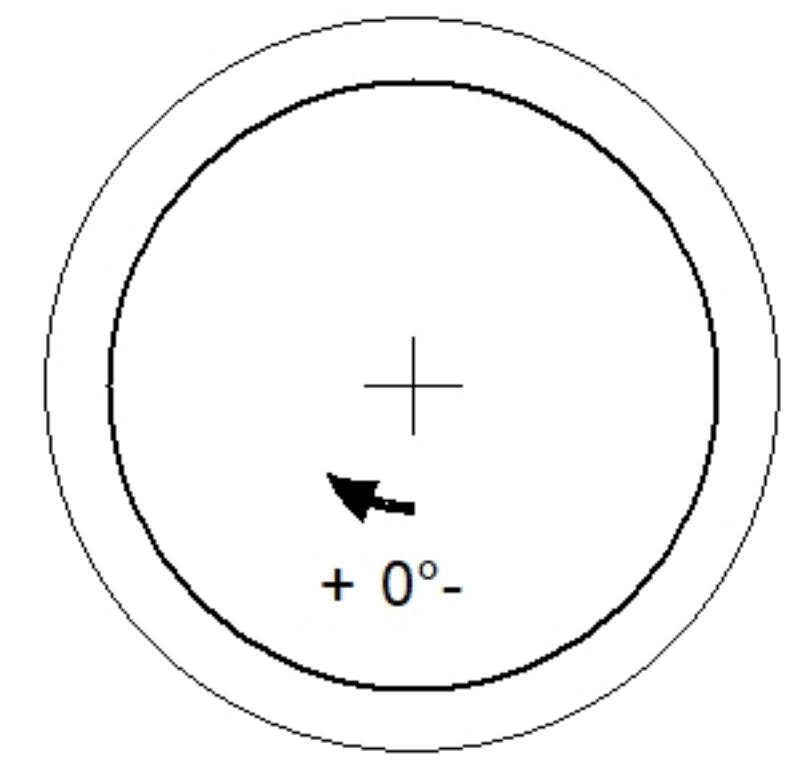
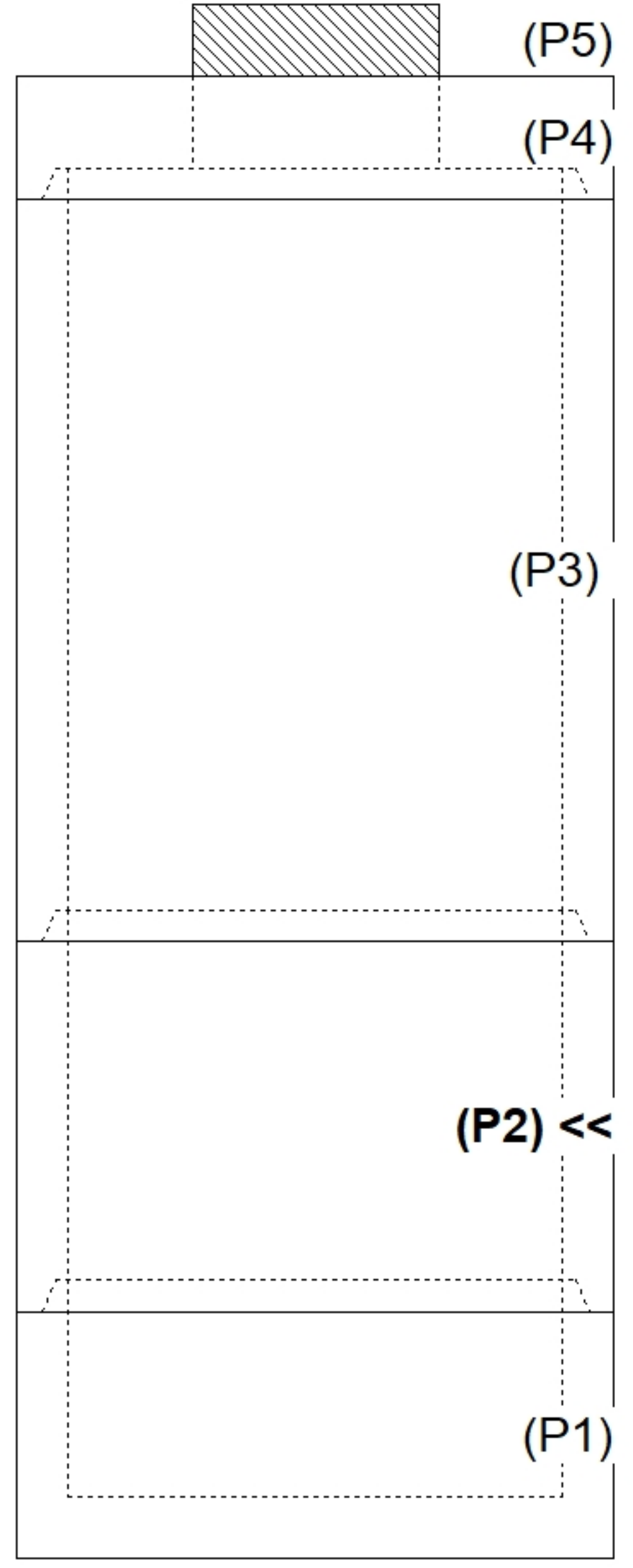

**INSIDE WALL DIMENSIONS**

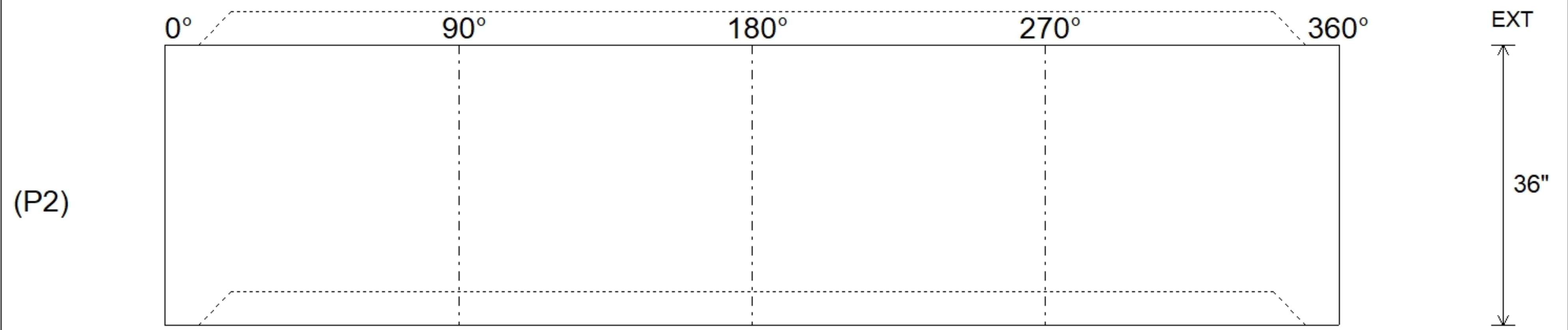

Coating (Int): Coating (Ext):	Seam Up: Tongue Seam Dn: Groove	Wall Thickness: 5" Floor Height: 0"	Height (Int): 36" Height (Ext): 36"	Weight (Net): 2515 lb Volume (Net): 0.64cu.yd
----------------------------------	------------------------------------	--	--	--