

Job Name: 26-1326 ADS 15 Meritage Homes
 Job Location: Antioch, TN
 Contractor: ADS Advanced Drainage Systems, Inc.

Plant: Beaver Dam
 2/19/2026 4:16:40 PM

Tech: S. Felletter
 PC: C. Goff



Structure ID: WQ6-7

P1 MH120BVF

MH BASE T/n

- P6) 24" - CASTING HEIGHT - 7"
- P5) 120" - MH FLAT LID w/24in CON Hole F/G - 18"
- P4) 120" - MH RISER Custom Ht T/G - 73"
- P3) 120" - MH RISER T/G - 96"
- P2) 120" - MH RISER T/G - 96"
- P1) 120" - MH BASE T/n - 24"
- 1) ASSEMBLY REQUIRED - BRACKETS
- 1) CASTING - HOE MC-375 F/C Storm
- 4) 120" - Conseal CS-102 1.00" (Double)
- 2) Hole - 48

0 lb
 16678 lb
 27731 lb
 33046 lb
 36468 lb
 25064 lb
 0 lb
 271 lb
 0 lb
 0 lb

 Structure Total: 139257 lb

Structure Notes:
 1. PER ASTM C478 SPECIFICATIONS.
 2. CONCRETE = 4,000 PSI AT 28 DAYS.
 3. CASTING BY ICAST (HOE MC-375 F/C "STORM").
 4. LIFTING ANCHORS TO BE INSTALLED ON THE OUTSIDE OF THE STRUCTURE.

REINFORCING PER ASTM A615 (GRADE 60).
 - TOP SLAB (As .62) #5 BARS AT 6" C.C.E.W..
 - RISER/WALLS (As .36)
 - FLOOR (As .47) #5 BARS AT 8" C.C.E.W.

Rim: 609.24' Rim to Invert: 13.01' Slack: 4.12" Sump: 162" Step Position:

FIRST POUR DRAWING

GENERAL NOTES:

1. MANUFACTURED TO ASTM C-478 (LATEST REVISION).
2. CONCRETE 5,000 PSI AT 28 DAYS.
3. REINFORCING: TOP AND BOTTOM MAT #5 BAR @ 8" C-C E.W. (GRADE 60).
4. WEIGHT: 25,064 LBS TOTAL.
 FIRST POUR: 9,117 LBS
 SECOND POUR: 15,947 LBS

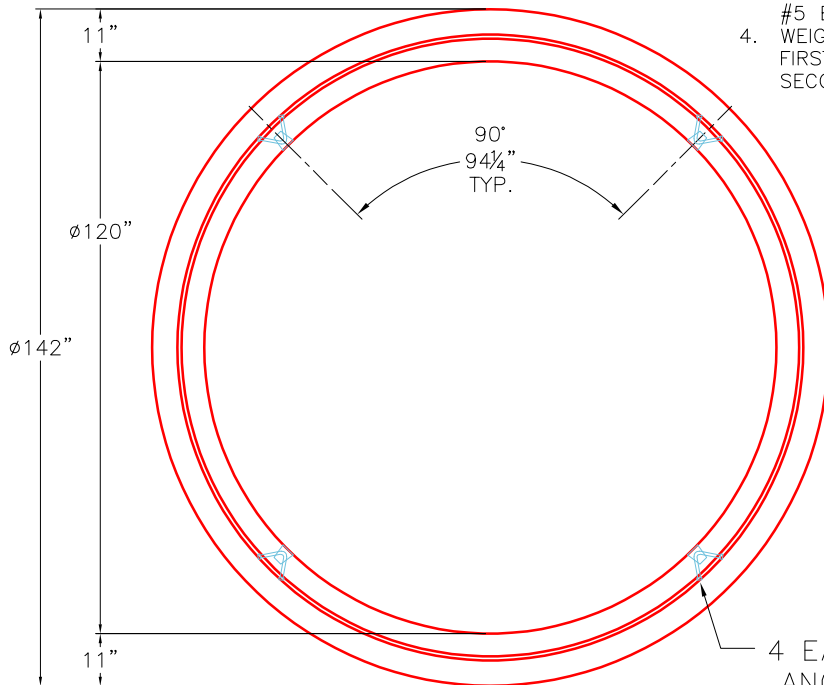

TOP VIEW

4 EA. CONAC 8CA18 ANCHORS REQUIRED FOR HANDLING.

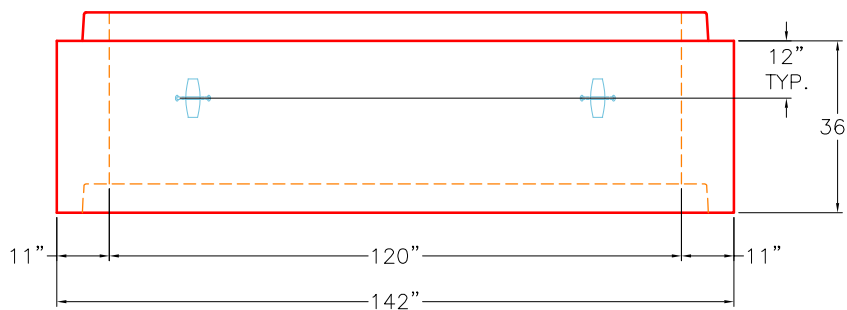

FRONT VIEW

Coating (Int):
 Coating (Ext):

Seam Up: Tongue
 Seam Dn: n/a

Wall Thickness: 11"
 Floor Height: 12"

Height (Int): 24"
 Height (Ext): 36"

Weight (Net): 25064 lb
 Volume (Net): 6.4cu.yd

Job Name: 26-1326 ADS 15 Meritage Homes
 Job Location: Antioch, TN
 Contractor: ADS Advanced Drainage Systems, Inc.

Plant: Beaver Dam
 2/19/2026 4:16:40 PM

Tech: S. Felletter
 PC: C. Goff



Structure ID: WQ6-7

P1 MH120BVF

MH BASE T/n

- P6) 24" - CASTING HEIGHT - 7"
- P5) 120" - MH FLAT LID w/24in CON Hole F/G - 18"
- P4) 120" - MH RISER Custom Ht T/G - 73"
- P3) 120" - MH RISER T/G - 96"
- P2) 120" - MH RISER T/G - 96"
- P1) 120" - MH BASE T/n - 24"
- 1) ASSEMBLY REQUIRED - BRACKETS
- 1) CASTING - HOE MC-375 F/C Storm
- 4) 120" - Conseal CS-102 1.00" (Double)
- 2) Hole - 48

0 lb
 16678 lb
 27731 lb
 33046 lb
 36468 lb
 25064 lb
 0 lb
 271 lb
 0 lb
 0 lb

 Structure Total: 139257 lb

- Structure Notes:**
1. PER ASTM C478 SPECIFICATIONS.
 2. CONCRETE = 4,000 PSI AT 28 DAYS.
 3. CASTING BY ICAST (HOE MC-375 F/C "STORM").
 4. LIFTING ANCHORS TO BE INSTALLED ON THE OUTSIDE OF THE STRUCTURE.

- REINFORCING PER ASTM A615 (GRADE 60).**
- TOP SLAB (As .62) #5 BARS AT 6" C.C.E.W..
 - RISER/WALLS (As .36)
 - FLOOR (As .47) #5 BARS AT 8" C.C.E.W.

Rim: 609.24' Rim to Invert: 13.01' Slack: 4.12" Sump: 162" Step Position:

SECOND POUR DRAWING

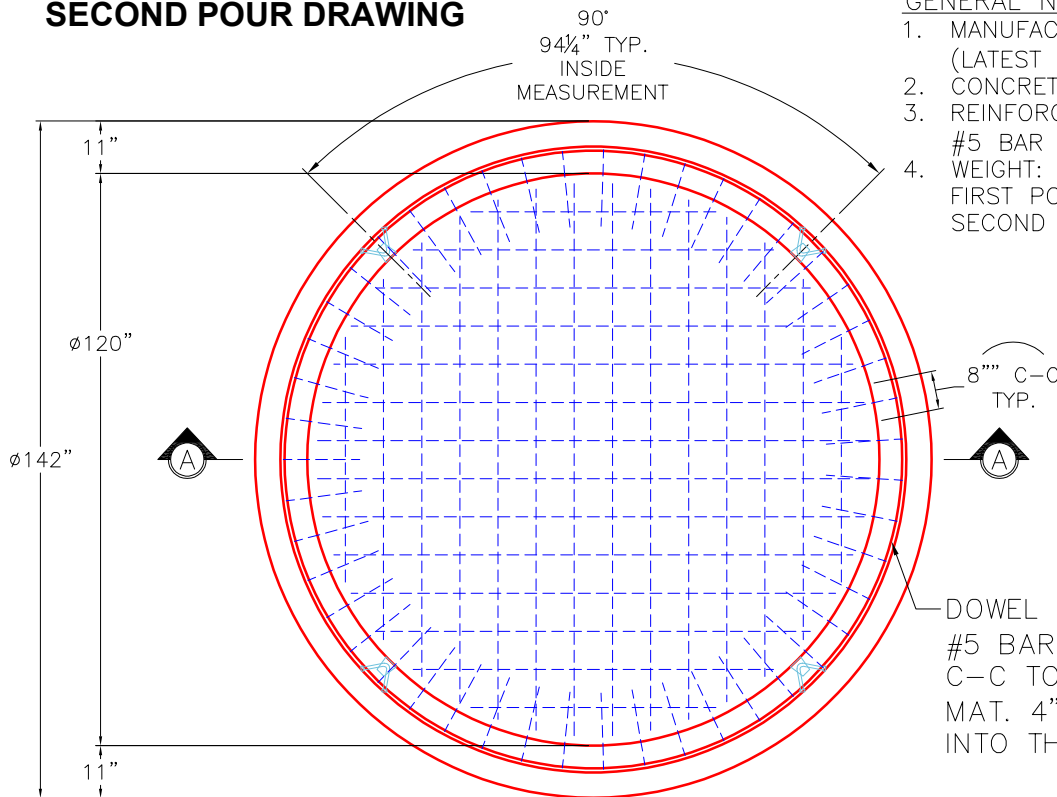

GENERAL NOTES:

1. MANUFACTURED TO ASTM C-478 (LATEST REVISION).
2. CONCRETE 5,000 PSI AT 28 DAYS.
3. REINFORCING: TOP AND BOTTOM MAT #5 BAR @ 8" C-C E.W. (GRADE 60).
4. WEIGHT: 25,064 LBS TOTAL.
 FIRST POUR: 9,117 LBS
 SECOND POUR: 15,947 LBS

DOWEL IN (94) 16" LONG #5 BAR (GRADE 60) 8" C-C TOP AND BOTTOM MAT. 4" MIN. PENETRATION INTO THE WALLS REQUIRED.

TOP VIEW

4 EA. CONAC 8CA18 ANCHORS REQUIRED FOR HANDLING.

#5 BAR @ 8" C/C E.W. TOP AND BOTTOM MAT

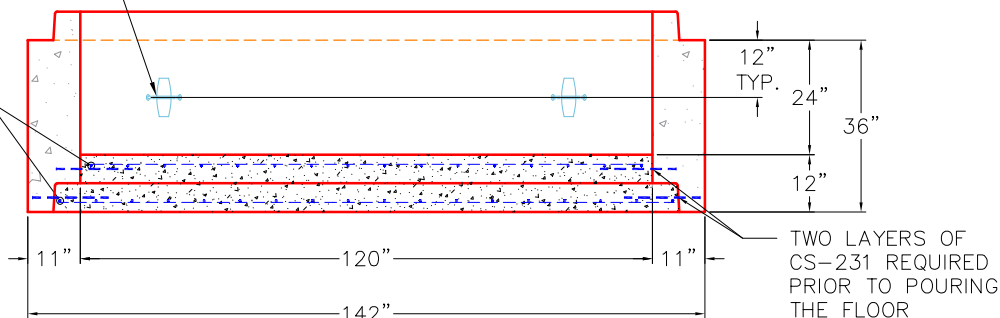

SECTION A-A

Coating (Int): Coating (Ext):	Seam Up: Tongue Seam Dn: n/a	Wall Thickness: 11" Floor Height: 12"	Height (Int): 24" Height (Ext): 36"
			Weight (Net): 25064 lb Volume (Net): 6.4cu.yd