

Job Name: 26-1322B - KYTC Warren Co Call 104 (261503)
 Job Location: Bowling Green, KY
 Contractor: Cumberland Pipeline LLC

Plant: 100

Tech: Jared - A

4/21/2026 3:37:21 PM

PC: Celina Goff



Structure ID: 257-78 SS-MH

P3 MH048CN24

ECC CONE w/ 24" HOLE F/G

- P4) 24" - CASTING HEIGHT - 7"
- P3) 48" - ECC CONE w/ 24" HOLE F/G - 24"
- P2) 48" - MH RISER T/G - 24"
- P1) 48" - MH BASE (08"F) T/n - 38"
- 1) 48" - MH INVERT CHANNEL - FULL HEIGHT
- 1) JOINT WRAP - 0.065"x6"x50' CONSEAL CS212
- 1) JOINT WRAP PRIMER - CONSEAL CS-75 (1 gal.)
- 1) CASTING - HOE MC-375 F/C BGMU Sanitary
- 2) 48" - Conseal CS-102 1.00" (Double)
- 2) PSX - 12-08 NYLO
- 6) MH Step ML-10-TDS-NCR - 10"

0 lb
 1550 lb
 1677 lb
 4332 lb
 1440 lb
 0 lb
 0 lb
 271 lb
 0 lb
 16 lb
 0 lb

 Structure Total: 9286 lb

Structure Notes:
 1. PER KYTC & ASTM C-478 SPECIFICATIONS
 2. CONCRETE: 4,000 PSI AT 28 DAYS
 3. REINFORCEMENT: PER ASTM A615
 4. STEPS REQUIRED
 5. HOE MC-375 FRAME & COVER "BGMU SANITARY" SUPPLIED BY ICAST

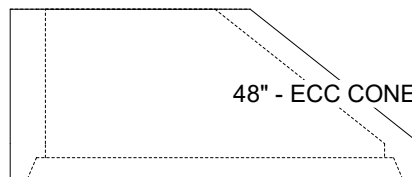
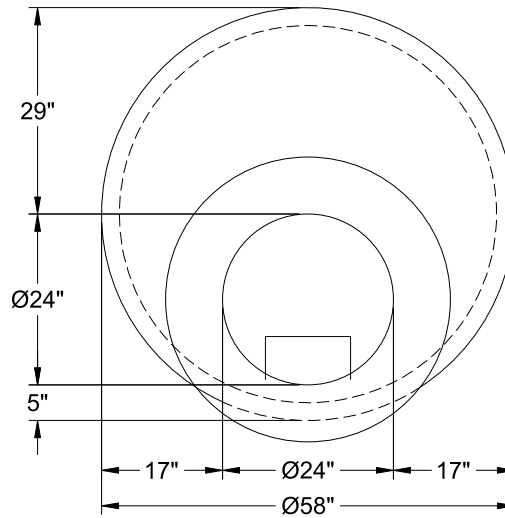

48" - ECC CONE w/ 24" HOLE F/G - 24" - (P3)

Coating (Int):
 Coating (Ext):

Seam Up: Flat
 Seam Dn: Groove

Wall Thickness: 5"

Height (Ext): 24"

Weight (Net): 1550 lb
 Volume (Net): 0.33cu.yd