

Job Name: 26-1322B - KYTC Warren Co Call 104 (261503)
 Job Location: Bowling Green, KY
 Contractor: Cumberland Pipeline LLC

Plant: 100

4/21/2026 2:25:08 PM

Tech: Jared - A

PC: Celina Goff

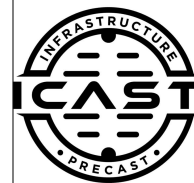

Structure ID: 230-72 SS-MH

P1 MH048BAVF

MH BASE (08"F) T/n

- P4) 24" - CASTING HEIGHT - 7"
- P3) 48" - ECC CONE w/ 24" HOLE F/G - 36"
- P2) 48" - MH RISER T/G - 24"
- P1) 48" - MH BASE (08"F) T/n - 28"
- 1) 48" - MH INVERT CHANNEL - FULL HEIGHT
- 1) JOINT WRAP - 0.065"x6"x50' CONSEAL CS212
- 1) JOINT WRAP PRIMER - CONSEAL CS-75 (1 gal.)
- 1) CASTING - HOE MC-375 F/C BGMU Sanitary
- 2) 48" - Conseal CS-102 1.00" (Double)
- 2) Kor-N-Seal1 - S106-20BW
- 6) MH Step ML-10-TDS-NCR - 10"

- 0 lb
- 3000 lb
- 1677 lb
- 3459 lb
- 1440 lb
- 0 lb
- 0 lb
- 271 lb
- 0 lb
- 13 lb
- 0 lb

Structure Total: 9860 lb

Structure Notes:

1. PER KYTC & ASTM C-478 SPECIFICATIONS
2. CONCRETE: 4,000 PSI AT 28 DAYS
3. REINFORCEMENT: PER ASTM A615
4. INVERT CHANNEL REQUIRED
5. STEPS AT 0 DEGREES
6. HOE MC-375 FRAME & COVER "BGMU SANITARY" SUPPLIED BY ICAST

Rim: 484.22' Rim to Invert: 7.82' Slack: 1.34" Sump: 2.5" Step Position: 0°

Position	Elev	Angle	Ext. (cw)	Pipe	Pipe OD	Connector	Hole	Horz Size	Up (↓)	Offset
Invert 1	476.4'	0°	0"	15" PVC SDR35	15.3"	Kor-N-Seal1 S106-20BW	20"	20.629"	0"	0"
Invert 2	476.5'	94°	47.625"	15" PVC SDR35	15.3"	Kor-N-Seal1 S106-20BW	20"	20.629"	1.25"	0"
Invert 3										
Invert 4										
Invert 5										
Invert 6										
Invert 7										
Invert 8										

RIGHT-SIDE UP VIEW (int. dimensions)

UPSIDE-DOWN VIEW (int. dimensions)

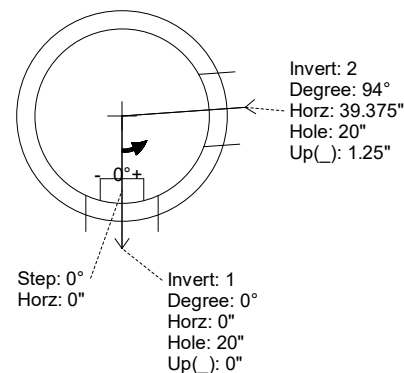
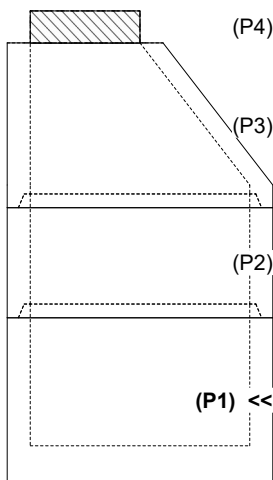

INSIDE WALL DIMENSIONS

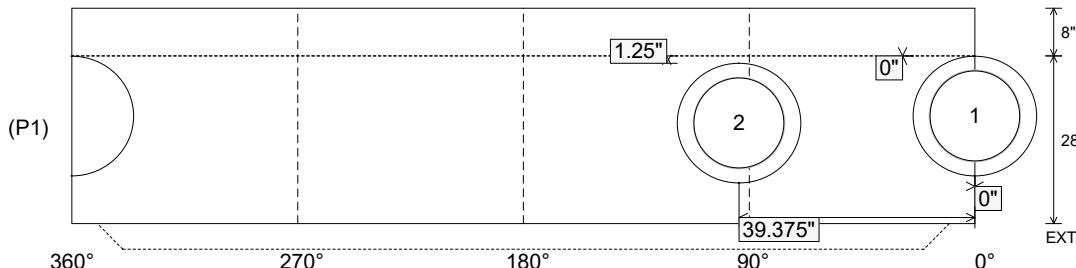

Coating (Int):
 Coating (Ext):

Seam Up: Tongue
 Seam Dn: n/a

Wall Thickness: 5"
 Floor Height: 8"

Height (Int): 28"
 Height (Ext): 36"

Weight (Net): 3459 lb
 Volume (Net): 0.88cu.yd

Structure ID: 230-72 SS-MH

P1 MH048BAVF

MH BASE (08"F) T/n

P4) 24" - CASTING HEIGHT - 7" P3) 48" - ECC CONE w/ 24" HOLE F/G - 36" P2) 48" - MH RISER T/G - 24" P1) 48" - MH BASE (08"F) T/n - 28" 1) 48" - MH INVERT CHANNEL - FULL HEIGHT 1) JOINT WRAP - 0.065"x6"x50' CONSEAL CS212 1) JOINT WRAP PRIMER - CONSEAL CS-75 (1 gal.) 1) CASTING - HOE MC-375 F/C BGMU Sanitary 2) 48" - Conseal CS-102 1.00" (Double) 2) Kor-N-Seal1 - S106-20BW 6) MH Step ML-10-TDS-NCR - 10"	0 lb 3000 lb 1677 lb 3459 lb 1440 lb 0 lb 0 lb 271 lb 0 lb 13 lb 0 lb Structure Total: 9860 lb
--	--

Structure Notes:

1. PER KYTC & ASTM C-478 SPECIFICATIONS
2. CONCRETE: 4,000 PSI AT 28 DAYS
3. REINFORCEMENT: PER ASTM A615
4. INVERT CHANNEL REQUIRED
5. STEPS AT 0 DEGREES
6. HOE MC-375 FRAME & COVER "BGMU SANITARY" SUPPLIED BY ICAST

Rim: 484.22' Rim to Invert: 7.82' Slack: 1.34" Sump: 2.5" Step Position: 0°

Position	Elev	Angle	Ext. (cw)	Pipe	Pipe OD	Connector	Hole	Horz Size	Up ()	Offset
Invert 1	476.4'	0°	0"	15" PVC SDR35	15.3"	Kor-N-Seal1 S106-20BW	20"	20.629"	0"	0"
Invert 2	476.5'	94°	47.625"	15" PVC SDR35	15.3"	Kor-N-Seal1 S106-20BW	20"	20.629"	1.25"	0"
Invert 3										
Invert 4										
Invert 5										
Invert 6										
Invert 7										
Invert 8										

RIGHT-SIDE UP VIEW (int. dimensions)

UPSIDE-DOWN VIEW (int. dimenions)

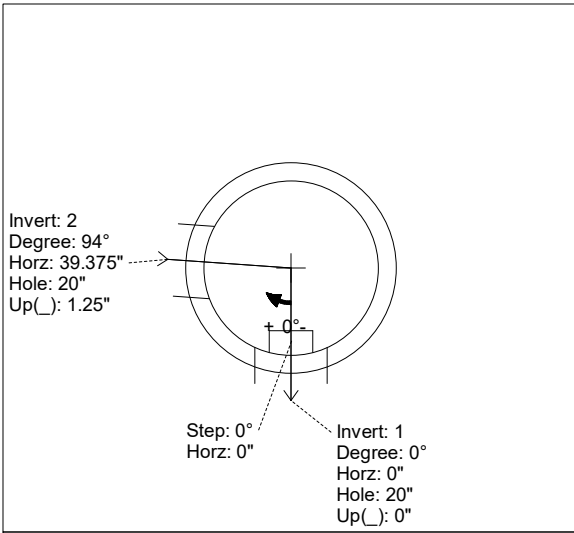
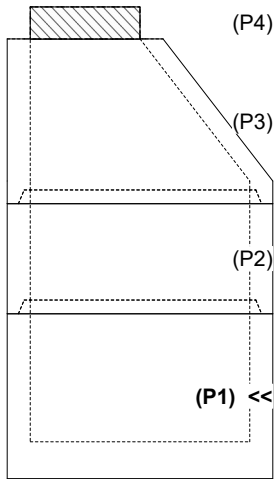

INVERT CHANNEL
DRAWING

INSIDE WALL DIMENSIONS

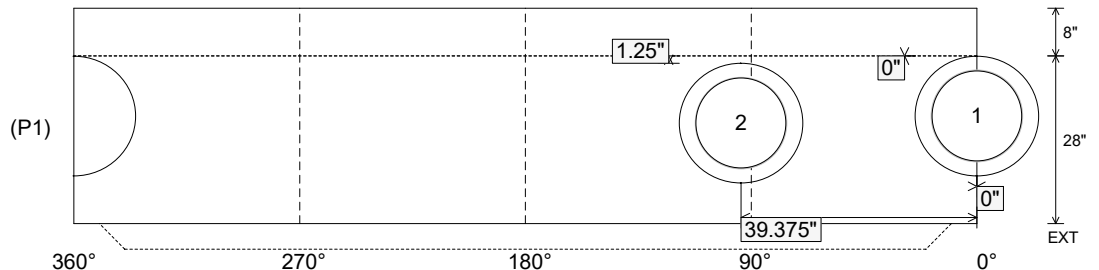

Coating (Int): Coating (Ext):	Seam Up: Tongue Seam Dn: n/a	Wall Thickness: 5" Floor Height: 8"	Height (Int): 28" Height (Ext): 36"	Weight (Net): 3459 lb Volume (Net): 0.88cu.yd
----------------------------------	---------------------------------	--	--	--