

**Job Name: 26-1322B - KYTC Warren Co Call 104 (261503)**  
**Job Location: Bowling Green, KY**  
**Contractor: Cumberland Pipeline LLC**

PC: Celina Goff  
 TECH: Jared - A  
 Plant: 100



Structure ID: 228-77 SS-MH

Spec: Sanitary  
 Type: SAN.MH  
 Size: 48"

Rim: 475.66'  
 Invert: 467.79'  
 Rim to Invert: 7.87'

Sump: 2.5"  
 Floor (Top): 467.582'  
 Floor Height: 8"

Floor (Bot): 466.915'  
 Overall Height: 8.583'  
 Slack: 1.94"

**Structure Notes:**

- PER KYTC & ASTM C-478 SPECIFICATIONS
- CONCRETE: 4,000 PSI AT 28 DAYS
- REINFORCEMENT: PER ASTM A615
- INVERT CHANNEL REQUIRED
- STEPS AT 0 DEGREES
- HOE MC-375 FRAME & COVER "BGMU SANITARY" SUPPLIED BY ICAST

**STRUCTURE SUMMARY:**

P4) 24" - CASTING HEIGHT - 7"	0 lb
P3) 48" - ECC CONE w/ 24" HOLE F/G - 24"	1550 lb
P2) 48" - MH RISER T/G - 24"	1677 lb
P1) 48" - MH BASE (08"F) T/n - 40"	4268 lb
1) 48" - MH INVERT CHANNEL - FULL HEIGHT	1440 lb
1) JOINT WRAP - 0.065"x6"x50' CONSEAL CS212	0 lb
1) JOINT WRAP PRIMER - CONSEAL CS-75 (1 gal.)	0 lb
1) CASTING - HOE MC-375 F/C BGMU Sanitary	271 lb
2) 48" - Conseal CS-102 1.00" (Double)	0 lb
1) Kor-N-Seal1 - S106-20BW	6 lb
1) Kor-N-Seal2 - S206-22L	6 lb
6) MH Step ML-10-TDS-NCR - 10"	0 lb
<b>Structure Total:</b>	<b>9219 lb</b>

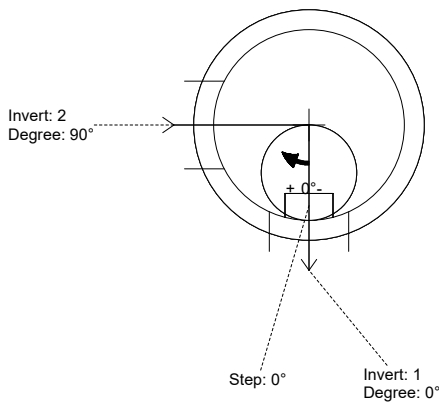

Position	Elev	Angle	Pipe	Pipe OD	Hole	Connector	Up (")	Ref
Rim	475.66'							
Reducer								
Invert 1	467.79'	0°	15" PVC SDR35	15.3"	20"	Kor-N-Seal1 S106-20BW	0"	P1
Invert 2	467.89'	90°	15" RCP B WALL	19.5"	22"	Kor-N-Seal2 S206-22L	0.25"	P1
Invert 3								
Invert 4								
Invert 5								
Invert 6								
Invert 7								
Invert 8								

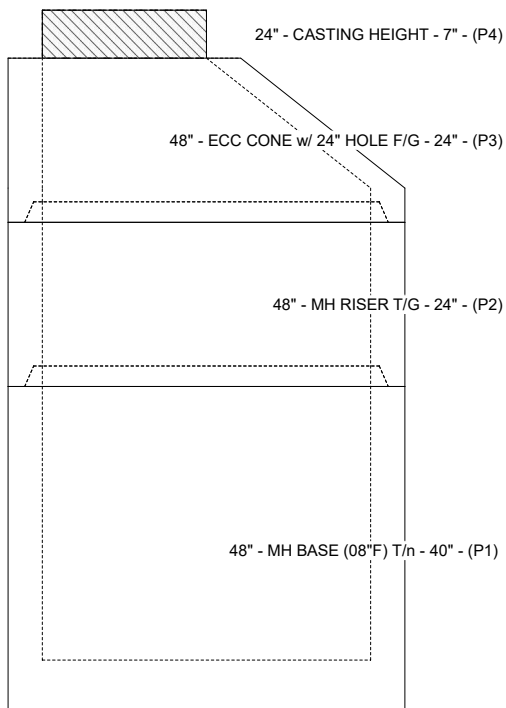

**Cast (Int. Dim.) - Interior Dimensions**

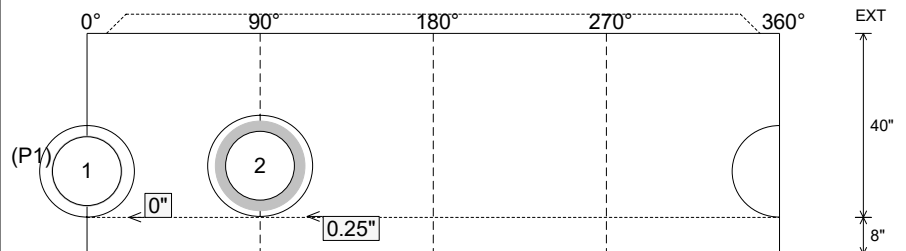

Submittal Drawing  
 4/21/2026 12:52:42 PM

SUBMITTAL  
 APPROVED BY: