

Job Name: 26-1322B - KYTC Warren Co Call 104 (261503)	Plant: 100	Tech: Jared - A	
Job Location: Bowling Green, KY Contractor: Cumberland Pipeline LLC	4/21/2026 2:25:10 PM	PC: Celina Goff	

Structure ID: 228-77 SS-MH

P1 MH048BAVF

MH BASE (08"F) T/n

P4) 24" - CASTING HEIGHT - 7"	0 lb
P3) 48" - ECC CONE w/ 24" HOLE F/G - 24"	1550 lb
P2) 48" - MH RISER T/G - 24"	1677 lb
P1) 48" - MH BASE (08"F) T/n - 40"	4268 lb
1) 48" - MH INVERT CHANNEL - FULL HEIGHT	1440 lb
1) JOINT WRAP - 0.065"x6"x50' CONSEAL CS212	0 lb
1) JOINT WRAP PRIMER - CONSEAL CS-75 (1 gal.)	0 lb
1) CASTING - HOE MC-375 F/C BGMU Sanitary	271 lb
2) 48" - Conseal CS-102 1.00" (Double)	0 lb
1) Kor-N-Seal1 - S106-20BW	6 lb
1) Kor-N-Seal2 - S206-22L	6 lb
6) MH Step ML-10-TDS-NCR - 10"	0 lb
Structure Total:	9219 lb

Structure Notes:

1. PER KYTC & ASTM C-478 SPECIFICATIONS
2. CONCRETE: 4,000 PSI AT 28 DAYS
3. REINFORCEMENT: PER ASTM A615
4. INVERT CHANNEL REQUIRED
5. STEPS AT 0 DEGREES
6. HOE MC-375 FRAME & COVER "BGMU SANITARY" SUPPLIED BY ICAST

Rim: 475.66' Rim to Invert: 7.87' Slack: 1.94" Sump: 2.5" Step Position: 0°

Position	Elev	Angle	Ext. (cw)	Pipe	Pipe OD	Connector	Hole	Horz Size	Up (↓)	Offset
Invert 1	467.79'	0°	0"	15" PVC SDR35	15.3"	Kor-N-Seal1 S106-20BW	20"	20.629"	0"	0"
Invert 2	467.89'	90°	45.5"	15" RCP B WALL	19.5"	Kor-N-Seal2 S206-22L	22"	22.854"	0.25"	0"
Invert 3										
Invert 4										
Invert 5										
Invert 6										
Invert 7										
Invert 8										

RIGHT-SIDE UP VIEW (int. dimensions) UPSIDE-DOWN VIEW (int. dimensions)

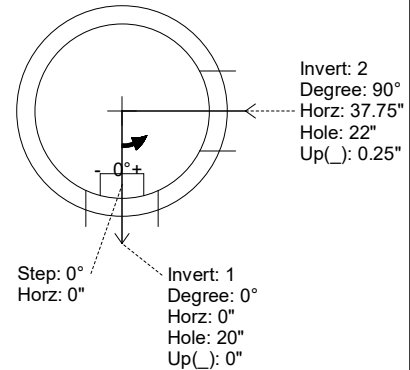
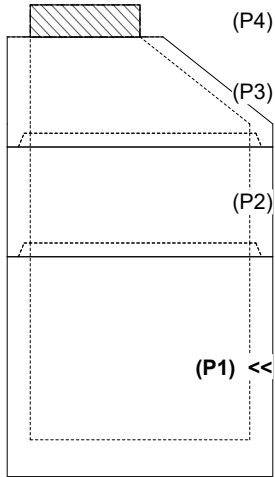

INSIDE WALL DIMENSIONS

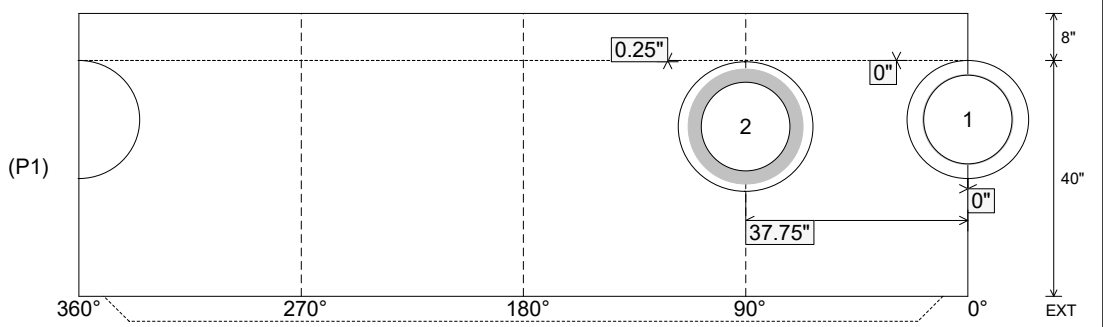

Coating (Int): Coating (Ext):	Seam Up: Tongue Seam Dn: n/a	Wall Thickness: 5" Floor Height: 8"	Height (Int): 40" Height (Ext): 48"	Weight (Net): 4268 lb Volume (Net): 1.09cu.yd
----------------------------------	---------------------------------	--	--	--

Structure ID: 228-77 SS-MH

P1 MH048BAVF

MH BASE (08"F) T/n

P4) 24" - CASTING HEIGHT - 7" P3) 48" - ECC CONE w/ 24" HOLE F/G - 24" P2) 48" - MH RISER T/G - 24" P1) 48" - MH BASE (08"F) T/n - 40" 1) 48" - MH INVERT CHANNEL - FULL HEIGHT 1) JOINT WRAP - 0.065"x6"x50' CONSEAL CS212 1) JOINT WRAP PRIMER - CONSEAL CS-75 (1 gal.) 1) CASTING - HOE MC-375 F/C BGMU Sanitary 2) 48" - Conseal CS-102 1.00" (Double) 1) Kor-N-Seal1 - S106-20BW 1) Kor-N-Seal2 - S206-22L 6) MH Step ML-10-TDS-NCR - 10"	0 lb 1550 lb 1677 lb 4268 lb 1440 lb 0 lb 0 lb 271 lb 0 lb 6 lb 6 lb 0 lb ----- Structure Total: 9219 lb
---	---

Structure Notes:

1. PER KYTC & ASTM C-478 SPECIFICATIONS
2. CONCRETE: 4,000 PSI AT 28 DAYS
3. REINFORCEMENT: PER ASTM A615
4. INVERT CHANNEL REQUIRED
5. STEPS AT 0 DEGREES
6. HOE MC-375 FRAME & COVER "BGMU SANITARY" SUPPLIED BY ICAST

Rim: 475.66' Rim to Invert: 7.87' Slack: 1.94" Sump: 2.5" Step Position: 0°

Position	Elev	Angle	Ext. (cw)	Pipe	Pipe OD	Connector	Hole	Horz Size	Up ()	Offset
Invert 1	467.79'	0°	0"	15" PVC SDR35	15.3"	Kor-N-Seal1 S106-20BW	20"	20.629"	0"	0"
Invert 2	467.89'	90°	45.5"	15" RCP B WALL	19.5"	Kor-N-Seal2 S206-22L	22"	22.854"	0.25"	0"
Invert 3										
Invert 4										
Invert 5										
Invert 6										
Invert 7										
Invert 8										

RIGHT-SIDE UP VIEW (int. dimensions)

UPSIDE-DOWN VIEW (int. dimenions)

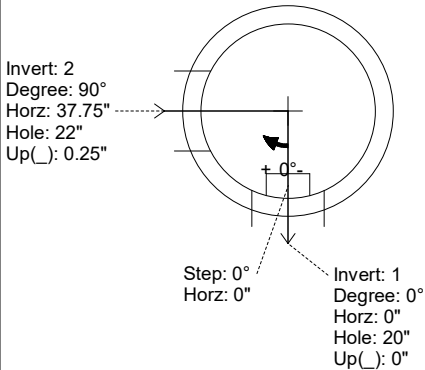
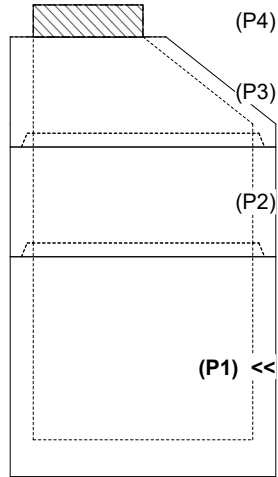

INVERT CHANNEL DRAWING

INSIDE WALL DIMENSIONS

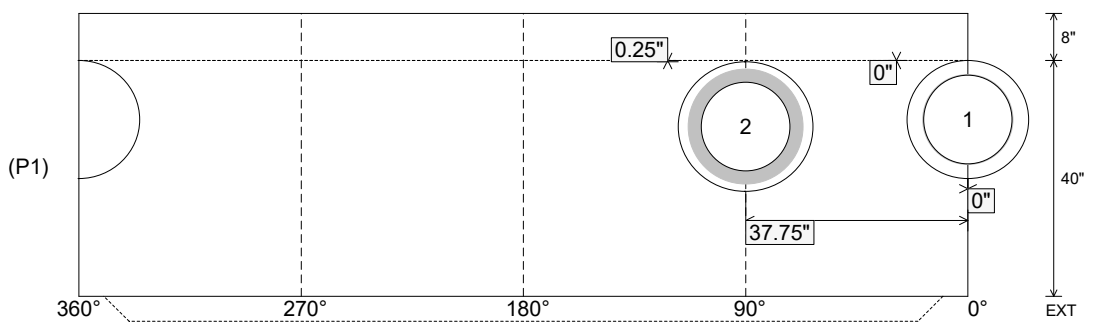

Coating (Int): Coating (Ext):	Seam Up: Tongue Seam Dn: n/a	Wall Thickness: 5" Floor Height: 8"	Height (Int): 40" Height (Ext): 48"	Weight (Net): 4268 lb Volume (Net): 1.09cu.yd
----------------------------------	---------------------------------	--	--	--