

Job Name: 26-1322B - KYTC Warren Co Call 104 (261503)
Job Location: Bowling Green, KY
Contractor: Cumberland Pipeline LLC

PC: Celina Goff
 TECH: Jared - A
 Plant: 100



Structure ID: 227-76 SS-MH

Spec: Sanitary
 Type: SAN.MH
 Size: 48"

Rim: 476.56'
 Invert: 468.07'
 Rim to Invert: 8.49'

Sump: 3.5"
 Floor (Top): 467.778'
 Floor Height: 8"

Floor (Bot): 467.112'
 Overall Height: 9.25'
 Slack: 2.38"

Structure Notes:

1. PER KYTC & ASTM C-478 SPECIFICATIONS
2. CONCRETE: 4,000 PSI AT 28 DAYS
3. REINFORCEMENT: PER ASTM A615
4. INVERT CHANNEL REQUIRED
5. STEPS AT 0 DEGREES
6. HOE MC-375 FRAME & COVER "BGMU SANITARY" SUPPLIED BY ICAST

STRUCTURE SUMMARY:

P4) 24" - CASTING HEIGHT - 7"	0 lb
P3) 48" - ECC CONE w/ 24" HOLE F/G - 24"	1550 lb
P2) 48" - MH RISER T/G - 24"	1677 lb
P1) 48" - MH BASE (08"F) T/n - 48"	4798 lb
1) 48" - MH INVERT CHANNEL - FULL HEIGHT	1440 lb
1) JOINT WRAP - 0.065"x6"x50' CONSEAL CS212	0 lb
1) JOINT WRAP PRIMER - CONSEAL CS-75 (1 gal.)	0 lb
1) CASTING - HOE MC-375 F/C BGMU Sanitary	271 lb
2) 48" - Conseal CS-102 1.00" (Double)	0 lb
2) Kor-N-Seal2 - S206-22L	13 lb
6) MH Step ML-10-TDS-NCR - 10"	0 lb
Structure Total:	9748 lb

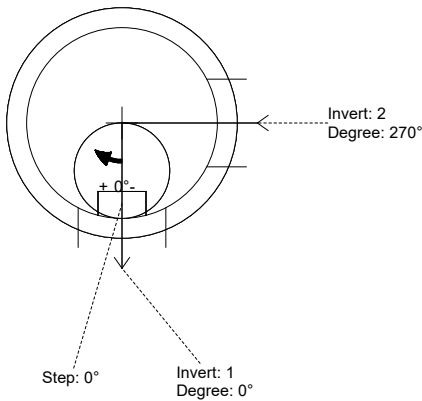

Position	Elev	Angle	Pipe	Pipe OD	Hole	Connector	Up (")	Ref
Rim	476.56'							
Reducer								
Invert 1	468.07'	0°	15" RCP B WALL	19.5"	22"	Kor-N-Seal2 S206-22L	0"	P1
Invert 2	469.55'	270°	15" RCP B WALL	19.5"	22"	Kor-N-Seal2 S206-22L	17.75"	P1
Invert 3								
Invert 4								
Invert 5								
Invert 6								
Invert 7								
Invert 8								

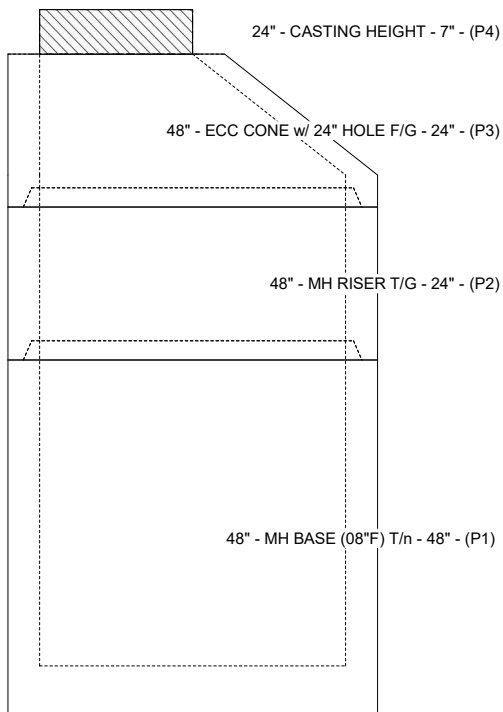

Cast (Int. Dim.) - Interior Dimensions

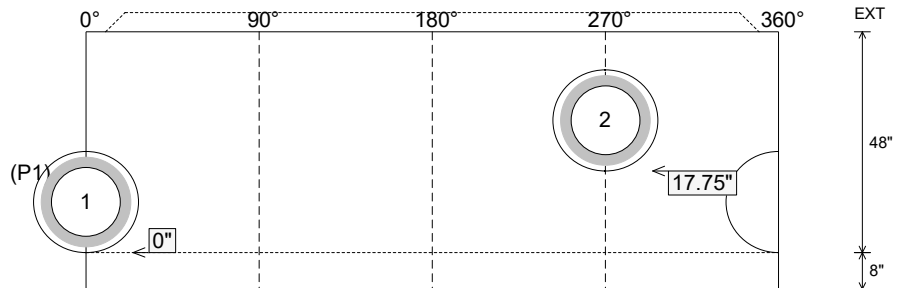

Submittal Drawing
 4/21/2026 12:52:41 PM

SUBMITTAL
 APPROVED BY: