

Job Name: 26-1322B - KYTC Warren Co Call 104 (261503)
 Job Location: Bowling Green, KY
 Contractor: Cumberland Pipeline LLC

Plant: 100

4/21/2026 2:25:10 PM

Tech: Jared - A

PC: Celina Goff

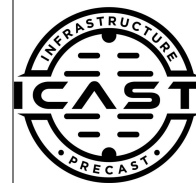

Structure ID: 227-76 SS-MH

P1 MH048BA48

MH BASE (08"F) T/n

- P4) 24" - CASTING HEIGHT - 7"
- P3) 48" - ECC CONE w/ 24" HOLE F/G - 24"
- P2) 48" - MH RISER T/G - 24"
- P1) 48" - MH BASE (08"F) T/n - 48"
- 1) 48" - MH INVERT CHANNEL - FULL HEIGHT
- 1) JOINT WRAP - 0.065"x6"x50' CONSEAL CS212
- 1) JOINT WRAP PRIMER - CONSEAL CS-75 (1 gal.)
- 1) CASTING - HOE MC-375 F/C BGMU Sanitary
- 2) 48" - Conseal CS-102 1.00" (Double)
- 2) Kor-N-Seal2 - S206-22L
- 6) MH Step ML-10-TDS-NCR - 10"

0 lb
 1550 lb
 1677 lb
 4798 lb
 1440 lb
 0 lb
 0 lb
 271 lb
 0 lb
 13 lb
 0 lb

 Structure Total: 9748 lb

- Structure Notes:**
1. PER KYTC & ASTM C-478 SPECIFICATIONS
 2. CONCRETE: 4,000 PSI AT 28 DAYS
 3. REINFORCEMENT: PER ASTM A615
 4. INVERT CHANNEL REQUIRED
 5. STEPS AT 0 DEGREES
 6. HOE MC-375 FRAME & COVER "BGMU SANITARY" SUPPLIED BY ICAST

Rim: 476.56' Rim to Invert: 8.49' Slack: 2.38' Sump: 3.5' Step Position: 0

Position	Elev	Angle	Ext. (cw)	Pipe	Pipe OD	Connector	Hole	Horz Size	Up ()	Offset
Invert 1	468.07'	0°	0"	15" RCP B WALL	19.5"	Kor-N-Seal2 S206-22L	22"	22.854"	0"	0"
Invert 2	469.55'	270°	136.625"	15" RCP B WALL	19.5"	Kor-N-Seal2 S206-22L	22"	22.854"	17.75"	0"
Invert 3										
Invert 4										
Invert 5										
Invert 6										
Invert 7										
Invert 8										

RIGHT-SIDE UP VIEW (int. dimensions)

UPSIDE-DOWN VIEW (int. dimensions)

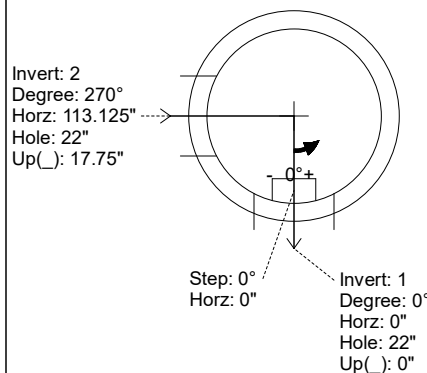
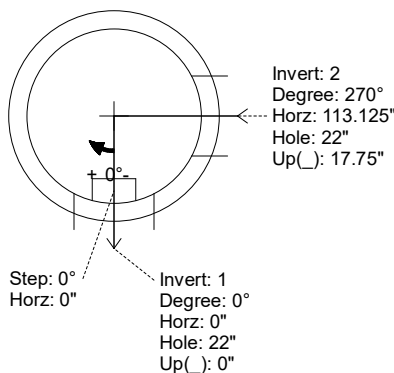
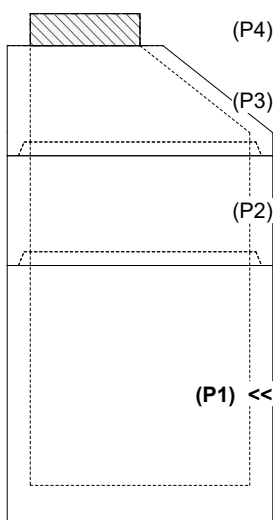

INSIDE WALL DIMENSIONS

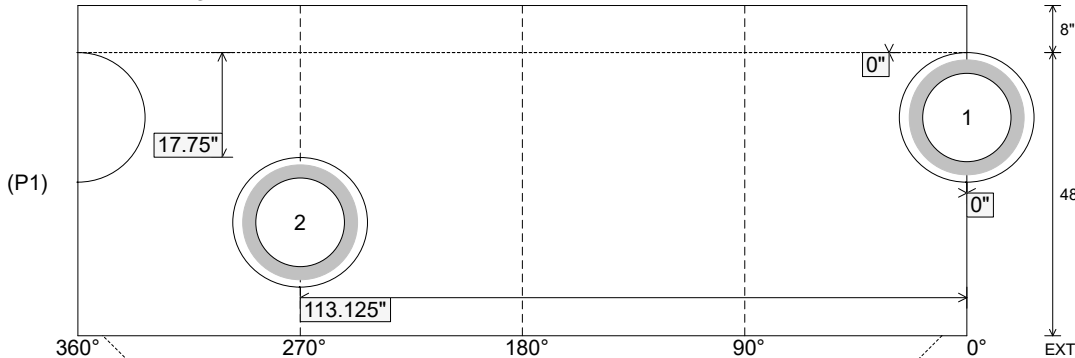

Coating (Int):
 Coating (Ext):

Seam Up: Tongue
 Seam Dn: n/a

Wall Thickness: 5"
 Floor Height: 8"

Height (Int): 48"
 Height (Ext): 56"

Weight (Net): 4798 lb
 Volume (Net): 1.23cu.yd

Job Name: 26-1322B - KYTC Warren Co Call 104 (261503)
 Job Location: Bowling Green, KY
 Contractor: Cumberland Pipeline LLC

Plant: 100

4/21/2026 2:25:10 PM

Tech: Jared - A

PC: Celina Goff



Structure ID: 227-76 SS-MH

P1 MH048BA48

MH BASE (08"F) T/n

- P4) 24" - CASTING HEIGHT - 7"
- P3) 48" - ECC CONE w/ 24" HOLE F/G - 24"
- P2) 48" - MH RISER T/G - 24"
- P1) 48" - MH BASE (08"F) T/n - 48"
- 1) 48" - MH INVERT CHANNEL - FULL HEIGHT
- 1) JOINT WRAP - 0.065"x6"x50' CONSEAL CS212
- 1) JOINT WRAP PRIMER - CONSEAL CS-75 (1 gal.)
- 1) CASTING - HOE MC-375 F/C BGMU Sanitary
- 2) 48" - Conseal CS-102 1.00" (Double)
- 2) Kor-N-Seal2 - S206-22L
- 6) MH Step ML-10-TDS-NCR - 10"

0 lb
 1550 lb
 1677 lb
 4798 lb
 1440 lb
 0 lb
 0 lb
 271 lb
 0 lb
 13 lb
 0 lb

Structure Total: 9748 lb

Structure Notes:

1. PER KYTC & ASTM C-478 SPECIFICATIONS
2. CONCRETE: 4,000 PSI AT 28 DAYS
3. REINFORCEMENT: PER ASTM A615
4. INVERT CHANNEL REQUIRED
5. STEPS AT 0 DEGREES
6. HOE MC-375 FRAME & COVER "BGMU SANITARY" SUPPLIED BY ICAST

Rim: 476.56' Rim to Invert: 8.49' Slack: 2.38' Sump: 3.5' Step Position: 0

Position	Elev	Angle	Ext. (cw)	Pipe	Pipe OD	Connector	Hole	Horz Size	Up ()	Offset
Invert 1	468.07'	0°	0"	15" RCP B WALL	19.5"	Kor-N-Seal2 S206-22L	22"	22.854"	0"	0"
Invert 2	469.55'	270°	136.625"	15" RCP B WALL	19.5"	Kor-N-Seal2 S206-22L	22"	22.854"	17.75"	0"
Invert 3										
Invert 4										
Invert 5										
Invert 6										
Invert 7										
Invert 8										

RIGHT-SIDE UP VIEW (int. dimensions)

UPSIDE-DOWN VIEW (int. dimenions)

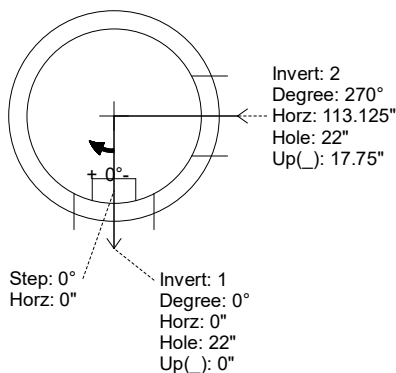
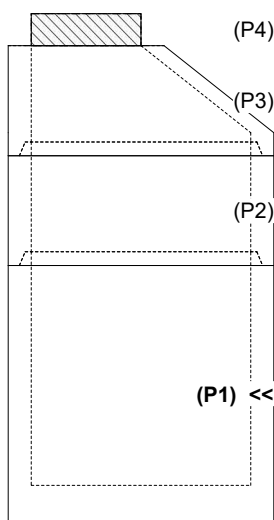

INVERT CHANNEL DRAWING

INSIDE WALL DIMENSIONS

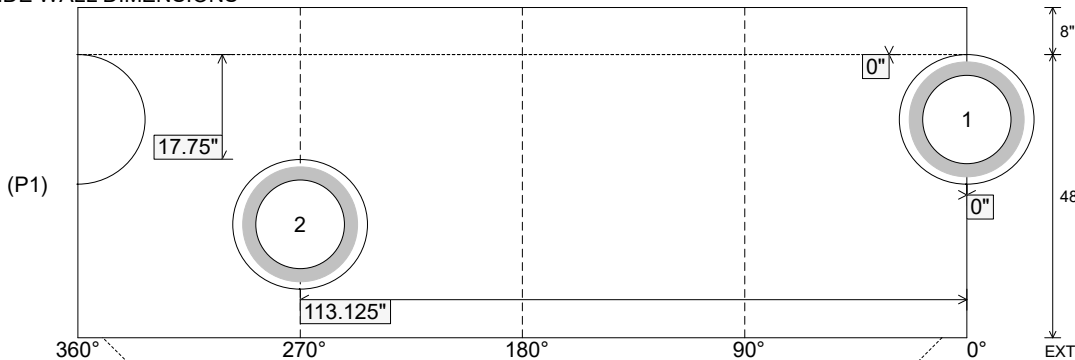

Coating (Int):
 Coating (Ext):

Seam Up: Tongue
 Seam Dn: n/a

Wall Thickness: 5"
 Floor Height: 8"

Height (Int): 48"
 Height (Ext): 56"

Weight (Net): 4798 lb
 Volume (Net): 1.23cu.yd