

Job Name: 26-1322B - KYTC Warren Co Call 104 (261503)  
 Job Location: Bowling Green, KY  
 Contractor: Cumberland Pipeline LLC

Plant: 100

Tech: Jared - A

4/21/2026 3:37:21 PM

PC: Celina Goff



**Structure ID: 223-75 SS-MH**

**P3 MH048CN24**

**ECC CONE w/ 24" HOLE F/G**

- P4) 24" - CASTING HEIGHT - 7"
- P3) 48" - ECC CONE w/ 24" HOLE F/G - 24"
- P2) 48" - MH RISER SPECIAL T/G - 36"
- P1) 48" - MH BASE (08"F) T/n - 30"
- 1) 48" - MH INVERT CHANNEL - FULL HEIGHT
- 1) JOINT WRAP - 0.065"x6"x50' CONSEAL CS212
- 1) JOINT WRAP PRIMER - CONSEAL CS-75 (1 gal.)
- 1) CASTING - HOE MC-375 F/C BGMU Sanitary
- 2) 48" - Conseal CS-102 1.00" (Double)
- 1) Kor-N-Seal2 - S206-22L
- 1) Kor-N-Seal1 - S106-20BW
- 6) MH Step ML-10-TDS-NCR - 10"

0 lb  
 1550 lb  
 2380 lb  
 3705 lb  
 1440 lb  
 0 lb  
 0 lb  
 271 lb  
 0 lb  
 6 lb  
 6 lb  
 0 lb  
 -----  
 Structure Total: 9358 lb

Structure Notes:  
 1. PER KYTC & ASTM C-478 SPECIFICATIONS  
 2. CONCRETE: 4,000 PSI AT 28 DAYS  
 3. REINFORCEMENT: PER ASTM A615  
 4. STEPS REQUIRED  
 5. HOE MC-375 FRAME & COVER "BGMU SANITARY" SUPPLIED BY ICAST

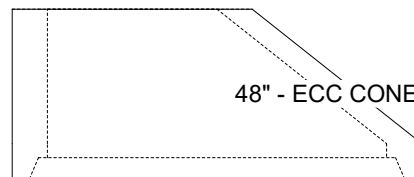
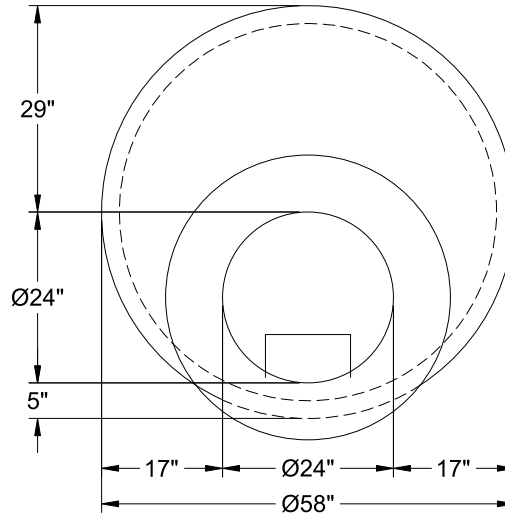

48" - ECC CONE w/ 24" HOLE F/G - 24" - (P3)

Coating (Int):  
 Coating (Ext):

Seam Up: Flat  
 Seam Dn: Groove

Wall Thickness: 5"

Height (Ext): 24"

Weight (Net): 1550 lb  
 Volume (Net): 0.33cu.yd