

Structure ID: 180-85 SS-MH

P1 MH048BAVF

MH BASE (08"F) T/n

P4) 24" - CASTING HEIGHT - 7" P3) 48" - ECC CONE w/ 24" HOLE F/G - 36" P2) 48" - MH RISER T/G - 24" P1) 48" - MH BASE (08"F) T/n - 34" 1) 48" - MH INVERT CHANNEL - FULL HEIGHT 1) JOINT WRAP - 0.065"x6"x50' CONSEAL CS212 1) JOINT WRAP PRIMER - CONSEAL CS-75 (1 gal.) 1) CASTING - HOE MC-375 F/C BGMU Sanitary 2) 48" - Conseal CS-102 1.00" (Double) 2) Kor-N-Seal2 - S206-28 6) MH Step ML-10-TDS-NCR - 10"	<table style="width:100%; border-collapse: collapse;"> <tr><td style="text-align: right;">0 lb</td><td></td></tr> <tr><td style="text-align: right;">3000 lb</td><td></td></tr> <tr><td style="text-align: right;">1677 lb</td><td></td></tr> <tr><td style="text-align: right;">3603 lb</td><td></td></tr> <tr><td style="text-align: right;">1440 lb</td><td></td></tr> <tr><td style="text-align: right;">0 lb</td><td></td></tr> <tr><td style="text-align: right;">0 lb</td><td></td></tr> <tr><td style="text-align: right;">271 lb</td><td></td></tr> <tr><td style="text-align: right;">0 lb</td><td></td></tr> <tr><td style="text-align: right;">13 lb</td><td></td></tr> <tr><td style="text-align: right;">0 lb</td><td></td></tr> <tr><td style="text-align: right;">-----</td><td></td></tr> <tr><td style="text-align: right;">Structure Total:</td><td style="text-align: right;">10004 lb</td></tr> </table>	0 lb		3000 lb		1677 lb		3603 lb		1440 lb		0 lb		0 lb		271 lb		0 lb		13 lb		0 lb		-----		Structure Total:	10004 lb
0 lb																											
3000 lb																											
1677 lb																											
3603 lb																											
1440 lb																											
0 lb																											
0 lb																											
271 lb																											
0 lb																											
13 lb																											
0 lb																											

Structure Total:	10004 lb																										

Structure Notes:

1. PER KYTC & ASTM C-478 SPECIFICATIONS
2. CONCRETE: 4,000 PSI AT 28 DAYS
3. REINFORCEMENT: PER ASTM A615
4. INVERT CHANNEL REQUIRED
5. STEPS AT 0 DEGREES
6. HOE MC-375 FRAME & COVER "BGMU SANITARY" SUPPLIED BY ICAST

Rim: 477.69' Rim to Invert: 8.35' Slack: 1.2" Sump: 2" Step Position: 0

Position	Elev	Angle	Ext. (cw)	Pipe	Pipe OD	Connector	Hole	Horz Size	Up (↓)	Offset
Invert 1	469.34'	0°	0"	24" PVC SDR35	24.75"	Kor-N-Seal2 S206-28	28"	29.896"	0"	0"
Invert 2	469.44'	178°	90.125"	24" PVC SDR35	24.75"	Kor-N-Seal2 S206-28	28"	29.896"	1.25"	0"
Invert 3										
Invert 4										
Invert 5										
Invert 6										
Invert 7										
Invert 8										

RIGHT-SIDE UP VIEW (int. dimensions)

UPSIDE-DOWN VIEW (int. dimensions)

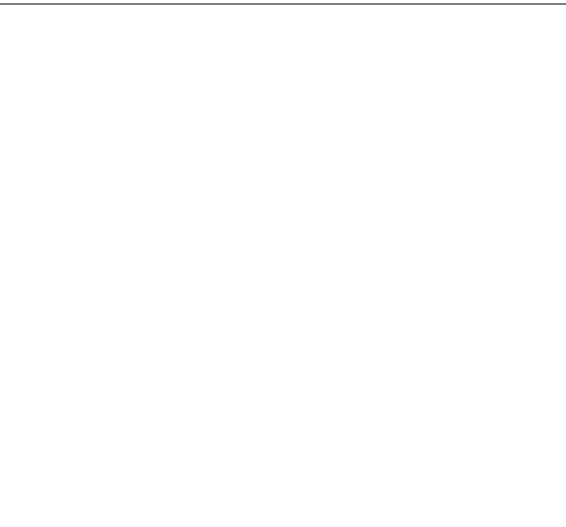
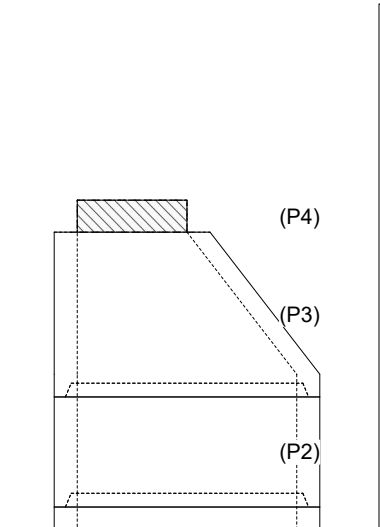

INSIDE WALL DIMENSIONS

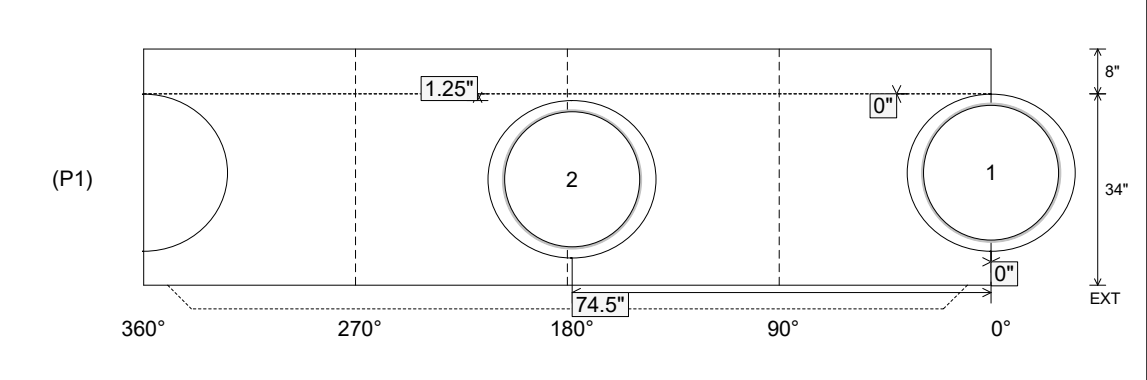

Coating (Int): Coating (Ext):	Seam Up: Tongue Seam Dn: n/a	Wall Thickness: 5" Floor Height: 8"	Height (Int): 34" Height (Ext): 42"	Weight (Net): 3603 lb Volume (Net): 0.92cu.yd
----------------------------------	---------------------------------	--	--	--

Job Name: 26-1322B - KYTC Warren Co Call 104 (261503)
 Job Location: Bowling Green, KY
 Contractor: Cumberland Pipeline LLC

Plant: 100

4/21/2026 2:25:14 PM

Tech: Jared - A

PC: Celina Goff



Structure ID: 180-85 SS-MH

P1 MH048BAVF

MH BASE (08"F) T/n

- P4) 24" - CASTING HEIGHT - 7"
- P3) 48" - ECC CONE w/ 24" HOLE F/G - 36"
- P2) 48" - MH RISER T/G - 24"
- P1) 48" - MH BASE (08"F) T/n - 34"
- 1) 48" - MH INVERT CHANNEL - FULL HEIGHT
- 1) JOINT WRAP - 0.065"x6"x50' CONSEAL CS212
- 1) JOINT WRAP PRIMER - CONSEAL CS-75 (1 gal.)
- 1) CASTING - HOE MC-375 F/C BGMU Sanitary
- 2) 48" - Conseal CS-102 1.00" (Double)
- 2) Kor-N-Seal2 - S206-28
- 6) MH Step ML-10-TDS-NCR - 10"

0 lb
 3000 lb
 1677 lb
 3603 lb
 1440 lb
 0 lb
 0 lb
 271 lb
 0 lb
 13 lb
 0 lb

 Structure Total: 10004 lb

- Structure Notes:**
1. PER KYTC & ASTM C-478 SPECIFICATIONS
 2. CONCRETE: 4,000 PSI AT 28 DAYS
 3. REINFORCEMENT: PER ASTM A615
 4. INVERT CHANNEL REQUIRED
 5. STEPS AT 0 DEGREES
 6. HOE MC-375 FRAME & COVER "BGMU SANITARY" SUPPLIED BY ICAST

Rim: 477.69' Rim to Invert: 8.35' Slack: 1.2" Sump: 2" Step Position: 0

Position	Elev	Angle	Ext. (cw)	Pipe	Pipe OD	Connector	Hole	Horz Size	Up ()	Offset
Invert 1	469.34'	0°	0"	24" PVC SDR35	24.75"	Kor-N-Seal2 S206-28	28"	29.896"	0"	0"
Invert 2	469.44'	178°	90.125"	24" PVC SDR35	24.75"	Kor-N-Seal2 S206-28	28"	29.896"	1.25"	0"
Invert 3										
Invert 4										
Invert 5										
Invert 6										
Invert 7										
Invert 8										

RIGHT-SIDE UP VIEW (int. dimensions)

UPSIDE-DOWN VIEW (int. dimenions)

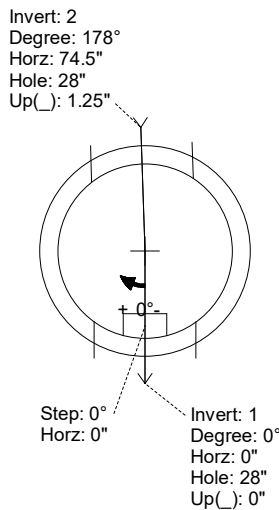
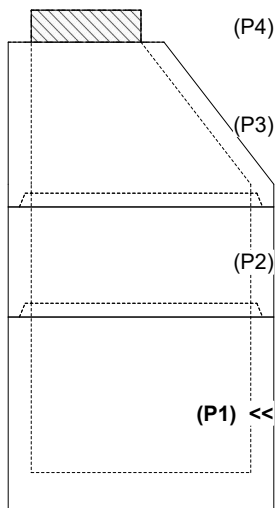

INVERT CHANNEL DRAWING

INSIDE WALL DIMENSIONS

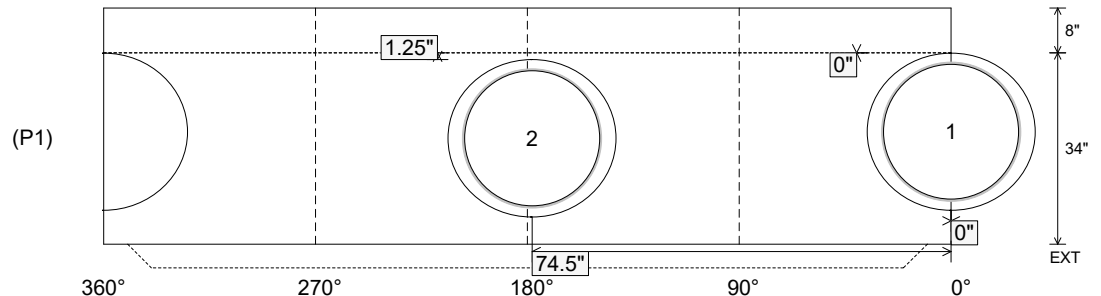

Coating (Int):
 Coating (Ext):

Seam Up: Tongue
 Seam Dn: n/a

Wall Thickness: 5"
 Floor Height: 8"

Height (Int): 34"
 Height (Ext): 42"

Weight (Net): 3603 lb
 Volume (Net): 0.92cu.yd