

Job Name: 26-1322B - KYTC Warren Co Call 104 (261503)
 Job Location: Bowling Green, KY
 Contractor: Cumberland Pipeline LLC

Plant: 100

Tech: Jared - A

4/21/2026 3:37:23 PM

PC: Celina Goff



Structure ID: 179-84 SS-MH

P3 MH048CN30

ECC CONE w/ 24" HOLE F/G

- P4) 24" - CASTING HEIGHT - 7"
- P3) 48" - ECC CONE w/ 24" HOLE F/G - 30"
- P2) 48" - MH RISER SPECIAL T/G - 24"
- P1) 48" - MH BASE (08"F) T/n - 34"
- 1) 48" - MH INVERT CHANNEL - FULL HEIGHT
- 1) JOINT WRAP - 0.065"x6"x50' CONSEAL CS212
- 1) JOINT WRAP PRIMER - CONSEAL CS-75 (1 gal.)
- 1) CASTING - HOE MC-375 F/C BGMU Sanitary
- 2) 48" - Conseal CS-102 1.00" (Double)
- 2) Kor-N-Seal2 - S206-28
- 1) PSX - 12-06 NYLO
- 1) PSX - 12-08 NYLO
- 6) MH Step ML-10-TDS-NCR - 10"

- 0 lb
- 2050 lb
- 1629 lb
- 3555 lb
- 1440 lb
- 0 lb
- 0 lb
- 271 lb
- 0 lb
- 13 lb
- 8 lb
- 8 lb
- 0 lb

Structure Notes:
 1. PER KYTC & ASTM C-478 SPECIFICATIONS
 2. CONCRETE: 4,000 PSI AT 28 DAYS
 3. REINFORCEMENT: PER ASTM A615
 4. STEPS REQUIRED
 5. HOE MC-375 FRAME & COVER "BGMU SANITARY" SUPPLIED BY ICAST

Structure Total: 8974 lb

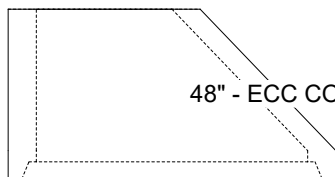
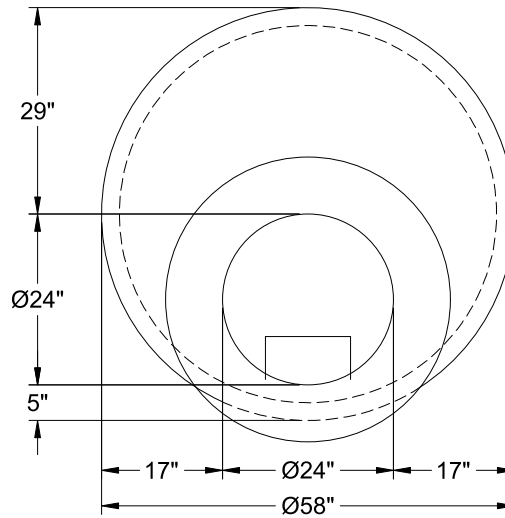

48" - ECC CONE w/ 24" HOLE F/G - 30" - (P3)

Coating (Int):
 Coating (Ext):

Seam Up: Flat
 Seam Dn: Groove

Wall Thickness: 5"

Height (Ext): 30"

Weight (Net): 2050 lb
 Volume (Net): 0.41cu.yd