

Job Name: 26-1322B - KYTC Warren Co Call 104 (261503)
Job Location: Bowling Green, KY
Contractor: Cumberland Pipeline LLC

PC: Celina Goff
 TECH: Jared - A
 Plant: 100



Structure ID: 178-83 SS-MH

Spec: Sanitary
 Type: SAN.MH
 Size: 48"

Rim: 475.96'
 Invert: 468.78'
 Rim to Invert: 7.18'

Sump: 2"
 Floor (Top): 468.613'
 Floor Height: 8"

Floor (Bot): 467.947'
 Overall Height: 7.917'
 Slack: 1.16"

Structure Notes:

1. PER KYTC & ASTM C-478 SPECIFICATIONS
2. CONCRETE: 4,000 PSI AT 28 DAYS
3. REINFORCEMENT: PER ASTM A615
4. INVERT CHANNEL REQUIRED
5. STEPS AT 0 DEGREES
6. HOE MC-375 FRAME & COVER "BGMU SANITARY" SUPPLIED BY ICAST

STRUCTURE SUMMARY:

P3) 24" - CASTING HEIGHT - 7"	0 lb
P2) 48" - ECC CONE w/ 24" HOLE F/G - 36"	3000 lb
P1) 48" - MH BASE (08"F) T/n - 44"	4302 lb
1) 48" - MH INVERT CHANNEL - FULL HEIGHT	1440 lb
1) JOINT WRAP - 0.065"x6"x50' CONSEAL CS212	0 lb
1) JOINT WRAP PRIMER - CONSEAL CS-75 (1 gal.)	0 lb
1) CASTING - HOE MC-375 F/C BGMU Sanitary	271 lb
1) 48" - Conseal CS-102 1.00" (Double)	0 lb
2) Kor-N-Seal2 - S206-28	13 lb
5) MH Step ML-10-TDS-NCR - 10"	0 lb
Structure Total:	9026 lb

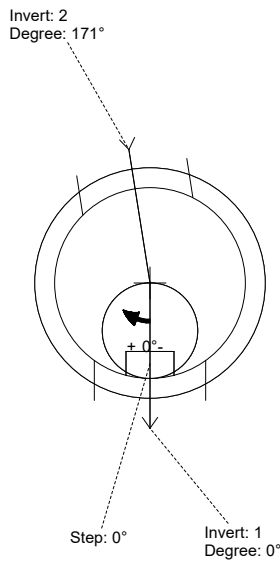

Position	Elev	Angle	Pipe	Pipe OD	Hole	Connector	Up (")	Ref
Rim	475.96'							
Reducer								
Invert 1	468.78'	0°	24" PVC SDR35	24.75"	28"	Kor-N-Seal2 S206-28	0"	P1
Invert 2	468.88'	171°	24" PVC SDR35	24.75"	28"	Kor-N-Seal2 S206-28	1.25"	P1
Invert 3								
Invert 4								
Invert 5								
Invert 6								
Invert 7								
Invert 8								

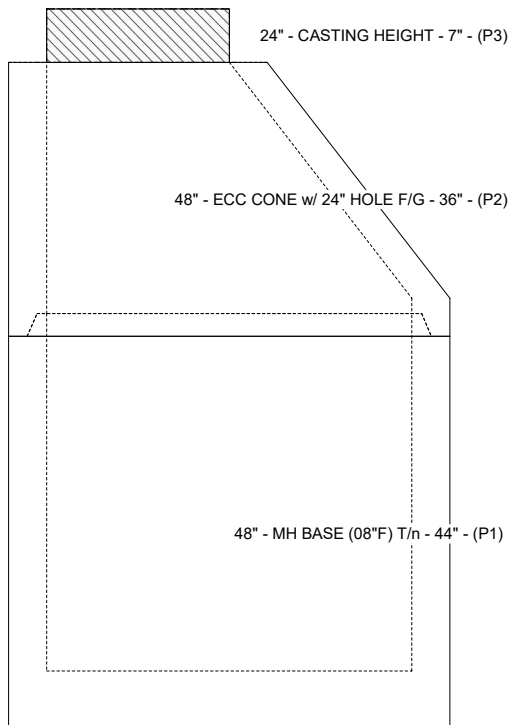

Cast (Int. Dim.) - Interior Dimensions

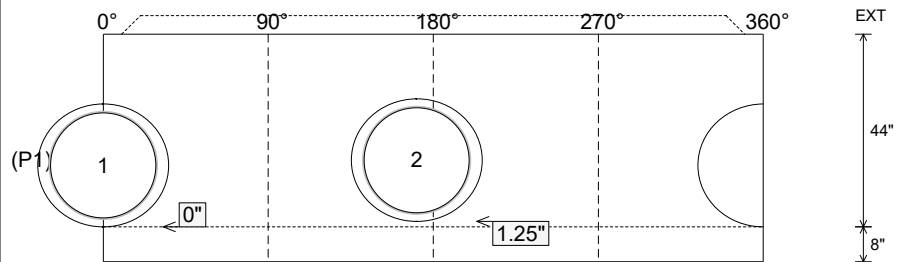

Submittal Drawing
 4/21/2026 12:52:44 PM

SUBMITTAL
 APPROVED BY: