

Structure ID: 154-91 SS-MH

P1 MH048BAVF

MH BASE (08"F) T/n

P4) 24" - CASTING HEIGHT - 7" P3) 48" - ECC CONE w/ 24" HOLE F/G - 36" P2) 48" - MH RISER T/G - 36" P1) 48" - MH BASE (08"F) T/n - 38" 1) 48" - MH INVERT CHANNEL - FULL HEIGHT 1) JOINT WRAP - 0.065"x6"x50' CONSEAL CS212 1) JOINT WRAP PRIMER - CONSEAL CS-75 (1 gal.) 1) CASTING - HOE MC-375 F/C BGMU Sanitary 2) 48" - Conseal CS-102 1.00" (Double) 2) PSX - 16L NYLO 8) MH Step ML-10-TDS-NCR - 10"	<table style="width:100%; border-collapse: collapse;"> <tr><td>0 lb</td></tr> <tr><td>3000 lb</td></tr> <tr><td>2515 lb</td></tr> <tr><td>4257 lb</td></tr> <tr><td>1440 lb</td></tr> <tr><td>0 lb</td></tr> <tr><td>0 lb</td></tr> <tr><td>271 lb</td></tr> <tr><td>0 lb</td></tr> <tr><td>16 lb</td></tr> <tr><td>0 lb</td></tr> <tr><td>-----</td></tr> <tr><td>Structure Total: 11499 lb</td></tr> </table>	0 lb	3000 lb	2515 lb	4257 lb	1440 lb	0 lb	0 lb	271 lb	0 lb	16 lb	0 lb	-----	Structure Total: 11499 lb
0 lb														
3000 lb														
2515 lb														
4257 lb														
1440 lb														
0 lb														
0 lb														
271 lb														
0 lb														
16 lb														
0 lb														

Structure Total: 11499 lb														

Structure Notes:

1. PER KYTC & ASTM C-478 SPECIFICATIONS
2. CONCRETE: 4,000 PSI AT 28 DAYS
3. REINFORCEMENT: PER ASTM A615
4. INVERT CHANNEL REQUIRED
5. STEPS AT 0 DEGREES
6. HOE MC-375 FRAME & COVER "BGMU SANITARY" SUPPLIED BY ICAST

Rim: 533.54' Rim to Invert: 9.71' Slack: 1.52" Sump: 2" Step Position: 0

Position	Elev	Angle	Ext. (cw)	Pipe	Pipe OD	Connector	Hole	Horz Size	Up ()	Offset
Invert 1	523.83'	0°	0"	12" PVC SDR35	12.5"	PSX 16L NYLO	16"	16.312"	0"	0"
Invert 2	524.03'	121°	61.25"	12" PVC SDR35	12.5"	PSX 16L NYLO	16"	16.312"	2.375"	0"
Invert 3										
Invert 4										
Invert 5										
Invert 6										
Invert 7										
Invert 8										

RIGHT-SIDE UP VIEW (int. dimensions)

UPSIDE-DOWN VIEW (int. dimensions)

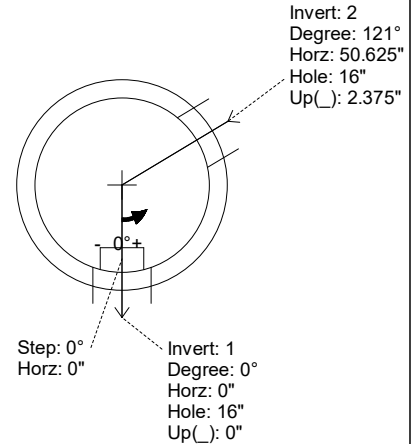
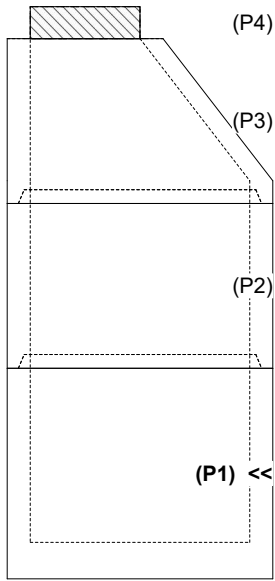

INSIDE WALL DIMENSIONS

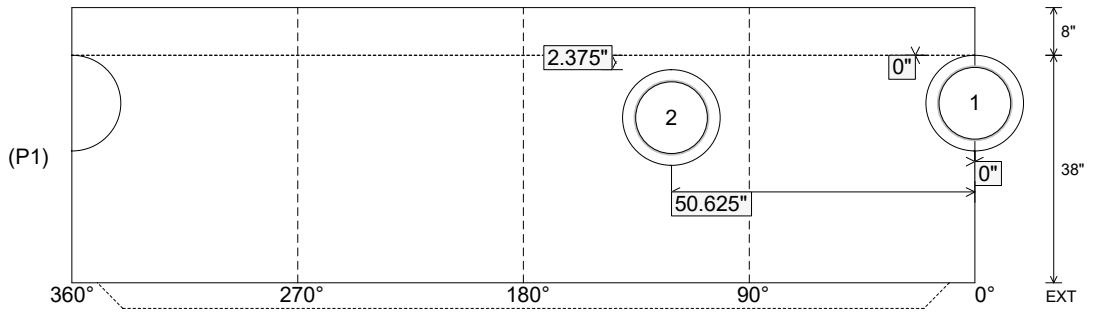

Coating (Int): Coating (Ext):	Seam Up: Tongue Seam Dn: n/a	Wall Thickness: 5" Floor Height: 8"	Height (Int): 38" Height (Ext): 46"	Weight (Net): 4257 lb Volume (Net): 1.09cu.yd
----------------------------------	---------------------------------	--	--	--

Structure ID: 154-91 SS-MH

P1 MH048BAVF

MH BASE (08"F) T/n

P4) 24" - CASTING HEIGHT - 7" P3) 48" - ECC CONE w/ 24" HOLE F/G - 36" P2) 48" - MH RISER T/G - 36" P1) 48" - MH BASE (08"F) T/n - 38" 1) 48" - MH INVERT CHANNEL - FULL HEIGHT 1) JOINT WRAP - 0.065"x6"x50' CONSEAL CS212 1) JOINT WRAP PRIMER - CONSEAL CS-75 (1 gal.) 1) CASTING - HOE MC-375 F/C BGMU Sanitary 2) 48" - Conseal CS-102 1.00" (Double) 2) PSX - 16L NYLO 8) MH Step ML-10-TDS-NCR - 10"	<table style="width:100%; border-collapse: collapse;"> <tr><td>0 lb</td></tr> <tr><td>3000 lb</td></tr> <tr><td>2515 lb</td></tr> <tr><td>4257 lb</td></tr> <tr><td>1440 lb</td></tr> <tr><td>0 lb</td></tr> <tr><td>0 lb</td></tr> <tr><td>271 lb</td></tr> <tr><td>0 lb</td></tr> <tr><td>16 lb</td></tr> <tr><td>0 lb</td></tr> <tr><td style="border-top: 1px solid black;">-----</td></tr> <tr><td>Structure Total: 11499 lb</td></tr> </table>	0 lb	3000 lb	2515 lb	4257 lb	1440 lb	0 lb	0 lb	271 lb	0 lb	16 lb	0 lb	-----	Structure Total: 11499 lb
0 lb														
3000 lb														
2515 lb														
4257 lb														
1440 lb														
0 lb														
0 lb														
271 lb														
0 lb														
16 lb														
0 lb														

Structure Total: 11499 lb														

Structure Notes:

1. PER KYTC & ASTM C-478 SPECIFICATIONS
2. CONCRETE: 4,000 PSI AT 28 DAYS
3. REINFORCEMENT: PER ASTM A615
4. INVERT CHANNEL REQUIRED
5. STEPS AT 0 DEGREES
6. HOE MC-375 FRAME & COVER "BGMU SANITARY" SUPPLIED BY ICAST

Rim: 533.54' Rim to Invert: 9.71' Slack: 1.52" Sump: 2" Step Position: 0

Position	Elev	Angle	Ext. (cw)	Pipe	Pipe OD	Connector	Hole	Horz Size	Up ()	Offset
Invert 1	523.83'	0°	0"	12" PVC SDR35	12.5"	PSX 16L NYLO	16"	16.312"	0"	0"
Invert 2	524.03'	121°	61.25"	12" PVC SDR35	12.5"	PSX 16L NYLO	16"	16.312"	2.375"	0"
Invert 3										
Invert 4										
Invert 5										
Invert 6										
Invert 7										
Invert 8										

RIGHT-SIDE UP VIEW (int. dimensions)

UPSIDE-DOWN VIEW (int. dimensions)

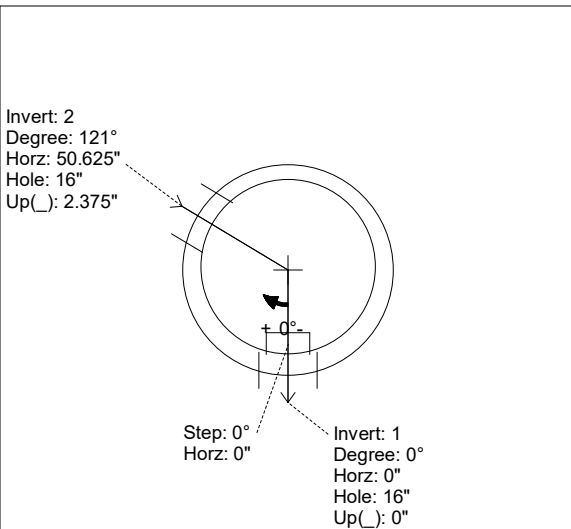
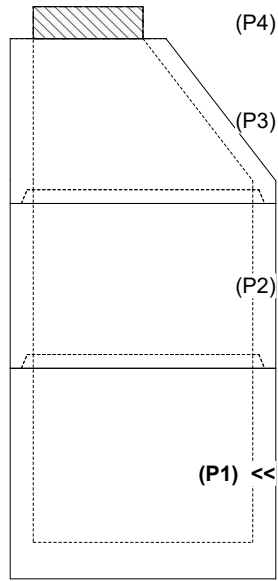

INVERT CHANNEL DRAWING

INSIDE WALL DIMENSIONS

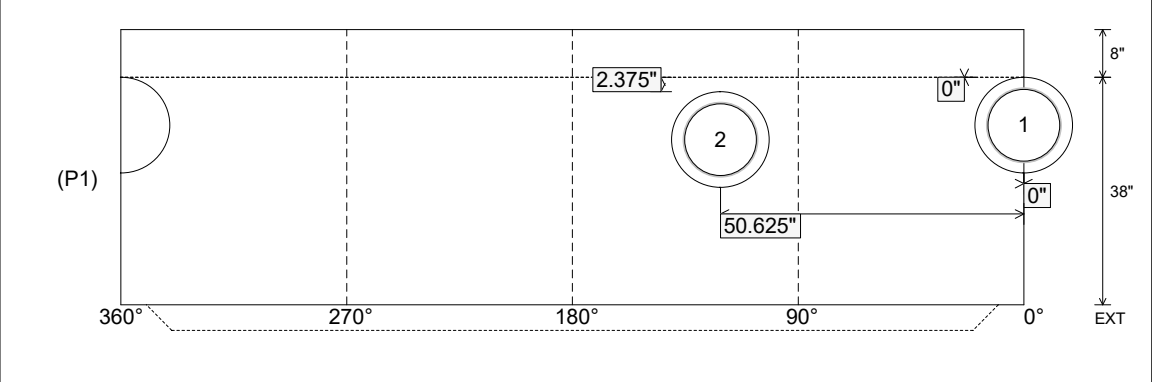

Coating (Int): Coating (Ext):	Seam Up: Tongue Seam Dn: n/a	Wall Thickness: 5" Floor Height: 8"	Height (Int): 38" Height (Ext): 46"	Weight (Net): 4257 lb Volume (Net): 1.09cu.yd
----------------------------------	---------------------------------	--	--	--